



**MEETING OF THE MAYOR AND BOARD OF ALDERMEN
SOUTHAVEN, MISSISSIPPI
CITY HALL
January 3, 2023
6:00 PM
AGENDA**

- 1. Call To Order**
- 2. Invocation**
- 3. Pledge Of Allegiance**
- 4. Approval of Minutes: December 20, 2022**
- 5. Approval of Travel for MML and DC Congressional Briefing Trip**
- 6. Approval of Contract for Printer with RJ Young Company**
- 7. Resolution for City Utilities Rates**
- 8. Planning Agenda**
- 9. Mayor's Report**
- 10. Personnel Docket**
- 11. City Attorney's Legal Update**
- 12. Utilities Billing Leak Adjustment Docket**
- 13. Claims Docket**
- 14. Executive Session: Claims/Litigation involving the City; Economic Development; Interdepartmental Personnel with No Action**

Items may be added to or omitted from this agenda as needed.

Minutes, City of Southaven, Southaven, Mississippi



**MEETING OF THE MAYOR AND BOARD OF ALDERMEN
SOUTHAVEN, MISSISSIPPI
CITY HALL
December 20, 2022
6:00 PM
AGENDA**

1. Call To Order
2. Invocation
3. Pledge Of Allegiance
4. Approval of Minutes: December 6, 2022 & Special Meeting December 8, 2022
5. Donation Docket
6. Dizzy Dean Contract
7. Contract with P.B.J. Happee Day Shows, Inc.
8. Resolution for Ratification for Utilities Emergency Expenditure
9. Contract with Event Concessions
10. SFD Contracts with Mississippi Ambulance Alliance
11. SFD Licensing Agreement
12. FY 22 Audit Engagement Letter with Watkins, Ward, and Stafford, PLLC
13. Resolution for Budget Amendment
14. Contract with Argo Entertainment, LLC
15. Approval of City Depository
16. Resolution for SFD Surplus
17. Resolution to Clean Private Property
18. Planning Agenda: Item #1 Application by West Realty Partnership, LP to revise the PUD uses and design for 113.3 acres of property on the south side of Church Road, both sides of Airways Blvd.
Item #2 Application by SMJ Enterprise, LLC to revise the PUD design for 144 acres on the north side of Nail Road, west of Getwell Road
19. Mayor's Report
20. Personnel Docket
21. City Attorney's Legal Update
22. Utilities Billing Leak Adjustment Docket
23. Claims Dockets: Docket 1
Docket 2
24. Executive Session: Ongoing and Potential Litigation Involving the City; Economic Development; Interdepartmental Personnel with No Action

Items may be added to or omitted from this agenda as needed.

THIS PAGE WAS LEFT BLANK INTENTIONALLY

Minutes, City of Southaven, Southaven, Mississippi

**MINUTES OF THE REGULAR MEETING
OF DECEMBER 20, 2022
OF THE MAYOR AND BOARD OF ALDERMEN
OF THE CITY OF SOUTHAVEN, MISSISSIPPI**

BE IT REMEMBERED that the Mayor and Board of Aldermen of the City of Southaven, Mississippi met in a Regular Meeting on the 20th day of December, 2022 at six o'clock (6:00) p.m. at City Hall.

Present were:

George Payne	Alderman At Large
Kristian Kelly	Alderman, Ward 1
Charlie Hoots	Alderman, Ward 2
William Jerome	Alderman, Ward 3
Joel Gallagher	Alderman, Ward 4
John David Wheeler	Alderman, Ward 5
Raymond Flores	Alderman, Ward 6

Also present were Mayor Musselwhite, Andrea Mullen, City Clerk, and Nick Manley, City Attorney. Approximately thirty (30) other people were present. Mayor Musselwhite called the meeting to order. Alderman Gallagher led in prayer followed by the Pledge of Allegiance led by Alderman Payne.

Next, a motion was made by Alderman Hoots to approve the minutes of the Regular Meeting of December 6, 2022 with any corrections, deletions, or additions necessary. Motion was seconded by Alderman Jerome. Motion was put to a vote and passed unanimously.

A motion was made by Alderman Hoots to approve the minutes of the Special Called Meeting of December 8, 2022 with any corrections, deletions, or additions necessary. Motion was seconded by Alderman Jerome. Motion was put to a vote and passed unanimously.

DONATION DOCKET

Nick Manley, City Attorney, presented this item to the Board.

DONATION DOCKET 12/20/2022					
Date of Donation	Donation Item	Money Donation	Person / Entity Making Donation	Department	Budget Code
10/18/2022	Check# 003764	\$1,000.00	MID SOUTH OUTLET SHOPS LLC	FIRE	295-626102
11/7/2022	Check # 6024710	\$1,000.00	TEXAS GAS	FIRE	295-626102
10/18/2022	Check # 003765	\$1,000.00	MID SOUTH OUTLET SHOPS LLC	Police	211-626102
Total		\$3,000.00			

Minutes, City of Southaven, Southaven, Mississippi

Alderman Payne made the motion to approve the donation docket. Motion was seconded by Alderman Kelly.

Roll call was as follows:

ALDERMAN	VOTED
Alderman Jerome	YES
Alderman Kelly	YES
Alderman Hoots	YES
Alderman Payne	YES
Alderman Gallagher	YES
Alderman Wheeler	YES
Alderman Flores	YES

Having received a majority of affirmative votes, Mayor Musselwhite declared that the motion was carried on the 20th day of December, 2022.

DIZZY DEAN CONTRACT

Nick Manley, City Attorney, presented this item to the Board.

Mr. Manley stated as the Mayor discussed at the last meeting, this contract has been revised to reflect the current reality with the Dizzy Dean Tournament. The new contract will reflect the payments set forth below by the City and will be based on teams that have entered.

Teams Entered	Sanction Fee
200-225	\$90,000
175-199	\$81,000
150-174	\$63,000
125-149	\$54,000
100-124	\$45,000
75-99	\$36,000
50-74	\$25,000
25-49	\$16,000

The City will provide one (1) team trophy for the champion, runner up, and third place; fifteen (15) to twenty (20) individual player awards for the champion, runner up, and third place, and participation certificates for all World Series players; a meal for all World Series players and coaches in conjunction with the opening ceremonies of the World Series; VIP tournament passes to all Dizzy Dean Officials and families; lunches to all Dizzy Dean Tournament Officials for each day of the World Series; water, soda, sports drinks and ice for Dizzy Dean Tournament Officials for the duration of the World Series; all scaffolding and lifts for TV production personnel; the resources and ability to complete the World Series games in a timely manner; and all administrative staffing, game scheduling, phone hotline, field maintenance, umpire scheduling and staffing, scorekeeper scheduling and staffing and website to keep teams apprised of game results and possible reschedules. The City will pay \$12,000.00 for softball. Alderman

Minutes, City of Southaven, Southaven, Mississippi

Gallagher made the motion to approve the Dizzy Dean contract. Motion was seconded by Alderman Wheeler.

Roll call was as follows:

ALDERMAN	VOTED
Alderman Jerome	YES
Alderman Kelly	YES
Alderman Hoots	YES
Alderman Payne	YES
Alderman Gallagher	YES
Alderman Wheeler	YES
Alderman Flores	YES

Having received a majority of affirmative votes, Mayor Musselwhite declared that the motion was carried on the 20th day of December, 2022.

A copy of the contract is attached and fully incorporated into these minutes.

CONTRACT WITH P.B.J. HAPPEE DAY SHOWS, INC.

Nick Manley, City Attorney, presented this item to the Board.

Mr. Manley stated that this contract with Happee Days, which is the entity that sets up the rides and games for Springfest, provides that the City's compensation is 35% of the Gross Receipts along with \$75.00 per game vendor and \$400 per food vendor. The dates for the contract are April 11-24 so that Happee Days can set up and Springfest will be April 18-22. Alderman Payne made the motion to authorize mayor Musselwhite to sign the contract. Motion was seconded by Alderman Kelly.

Roll call was as follows:

ALDERMAN	VOTED
Alderman Jerome	YES
Alderman Kelly	YES
Alderman Hoots	YES
Alderman Payne	YES
Alderman Gallagher	YES
Alderman Wheeler	YES
Alderman Flores	YES

Having received a majority of affirmative votes, Mayor Musselwhite declared that the motion was carried on the 20th day of December, 2022.

A copy of the contract is attached and fully incorporated into these minutes.

Minutes, City of Southaven, Southaven, Mississippi

RESOLUTION FOR RATIFICATION FOR UTILITIES EMERGENCY EXPENDITURE

Nick Manley, City Attorney, presented this item to the Board.

Mr. Manley stated that this resolution will ratify the expenditure needed at the Getwell Road Water Plant in the amount of \$9,490.00 to replace the high service pump so that there would not be water quality issues. Alderman Hoots made the motion to approve the emergency purchase. Motion was seconded by Alderman Jerome.

Roll call was as follows:

ALDERMAN	VOTED
Alderman Jerome	YES
Alderman Kelly	YES
Alderman Hoots	YES
Alderman Payne	YES
Alderman Gallagher	YES
Alderman Wheeler	YES
Alderman Flores	YES

Having received a majority of affirmative votes, Mayor Musselwhite declared that the motion was carried on the 20th day of December, 2022.

A copy of the invoice is attached and fully incorporated into these minutes.

CONTRACT WITH EVENT CONCESSIONS

Nick Manley, City Attorney, presented this item to the Board.

Mr. Manley stated that this three (3) year contract will authorize Event Concessions to provide, sell, and serve as the merchant of record (collect the money) the merchandise, food, and beverages at the BankPlus Amphitheater for events. As consideration for the City allowing Event Concessions to provide this service, it will pay the City 50% of the Gross Revenue as defined in the contract. Event Concessions will provide the staff for the operations be the entity that works with the POS system for payments, as Event Concessions will work with Fiserv. Motion was put to vote and passed unanimously.

A copy of the contract is attached and fully incorporated into these minutes.

SFD CONTRACTS WITH MISSISSIPPI AMBULANCE ALLIANCE

Nick Manley, City Attorney, presented this item to the Board.

Mr. Manley stated these contracts consists of the Affiliation Agreement and NDA and have been reviewed and recommended by Chief Scallions. The Miss. Ambulance Alliance program provides for enhanced payments to emergency ground ambulance providers, funded by an assessment on their revenue. The assessment will be a percentage (less than 6% - still being determined) of revenue earned from providing emergency ground ambulance services. Every provider

Minutes, City of Southaven, Southaven, Mississippi

will pay the same percentage. In return, the City will receive 100% of the difference between the average amount it would have received from commercial payments and the amount actually paid by Medicaid for those services provided to Medicaid beneficiaries. Because Mississippi has such a high FMAP rate, every ambulance service that provides a reasonable amount of Medicaid services will see a substantial payment in excess of their tax. Only those providers who transport few Medicaid patients are at a risk of paying taxes in excess of their supplemental payments. Originally, the MAA intended to guarantee each member at least a 5% profit under the program, but recent CMS actions have required the association to eliminate that guarantee. Mississippi Division of Medicaid is currently collecting revenue and commercial payment data from each provider. The NDA requires that the consultants that assist the Mississippi Ambulance Alliance will not disclose any non-public information. Alderman Payne made the motion to authorize Chief Scallions to sign the contracts. Motion was seconded by Alderman Hoots. Motion was put to vote and passed unanimously.

A copy of the contracts are attached and fully incorporated into these minutes.

SFD LICENSING AGREEMENT

Nick Manley, City Attorney, presented this item to the Board.

Mr. Manley stated The SFD is wanting to educate its personnel on the use of digital imagery on emergency scenes and address some of the concerns it has regarding personnel sharing such images. This licensing agreement will authorize Curt Varone to provide the training along with the opportunity to have a perpetual use of the recorded training for future new hires and or refresher opportunities. Alderman Payne made the motion to authorize Chief Scallions to sign the contracts. Motion was seconded by Alderman Wheeler. Motion was put to vote and passed unanimously.

Roll call was as follows:

ALDERMAN	VOTED
Alderman Jerome	YES
Alderman Kelly	YES
Alderman Hoots	YES
Alderman Payne	YES
Alderman Gallagher	YES
Alderman Wheeler	YES
Alderman Flores	YES

Having received a majority of affirmative votes, Mayor Musselwhite declared that the motion was carried on the 20th day of December, 2022.

A copy of the agreement is attached and fully incorporated into these minutes.

Minutes, City of Southaven, Southaven, Mississippi

FY22 AUDIT ENGAGEMENT LETTER WITH WATKINS, WARD, STAFFORD, PLLC

Nick Manley, City Attorney, presented this item to the Board.

Mr. Manley stated that this engagement letter in the amount of \$65,500.00 will authorize the City to work with for the FY 22 audit. Alderman Payne made the motion to authorize Mayor Musselwhite and Alderman At Large, George Payne to sign the engagement letter. Motion was seconded by Alderman Hoots.

Roll call was as follows:

ALDERMAN	VOTED
Alderman Jerome	YES
Alderman Kelly	YES
Alderman Hoots	YES
Alderman Payne	YES
Alderman Gallagher	YES
Alderman Wheeler	YES
Alderman Flores	YES

Having received a majority of affirmative votes, Mayor Musselwhite declared that the motion was carried on the 20th day of December, 2022.

A copy of the Engagement Letter is attached and fully incorporated into these minutes.

RESOLUTION FOR BUDGET AMENDMENT

Nick Manley, City Attorney, presented this item to the Board.

Mr. Manley stated that this resolution will amend the budget to reflect the money restricted for police use from prior period funds to purchase police equipment. After hearing from Mr. Manley, the Board of Alderman considered the following resolution:

RESOLUTION OF THE MAYOR AND BOARD OF ALDERMEN OF THE CITY OF SOUTHAVEN, MISSISSIPPI TO AMEND FY 2022 BUDGET

The Mayor and Board of Aldermen of the City of Southaven, Mississippi (the "City"), considered the matter of amending the 2023 City Budget.

WHEREAS, pursuant to Miss. Code 21-35-25, the City desires to amend its 2023 budget; and

WHEREAS, the City Governing Authorities, as part of this Amendment, desire to utilize the money restricted for police use from prior period funds to purchase police equipment.

Minutes, City of Southaven, Southaven, Mississippi

NOW THEREFORE BE IT RESOLVED AS FOLLOWS:

1. The City Board approves the budget amendment as set forth in Exhibit A and authorizes the Mayor or his designee to take any and all actions for such amendment.
2. If required, the City is authorized to publish within two (2) weeks of this action in the same manner as the final adopted budget. This publication shall contain a description of the amendment, the amount of money and funds affected, and a detailed statement explaining the need and purpose of the amendment.
3. The Mayor or his designee are authorized to take all actions to further effectuate the intent of this Resolution.

Following the reading of the foregoing Resolution, Alderman Wheeler made the motion and Alderman Gallagher seconded the motion for its adoption. The Mayor put the question to a roll call vote, and the result was as follows:

Alderman William Jerome	voted: YES
Alderman Kristian Kelly	voted: YES
Alderman George Payne	voted: YES
Alderman Joel Gallagher	voted: YES
Alderman John David Wheeler	voted: YES
Alderman Charlie Hoots	voted: YES
Alderman Raymond Flores	voted: YES

RESOLVED AND DONE, this the 20th day of December, 2022

A copy of the budget amendment is attached and fully incorporated into these minutes.

CONTRACT WITH ARGO ENTERTAINMENT, LLC

Nick Manley, City Attorney, presented this item to the Board.

Mr. Manley stated that this contract will authorize Argo to provide the firework presentation for the July 4th event at Snowden. The contract is similar to prior years in the amount of \$32,500.00. Alderman Wheeler made the motion to authorize Mayor Musselwhite to sign the contract with Argo Entertainment, LLC. Motion was seconded by Alderman Kelly. Motion was put to vote and passed unanimously.

A copy of the contract is attached and fully incorporated into these minutes.

APPROVAL OF CITY DEPOSITORY

Nick Manley, City Attorney, presented this item to the Board.

Minutes, City of Southaven, Southaven, Mississippi

Mr. Manley stated that recently the city received bids from banks for the City Depository. Bids were received from BankPlus and Cadence (formerly BancorpSouth). Cadence provided a higher interest rate of 2.85% or Fed Target minus 95 basis points (maximum of 3.5%) and agreed not to charge fees. Based on the higher interest rate of 2.85% and the stability provided by a fixed rate as opposed to variable rate, the recommendation is to stay with Cadence for a four (4) year term as the City's depository as further detailed in Edi McIlwain's memo. Alderman Hoots made the motion to award the depository bid to Cadence Bank. Motion was seconded by Alderman Payne.

Roll call was as follows:

ALDERMAN	VOTED
Alderman Jerome	YES
Alderman Kelly	YES
Alderman Hoots	YES
Alderman Payne	YES
Alderman Gallagher	YES
Alderman Wheeler	YES
Alderman Flores	YES

Having received a majority of affirmative votes, Mayor Musselwhite declared that the motion was carried on the 20th day of December, 2022.

A copy of the memo and bid tabulation is attached and fully incorporated into these minutes.

RESOLUTION FOR SFD SURPLUS

Nick Manley, City Attorney, presented this item to the Board.

Mr. Manley stated that this resolution will surplus a SFD Vehicle in accordance with Miss. Code 17-25-25. The Board of Alderman considered the following resolution:

RESOLUTION OF THE MAYOR AND BOARD OF ALDERMEN OF THE CITY OF SOUTHAVEN, MISSISSIPPI DECLARING SURPLUS PROPERTY

WHEREAS, the City of Southaven ("City") Fire Department is presently in possession a 2004 Ford Crown Victoria, Fleet Number 5001, VIN 2FAFP74W84X142770 ("Vehicle")

WHEREAS, pursuant to Mississippi Code 17-25-25, it has been recommended to the Mayor and Board of Aldermen that the Vehicle be declared as surplus and sold and/or disposed of as appropriate and in accordance with

Minutes, City of Southaven, Southaven, Mississippi

Mississippi Code 17-25-25, and removed from the fixed assets inventory; and

WHEREAS, the Vehicle shall be surplused pursuant to Mississippi Code 17-25-25(2); and

WHEREAS, the Mayor and Board of Aldermen are desirous of disposing of the Vehicle and amending, its fixed assets inventory pursuant to State guidelines; and

NOW, THEREFORE, BE IT ORDERED by the Mayor and Board of Aldermen of the City of Southaven, Mississippi as follows, to wit:

1. The Vehicle be hereby declared as surplus property pursuant to Mississippi Code 17-25-25(2) and 17-25-25(5).
2. The City Fire Chief, or his designee, is hereby authorized and directed to any and all actions to effectuate the intent of this Resolution.

Motion was made by Alderman Payne and seconded by Alderman Hoots, for the adoption of the above and foregoing Resolution, and the question being put to a roll call vote, the result was as follows:

Alderman William Jerome	voted: YES
Alderman Kristian Kelly	voted: YES
Alderman George Payne	voted: YES
Alderman Joel Gallagher	voted: YES
Alderman John David Wheeler	voted: YES
Alderman Charlie Hoots	voted: YES
Alderman Raymond Flores	voted: YES

RESOLVED AND DONE, this 20st day of December, 2022.

RESOLUTION TO CLEAN PRIVATE PROPERTIES

Mayor Musselwhite introduced the cleaning of property and asked if there were any comments from the Board and there were none. Mayor Musselwhite then asked for any comments from the public and there were none. The Board then considered the following resolution to clean private property:

RESOLUTION GRANTING AUTHORITY TO CLEAN PRIVATE PROPERTY

WHEREAS, the governing authorities of the City of Southaven, Mississippi, have received numerous complaints regarding the parcel of land located at the following address, to-wit:

Minutes, City of Southaven, Southaven, Mississippi

CONDEMNATION ADDRESS

7885 Highway 51
7593 Millbridge Dr
253 GOODMAN RD. W

to the effect that the said parcel of land has been neglected whereby the grass height is in violation and there exist other unsafe conditions and that the parcel of land in the present condition is deemed to be a menace to the public health and safety of the community.

WHEREAS, pursuant to Section 21-19-11 of the Mississippi Code Annotated (1972), the governing authorities of the City of Southaven, Mississippi, provided the owners of the above described parcel of land with notice of the condition of their respective parcel of land and further provided them with notice of a hearing before the Mayor and Board of Aldermen on Tuesday, December 20, 2022, by United States mail and by posting said notice, to determine whether or not the said parcel of land were in such a state of uncleanliness as to be a menace to the public health and safety of the community.

WHEREAS, none of the owners of the above described parcel of land appeared at the meeting of the Mayor and Board of Aldermen on Tuesday, December 20, 2022, to voice objection or to offer a defense.

NOW, THEREFORE, BE IT HEREBY RESOLVED, by the Mayor and Board of Alderman of the City of Southaven, Mississippi, that the above described parcel of land located at:

CONDEMNATION ADDRESS

7885 Highway 51
7593 Millbridge Dr
253 GOODMAN RD. W

is deemed in the existing condition to be a menace to the public health and safety of the community.

BE IT FURTHER RESOLVED that the City of Southaven shall, if the owners of the above described parcel of land do not do so themselves, immediately proceed to clean the respective parcel of land, by the use of municipal employees or by contract, by cutting weeds and grass and removing rubbish and other debris.

Following the reading of this Resolution, it was introduced by Alderman Payne and seconded by Alderman Hoots. The Resolution was then put to a roll call vote and the results were as follows, to-wit:

ALDERMAN

Alderman William Jerome
Alderman Kristian Kelly
Alderman George Payne

VOTED

voted: YES
voted: YES
voted: YES

Minutes, City of Southaven, Southaven, Mississippi

Alderman Joel Gallagher	voted: YES
Alderman John David Wheeler	voted: YES
Alderman Charlie Hoots	voted: YES
Alderman Raymond Flores	voted: YES

The Resolution, having received a majority vote of all Aldermen present, was declared adopted on this, the 20th day of December, 2022.

CITY OF SOUTHAVEN, MISSISSIPPI BY

PLANNING AGENDA

Planning Agenda presented by Whitney Cook, Director of Planning & Development.

Item #1 Application by West Realty Partnership, LP to revise the PUD uses and design for 113.3 acres of property on the south side of Church Road, both sides of Airways Blvd.

Mrs. Choat-Cook stated that the applicant is requesting to rezone 113.3 acres south of Church Road on the east and west sides of Airways Blvd. The applicant is a family who owns the property, and the request is provide a general master design to assist the family in marketing the plan for sale to a developer who can then submit a more defined design detail as the development moves forward. The goal of this master plan is to create a road network and detention plan that will allow the overall development to work. The details included in this plan identifies those components while also providing a general use description for blocks of areas. Exclusions to the permitted uses for each area have been identified in the text and should be referenced in discussion. Also included in this submittal is the identification of major mature tree growth and a conceptual design that will embrace those areas and preserve them.

Mrs. Choat-Cook stated that staff has a couple of concerns/questions:

1. The heated minimums are addressed for Area C and G but not Area F. Can the applicant provide those heated minimums as well?
2. Elmore Road is a section line road which will require right of way from other parties. The applicant has discussed the options for this road but staff would like to clear up the concept and responsibility for the road extension.

Mrs. Choat-Cook made the recommendation to approve as submitted. Alderman Gallagher made the motion to approve the application by West Realty Partnership, LP. Motion was seconded by Alderman Payne.

Roll call was as follows:

ALDERMAN	VOTED
Alderman Jerome	YES

Minutes, City of Southaven, Southaven, Mississippi

Alderman Kelly	YES
Alderman Hoots	YES
Alderman Payne	YES
Alderman Gallagher	YES
Alderman Wheeler	YES
Alderman Flores	YES

Having received a majority of affirmative votes, Mayor Musselwhite declared that the motion was carried on the 20th day of December, 2022.

A copy of the staff report, conceptual land use plan, area enlargement with existing topography, map of existing utilities, and street design are attached and fully incorporated into these minutes.

Item #2 Application by SMJ Enterprise, LLC to revise the PUD design for 144 acres on the north side of Nail Road, west of Getwell Road

Mrs. Choat-Cook stated that the applicant is requesting to rezone 144 acres on the east side of Tchulahoma Road north of proposed Nail Road from the Snowden Farms PUD to Serenity Pointe PUD. This area includes mixture of low density, medium density, high density attached and assisted living.

Mrs. Choat-Cook stated that staff has a couple of concerns/questions/recommendations:

Area A:

- The applicant references cottage homes and townhomes but there is not determination on which is proposed and where? Staff would like further definition on the options in this area.
- The density estimate for the assisted living and number of stories should be identified. Staff understands that the master plan identifies the potential use but the rooms in this area will assist staff in calculating overall density and other bulk regulations. Can the applicant provide an estimated room count?
- Are there design guidelines for the homes proposed? Are there private garages which would negate the need for parking lots? Are there common parking areas for guests?
- Are the interior roads private?

Area B:

- To ensure the quality of these smaller cottage lots, we need to make sure that garages are set back, front porches are included, materials and design mimic cottage style homes similar to those in the Silo Square area.

Area C:

- Staff has no comment.

Minutes, City of Southaven, Southaven, Mississippi

Area D:

- Tchulahoma Road will require some improvements in terms of a widened area for decel which needs to be studied and agreed upon by both staff and the applicant;

Area E:

- Minimum heated square footage has not been addressed.
- Design guidelines for driveways should be discussed.
- Mail accessibility (cluster? Is that needed or will we propose individual?)
- Is this the best option for this area? Do we want driveway traffic on a collector street between two other collector roadways? Additional questions/comments for overall site:
- Fencing materials for the perimeter fence.

Staff would like to see a more decorative design instead of the proposed six foot wood fence.

- Open space should be increased to meet the minimum 20% required by PUD zoned areas;
- The intersection of Nail Road and Tchulahoma Road will be highly visible, staff would like to see a landscape enhancement plan for the hard corner around the pond with or without subdivision signage.
- Parking pads for cluster mailboxes?
- Increased diversity of landscaping along perimeter where lots backyards are up against major roads.
- Tchulahoma Road portion will need to carry the existing pedestrian trail down the length of the Tchulahoma area and pick up where the Nail Road extension should incorporate it. The typical sections shown in the PUD booklet should revise to match.
- Nail Road typical section needs to be adjusted to match the typical section from city designers. The applicant will be responsible for the cost and/or build out of the northern portion of Nail Road (CL to property line) along the linear portion of the project. The typical sections shown in the PUD booklet should revise to match.
- The applicant has provided a plan that provides a good mixture of housing options which take into account the surrounding areas and includes good transition areas from those existing developments. Prior to this plans submittal, the land was part of an overall PUD which was designed with cross access and a good internal flow of the street systems. The city required Silo Square to carry on that circulation and allow for road extensions to both the north and south development areas. That being said, this plan needs to acknowledge and address those points of access. Both area C and D have a stub out designed in Silo Square that is proposed to carry south into this development. While staff understands that

Minutes, City of Southaven, Southaven, Mississippi

both of these areas are gated, it will be required to provide this access. The applicant is welcome to look at different options on these connections to keep the gated community intact which could include incorporating the same gate system as the main entrance or providing a simple secured emergency access gate.

- The applicant will need to decide the accessibility of the gated areas so that the city can determine ownership of the roads. The AG handed down an opinion stating that any subdivision that restrict access with gates will own and maintain the roadways within the gated areas; however, if the gates were deemed “passive”, which allow traffic to pull up and the gates open without restriction, then the roads can be dedicated to the city for maintenance and repair. Staff is acceptable to either option but that will need to be determined at this point.

Mrs. Choat-Cook stated that staff believes the PUD to be a positive development which complies with the comprehensive plan and the overall concept for the area. Once the applicant addresses the above stated comments, staff recommends approval.

Alderman Flores made the motion to approve the application by SMJ Enterprise, LLC with the stated comments. Motion was seconded by Alderman Wheeler.

Roll call was as follows:

ALDERMAN	VOTED
Alderman Jerome	YES
Alderman Kelly	YES
Alderman Hoots	YES
Alderman Payne	YES
Alderman Gallagher	YES
Alderman Wheeler	YES
Alderman Flores	YES

Having received a majority of affirmative votes, Mayor Musselwhite declared that the motion was carried on the 20th day of December, 2022.

A copy of the staff report, development plan, master plan, landscape plan, and architectural standards are attached and fully incorporated into these minutes.

MAYOR'S REPORT

CE&I Getwell Road South Widening Project

Alderman Hoots made the motion to authorize Mayor Musselwhite to sign the CE&I contract with Civil Link for the Getwell Road South Widening Project and all contractor's documentation associated with the project. Motion was seconded by Alderman Payne.

Roll call was as follows:

Minutes, City of Southaven, Southaven, Mississippi

ALDERMAN	VOTED
Alderman Jerome	YES
Alderman Kelly	YES
Alderman Hoots	YES
Alderman Payne	YES
Alderman Gallagher	YES
Alderman Wheeler	YES
Alderman Flores	YES

Having received a majority of affirmative votes, Mayor Musselwhite declared that the motion was carried on the 20th day of December, 2022.

Congressional Briefing Trip

Mayor Musselwhite stated that the upcoming congressional briefing trip will be limited to four people including the Mayor. Mayor Musselwhite stated that he will need to know which Alderman are interested in attending and will be requesting trip approval in January. No action was taken.

Mayor Musselwhite presented the 2022 Year-In-Review.

2022 Year-in- Review

Booming Economy...

- Sales Tax Continued Growth Trend
- Internet Sales Tax Growth Trend
- Unassigned Fund Balance Surplus Growth Trend
- New Business Permit Growth Trend
- Metropolitan District and Hotel/Convention Center Progress
- Entertainment District & Silo Square Tremendous Development Progress

Improving Recreational Value...

- BankPlus Amphitheater Enhancement Project Completed
- Parks Enhancement Funding and Plan Extended
- Neighborhood Park Trails & Pavilions in Design
- New Roofs at Snowden Grove Park Underway
- Arena Volleyball Parking Expansion Completed
- Pickleball Courts (4) near Completion
- Perfect Game Baseball Tournament Inaugural Year
- Dizzy Dean World Series Amended Contract Extension

Celebrating our History...

- Archive Library Completed

Minutes, City of Southaven, Southaven, Mississippi

- Tribute Hall First Honoree
- Historical Marker Signs Pending Order

Aggressive Infrastructure Improvement...

- Stateline/Getwell Monument Sign Completed
- Wayfinding Signs Installed at 13 Key Intersections
- Getwell Road South Widening Project Bid and Ready for Construction
- Pepper Chase Road South Extension near Completion
- May Blvd Pedestrian Bridge Completed and Opened
- Snowden Grove Multi-Use Trail Connected to May Blvd Pedestrian Bridge
- Getwell (May to Nail) Multi-Use Trail in Design
- Street Resurfacing (\$4.7 million)
- Rasco/Tchulahoma Traffic Signal Completed
- Driving Desoto Campaign Underway for I-55 Widening
- Drainage Improvement Projects Completed (\$500K)
- Autumn Woods Drainage Project in Design
- Carriage Hills Estates Drainage Project in Design

Public Safety Commitment...

- Police Officer Expansion Plan Success (up 28% in 3 years)
- Fire Hydrant Expansion in Annexed Areas in Final Phase
- Fire Station #5 Critical Decisions for 2023 Completion

Vision for the Future...

- Horn Lake Creek Basin Interceptor Sewer District/Memphis Sewer Funding
- Commercial Medical Zone Created for Future Medical Marijuana Dispensaries
- Property Database in Design for Enhanced Nuisance Property Ordinance

Mayor Musselwhite thanked the BOARD OF ALDERMEN AND CITY TEAM FOR ANOTHER GREAT YEAR!

PERSONNEL DOCKET

Alderman Payne made the motion to approve the Personnel Docket of December 20, 2022 as presented to this Board. Motion was seconded by Alderman Hoots.

Roll call was as follows:

ALDERMAN	VOTED
Alderman Jerome	YES
Alderman Kelly	YES
Alderman Hoots	YES
Alderman Payne	YES

Minutes, City of Southaven, Southaven, Mississippi

Alderman Gallagher	YES
Alderman Wheeler	YES
Alderman Flores	YES

Having received a majority of affirmative votes, Mayor Musselwhite declared that the motion was carried on the 20th day of December, 2022.

CITY ATTORNEY'S LEGAL UPDATE

Mr. Manley stated that the Gardens of Belle Pointe Homeowners Association, Inc. Is in the process of amending its CCRs. Per the existing CCRs, to finalize the amendment, the Association needs the approval of the City of Southaven. Mr. Manley stated that he is requesting that the provision be removed; however, in order for the CCR's to be amended, he drafted a letter for Whitney Choat-Cook, as City Planning Director, signature to provide for the approval after authorization by the Board. The Gardens of Belle Pointe HOA are being amended to not allow for rental properties. Alderman Wheeler made the motion to authorize Mrs. Choat-Cook to send the letter. Motion was seconded by Alderman Gallagher.

Roll call was as follows:

ALDERMAN	VOTED
Alderman Jerome	YES
Alderman Kelly	YES
Alderman Hoots	YES
Alderman Payne	YES
Alderman Gallagher	YES
Alderman Wheeler	YES
Alderman Flores	YES

Having received a majority of affirmative votes, Mayor Musselwhite declared that the motion was carried on the 20th day of December, 2022.

A copy of the letter is attached and fully incorporated into these minutes.

UTILITY BILL ADJUSTMENT DOCKET

UTILITY BILL LEAK ADJUSTMENT DOCKET 12/20/22

The addresses below experienced unforeseen circumstances in their utilities for which no benefit was received.

NAME	HOUS E #	STREET	ADJUSTED AMOUNT	REASON FOR LEAK ADJUSTMENT
PAMELA WALTON	1788	CONERLY DR S	(805.20)	TOILET LEAK
AMY RAINEY	2927	GLENBURY	(22.23)	POOL ADJUSTMENT

Minutes, City of Southaven, Southaven, Mississippi

NEW JEREMIAH BAPTIST CHURCH	3936	NAIL RD	(110.56)	TOILET LEAK
LERON HILL	2597	BLUE RIDGE	(29.64)	POOL ADJUSTMENT
RHONDA THREATT	8079	MARY PAYTON DR	(527.04)	TOILET LEAK
PREACIOUS KINCE	919	MECKLENBURG CV	(161.04)	TOILET LEAK
ENGELKE HOME SALES LLC	8849	CENTRE STREET	(428.09)	SERVICE LINE LEAK
MIKE MALLET	4387	JESSICA DR	(151.28)	TOILET LEAK
GUY FLORENCE	8076	SWINNEA RD	(145.77)	SERVICE LINE LEAK
JAMAL TAYLOR	4647	SWEET FLAG LOOP	(375.50)	TOILET LEAK
CHARLOTTE HAMPTON	7738	CUSTER CV	(34.16)	2 TOILET LEAKS
LUCILLE JOE	839	STOWEWOOD D	(120.31)	TOILET LEAK
WILLIAM DUNAWAY	968	PINE BIRCH PLACE	(78.08)	LEAK ON MAIN SERVICE LINE TO HOUSE
LITISHA COLEMAN	7597	IRIS DR	(92.72)	TOILET LEAK
RUSSELL REED	7184	ARCASTLE LOOP W	(170.80)	TOILET LEAK
LULA MUKES	8854	CAT TAIL CV	(48.80)	TOILET LEAK AND TUB
LUCILLE GERONIMO	8234	MARY PAYTON DR	(165.92)	TOILET LEAK
		TOTAL	(3467.14)	

A motion was made by Alderman Payne to approve the Utility Bill Adjustment Docket of December 20, 2022 in the amount of \$3,467.14. Motion was seconded by Alderman Kelly.

Roll call was as follows:

ALDERMAN	VOTED
Alderman Jerome	YES
Alderman Kelly	YES
Alderman Hoots	YES
Alderman Payne	YES
Alderman Gallagher	YES
Alderman Wheeler	YES
Alderman Flores	YES

Having received a majority of affirmative votes, Mayor Musselwhite declared that the motion was carried on the 20th day of December, 2022.

CLAIMS DOCKET

Minutes, City of Southaven, Southaven, Mississippi

A motion was made by Alderman Payne to approve the Claims Docket of December 20, 2022 in the amount of \$4,202,238.44. Motion was seconded by Alderman Flores.

Excluding voucher numbers:

390794,390795,390822,390887,390921,390974,390991,391042,391222,391259

Roll call was as follows:

ALDERMAN	VOTED
Alderman Jerome	YES
Alderman Kelly	YES
Alderman Hoots	YES
Alderman Payne	YES
Alderman Gallagher	YES
Alderman Wheeler	YES
Alderman Flores	YES

Having received a majority of affirmative votes, Mayor Musselwhite declared that the motion was carried and approved for payment on the 20th day of December, 2022.

Alderman Hoots recused himself and left the room.

SPECIAL CLAIMS DOCKET

Alderman Payne made the motion to approve the Special Claims Docket of December 20, 2022 in the amount of \$17,649.33. Motion was seconded by Alderman Flores.

Roll call was as follows:

ALDERMAN	VOTED
Alderman Jerome	YES
Alderman Kelly	YES
Alderman Hoots	RECUSED
Alderman Payne	YES
Alderman Gallagher	YES
Alderman Wheeler	YES
Alderman Flores	YES

Having received a majority of affirmative votes, Mayor Musselwhite declared that the motion was carried and approved for payment on the 20th day of December, 2022.

Alderman Hoots returned to the room.

EXECUTIVE SESSION

A copy of the Executive Session Minutes are maintained in the City Clerk's Office.

Minutes, City of Southaven, Southaven, Mississippi

There being no further business to come before the Board of Aldermen, a motion was made by Alderman Hoots to adjourn. Motion was seconded by Alderman Gallagher. Motion was put to a vote and passed unanimously December 20, 2022 at 7:45 p.m.

Darren Musselwhite,
Mayor

Andrea Mullen,
City Clerk
(Seal)

All exhibits and attachments are electronically filed in the City Clerk's Office.

**AGREEMENT BETWEEN CITY OF SOUTHAVEN
AND DIZZY DEAN BASEBALL, INC.**

WHEREAS, pursuant to Mississippi Code 21-17-5, the City of Southaven (“City”) Governing Authorities shall have the care, management and control of the City affairs and its property and finances and the power to adopt any resolution with respect to City property; and

WHEREAS, Dizzy Dean Baseball, Inc. (“Dizzy Dean”) is in the business of promoting youth baseball and softball; and

WHEREAS, Dizzy Dean desires for the City to host its annual baseball and softball tournaments, which will attract thousands of people to the City; and

WHEREAS, pursuant to Mississippi Code 17-1-3, the City has the authority to establish parks and recreational facilities and expend money for those purposes; and

WHEREAS, the City, pursuant to Chapter 933 House Bill 1618 of 1993 is authorized to use funds for the promotion of tourism in the City and pursuant to Miss. Code Ann. 17-3-1, the City has determined that Dizzy Dean Tournaments will help advertise and bring into favorable notice the opportunities, possibilities, and resources of the City, and will advance the moral, financial and other interests of the City and the City is authorized to use funds and in-kind services under Chapter 933 House Bill 1619 of 1993 and the City is authorized to use funds and in-kind services under Mississippi Code 17-3-1 for Dizzy Dean Tournaments; and

NOW THEREFORE, for and in consideration of the mutual promises, covenants and stipulations of each party to the other and other good and valuable consideration, the receipt and sufficiency of which is hereby acknowledged, the parties mutually agree as follows:

Designation as Host. The City shall host the Dizzy Dean Baseball and Softball World Series at Snowden Grove Park and Greenbrook Park for the age groups as set forth below and scheduled according to the City’s approved dates in the months of June and July in 2023, 2024, and 2025.

- 2023 through 2025 Dizzy Dean Baseball World Series in the 6, 7, 8, 9, 10, 11, 12, 13, 14 (Sophomore), 16 (Junior) and 19 (Senior) Year Old Age Divisions;
- 2023 through 2025 Dizzy Dean Fast Pitch World Series in the 6, 8, 10, 12, 14, 16 & 18-Year-Old Divisions.

Term. The term of this Agreement shall commence on January 1, 2023 and expire on July 31, 2025.

Compensation. All income from the operations of the Dizzy Dean Baseball and Softball World Series shall be the property of the City. Dizzy Dean shall have no risk of loss and no right to share in any of the proceeds and/or profit from the Dizzy Dean Baseball and Softball World

Series, except that it shall be paid an annual sanction fee by the City in consideration for the City to host the World Series Tournaments as set forth below:

- Baseball:

Teams Entered	Sanction Fee
236-250	\$99,000
226-235	\$95,000
200-225	\$90,000
175-199	\$81,000
150-174	\$72,000
125-149	\$63,000
100-124	\$45,000
75-99	\$36,000
50-74	\$25,000
25-49	\$16,000

- Softball: \$15,000

Additional Compensation. The City shall provide additional compensation as follows:

- Provide the following awards per age division: one (1) team trophy for the champion, runner up, and third place; fifteen (15) to twenty (20) individual player awards for the champion, runner up, and third place, and participation certificates for all World Series players;
- Provide a meal for all World Series players and coaches in conjunction with the opening ceremonies of the World Series;
- Provide VIP tournament passes to all Dizzy Dean Officials and families;
- Provide lunches to all Dizzy Dean Tournament Officials for each day of the World Series;
- Provide water, soda, sports drinks and ice for Dizzy Dean Tournament Officials for the duration of the World Series;
- Provide all scaffolding and lifts for TV production personnel;
- Provide the resources and ability to complete the World Series games in a timely manner;

- h. Provide all administrative staffing, game scheduling, phone hotline, field maintenance, umpire scheduling and staffing, scorekeeper scheduling and staffing and website to keep teams apprised of game results and possible reschedules relieving the Dizzy Dean Tournament Officials of this burden;

World Series Entry Fee(s). In the event Dizzy Dean allows for an entry fee to be charged to the teams participating in the Dizzy Dean World Series, the City agrees to share the entry fee on a 50/50 basis.

World Series Operations. The City will be solely responsible for organizing and conducting the World Series at Snowden Grove Park and Greenbrook Park according to the published rules of Dizzy Dean Baseball and Softball and the municipal regulations of the City. The City will operate and charge fees for the World Series, including all concessions for its own account and at its expense, which shall include the authority to: (i) set fees, charges and prices at Snowden Grove Park and Greenbrook Park, (ii) organize, schedule and conduct the World Series, (iii) hire and compensate administrative, management and operating staff, officials and other necessary personnel, except the Dizzy Dean Tournament Officials responsible for the supervision of on-field play, who will be compensated by Dizzy Dean, (iv) determine menus and merchandise at the concessions, (v) set gate fee / admissions fee structure and (vi) establish all rules and regulations by which activities other than on-field games are conducted.

World Series on-field play will be under the direction of the designated tournament director(s) appointed by Dizzy Dean. Decisions regarding play following inclement weather will be subject to the approval of the Parks & Recreational Director of the City.

Breach and Cure. In the event either party breaches its duties under this Agreement, the other party shall allow a reasonable opportunity for the breach to be cured. However, the City reserves the right to cancel this accepted proposal if it is determined that the Dizzy Dean World Series creates a financial burden to the City and a remedy to correct the burden cannot be reached by the City and Dizzy Dean. Dizzy Dean reserves the right to cancel the accepted proposal if it is determined by Dizzy Dean that the facilities are unacceptable for such World Series or that the World Series are not conducted in the fashion that has been historically acceptable to Dizzy Dean and a remedy to correct the issues cannot be reached by the City and Dizzy Dean. If due to an act of God, the City is unable to perform hereunder or host the tournament, it shall not be deemed to be in breach of this contract, nor shall Dizzy Dean be entitled to or receive damages of any kind therefore.

General.

- a. Each party executing this Proposal represents and warrants that it is duly authorized to do so on behalf of Dizzy Dean and the City for which it has signed.
- b. All notice and other communications hereunder shall be in writing and delivered personally or by e-mail or certified mail.
- c. The laws of the State of Mississippi shall govern this Agreement.

- d. Any changes or modification to this executed Proposal must be in writing and signed by both parties hereto. This Proposal shall be executed in one or more counterparts, each of which shall be deemed and original.
- e. This Agreement shall replace all prior and previous Agreements, Proposals, and shall be binding upon both parties.

In Witness Whereof, the parties hereto have duly executed and delivered this Agreement as of the 22 day of December, 2022.

Dizzy Dean Baseball, Inc.

City of Southaven, MS

By: Danny Phillips, Commissioner

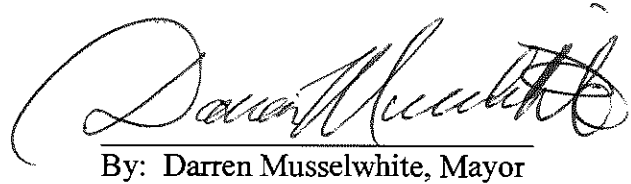
By: Darren Musselwhite, Mayor

**AGREEMENT BETWEEN CITY OF SOUTHAVEN AND
P.B.J. HAPPEE DAY SHOWS, INC.**

This Agreement is made and entered into as of the date of the last signature of the parties hereto, by and between the City of Southaven hereinafter referred to as "City" or "OWNER" and P.B.J. Happee Days Shows, Inc. hereinafter referred to as "LESSEE."

WHEREAS, OWNER manages, maintains, owns, and operates certain park property in Snowden Grove Park and specifically set forth in Exhibit A described as the "Carnival Area," which is the site of the City's Springfest (the "Property"); and

WHEREAS, pursuant to Mississippi Code 57-7-1, the OWNER desires to lease the Property as further set forth herein to LESSEE upon such terms and conditions as the OWNER shall prescribe to further promote commercial development in the City as LESSEE shall provide all equipment, materials, and host a fair, commonly known as "Springfest" for the OWNER, which will attract thousands of people to the City and increase commerce within the City; and

WHEREAS, the OWNER, pursuant to Chapter 933 House Bill 1618 of 1993 is authorized to use funds for the promotion of tourism in the City and pursuant to Miss. Code Ann. 17-3-1, the OWNER has determined that Springfest will help advertise and bring into favorable notice the opportunities, possibilities, and resources of the City, and will advance the moral, financial and other interests of the City and the City is authorized to use funds and in-kind services under Chapter 933 House Bill 1619 of 1993 and the City is authorized to use funds and in-kind services under Mississippi Code 17-3-1 for Springfest; and

WHEREAS, LESSEE desires to have the use of a portion of the Property, and OWNER desires to allow LEASSEE the use of a portion of the Property, as determined by the City, under the terms, condition and provisions contained herein.

NOW, THEREFORE, based upon the terms, conditions, covenants and considerations hereinafter set forth, the parties, intending to be legally bound, hereby agree as follows:

Section 1. Premises. OWNER does hereby Lease and grant the right to use the Property to the LESSEE and the LESSEE does accept for use the Property in accordance with this Agreement.

Section 2. Use. LESSEE shall have use of the Property, as determined by the City, to host the City's annual Springfest Event, consisting of rides, vendors, food, and games (hereinafter the "Event"). This Agreement provides LESSEE with only the right and privilege to possess and use the Property in the manner set forth herein. LESSEE shall sell carnival wristbands for the Event rides on April 18-22, 2023. The OWNER reserves the sole right to charge for admission to enter the Event and shall be entitled to all proceeds from admission.

Section 3. Term. The term of this Agreement commences on the 11th day of April 2023 and terminates on the 24th day of April 2023 (hereinafter the Term). The Event shall be April 18-22, 2023.

Section 4. Lease Fee. (i) LESSEE agrees to pay the OWNER a fee for the use of the Property in the amount of 35% of the Gross Receipts, as defined herein, along with payments to the OWNER in the amount of \$75.00 per game vendor and \$400 per food vendor (collectively, the "Lease Fee"). Payment from LESSEE shall be made to City by April 23, 2023.

(ii) In addition to the above Lease Fee, the LESSEE shall pay all taxes, charges, fees and permits, whether federal, state, county, or city, due on account of its business and the permitted activities engaged in under this Agreement.

(iii) "Gross Receipts" as used herein is defined to mean the total amount of dollars collected for all carnival wristbands sold and carnival tickets sold for the Event rides without deduction.

Section 5. Late Payments. (a) Any Lease Fee, cost, expense or sum due from LESSEE which is not received on the date its due shall be deemed late and LESSEE shall be liable for a late fee of \$50.00 per day, or that maximum amount allowed by law without being deemed a penalty or usurious. Further, LESSEE shall pay accrued interest on the past due amounts, at the rate of one-and-one half percent (1 ½%) per month, until the delinquent sums

Section 6. LEASEE's Personal Property. (a) In the receipt, handling, care or custody of property of any kind shipped or otherwise delivered to the Premises by or for LESSEE, OWNER shall act solely for the accommodation of the LESSEE and neither the OWNER nor any of its agents or employees shall be deemed a bailee, nor be liable for any loss, damage or injury to such property.

(b) Any property left within the Property by LESSEE shall, after a period thirty (30) days from the termination of this Agreement, be deemed abandoned and the OWNER shall have the right to remove, place in storage or otherwise dispose of any such property at the sole cost and expense of LESSEE. LESSEE hereby irrevocably constitutes and appoints the OWNER as its special attorney-in-fact to do and perform all acts necessary in removing, storing and disposing of said abandoned personal property and to execute and to deliver a bill of sale therefore.

(c) OWNER assumes no responsibility for any property of LESSEE, its agents, employees or invitees, and said OWNER is hereby expressly released and discharged by LESSEE from any all liabilities for any loss, injury or damages to said property that may be sustained by reason of the occupancy and use by LESSEE of the Property.

Section 7. Public Announcements. OWNER reserves the right to make public announcements during the Event. LESSEE is prohibited from making public announcements, other than those which pertain to the Event, without prior written approval of the OWNER.

Section 8. Broadcast. The LESSEE will not broadcast, nor permit anyone else to broadcast, via radio, television, cable, satellite, internet or other electronic means, the Event, or any part thereof, produced within the Property,

unless and until the OWNER shall have given its written permission therefore. If any of the conditions of such written permission are violated, the OWNER, at its option, may at any time stop such broadcasting.

Section 9. Right to Inspect. OWNER shall have the right at all times to enter the Property to examine the same and to perform OWNER's duties as deemed necessary by the Owner, including, but not limited to, inspections of all rides, booths, games, and equipment.

Section 10. Default. (a) A default of this Agreement shall be deemed to have occurred hereunder if:

(i) LESSEE fails to pay the Lease Fee within five (5) days of the date its due, or otherwise fails to pay OWNER any amounts or sums to be paid by LESSEE when the same are due.

(ii) LESSEE defaults in the performance or observance of any term, covenant, condition or provision of this Agreement required of the Party, and such default continues for a period of one (1) day after service by the other party of written notice of such default.

(iii) A party ceases to function as a going concern, becomes insolvent, makes an assignment for the benefit of creditors, files a petition in bankruptcy, permits a petition in bankruptcy to be filed against it (which petition is not dismissed within 60 days of its filing), admits in writing its inability to pay debts as they mature, or if a receiver is appointed for a substantial part of its assets.

(b) No waiver by either party of any default or breach by LEASEE of its obligations hereunder shall be construed to be a waiver or release of any other or subsequent default or breach by LEASEE hereunder.

Section 11. Termination.

(a) (i) OWNER has the right to elect to terminate this Agreement, without cause, prior to the Term. Provided, however, that OWNER must give LESSEE twenty (20) days advance written notice of the intention to terminate this Agreement.

(ii) In the event LESSEE fails to pay the Lease Fee when it is due, or otherwise fails to pay OWNER any amounts to be paid by LESSEE when such amounts are due, OWNER may, at its option, immediately terminate this Agreement.

Section 12. Content Restrictions and Right to Control Facility. (i) No performance, exhibition or entertainment shall be given or held at the Event, which is indecent, obscene or immoral, including nudity and graphic obscenities. Should any such performance, exhibition or entertainment or any part thereof, be deemed by the OWNER to be indecent, obscene, immoral, or in any manner publicly offensive, OWNER shall have the authority to stop such event or to demand the removal of the objectionable subject. If the OWNER should exercise its prerogative hereunder, all Lease Fees and other costs and expenses due to OWNER will remain the property of the OWNER and any unpaid charges arising under this Agreement shall be considered payable to OWNER. (ii) OWNER reserves the right to eject or cause to be ejected from the Event any person or persons acting in contravention to this provision. The OWNER shall not be held liable to the LESSEE for its actions under this paragraph. (iii) Any artisans or workmen employed by LESSEE and may

66751273.v1

be refused entrance by OWNER, or its employees, agents or representatives for non-compliance with the provisions of the Agreement or for objectionable or improper conduct. Refusal of entrance by OWNER shall be without liability on the part of OWNER or its employees, agents and representatives.

Section 13. Lawful Activity. In carrying out its obligations under this Agreement, LESSEE shall comply with all rules, regulations, laws and ordinances of the United States, the State of Mississippi, County of DeSoto, the City of Southaven and those established by the OWNER. The LESSEE will not do, nor suffer to be done, anything on or within the Property, in violation of any laws, ordinances, rules or regulations. If the attention of the LESSEE is called to any violation of the same on its part, or of any person employed by it or admitted to the Event, the LESSEE will immediately desist and correct the violation. The LESSEE shall have the responsibility for obtaining all permits or Leases required of it by said laws, ordinances, rules and regulations

Section 14. Insurance. LESSEE shall furnish the OWNER not less than ten (10) days in advance of the Term, a certificate showing that there is in force a policy of public liability insurance in the form of comprehensive general liability insurance, in which the LESSEE is named as an insured and the OWNER as an additional insured, with limits of not less than \$1,000,000 single limit and \$2,000,000 aggregate coverage for the duration of the Term. All insurance policies must reflect that it may not be canceled prior to the conclusion of the Term. The policy must also reflect coverage for bodily injury or death. LESSEE waives any right of subrogation against OWNER in connection with any insurance proceeds received by or due to OWNER.

Section 15. Indemnification. LESSEE agrees to conduct its activities upon or within the Property so as not to endanger any person thereon and to indemnify, defend and save harmless the OWNER and OWNER's agents, employees, directors, contractors, and officials against any and all claims, costs or expenses, loss, injury, death, or damage to persons or property, including claims of employees of the LESSEE, or LESSEE's contractors, independent contractors, or subcontractors arising out of the negligence, acts, or failures to act by the LESSEE, its contractors, independent contractors, subcontractors, agents, members, invitees, or guests. LESSEE will not do or permit to be done anything in or upon any portion of the Property, or bring or keep anything therein or thereon, which will in any way conflict with the conditions of any insurance policies insuring the Property or any part thereof against loss. The presence of policemen, firemen, EMS personnel, inspectors or representatives of the OWNER shall in no event diminish or affect the duties, obligations or responsibilities of the LESSEE hereunder.

Section 16. Liens. The LESSEE agrees to save the OWNER harmless from and indemnify it against any such cost, expenses and charge and from and against all claims, demands and liens of whatever character arising by reason of contract, express or implied, or negligence, or any other act of omission on the part of any person, firm or corporation other than OWNER, including all cost, expenses, and attorneys' fees incurred by OWNER in responding to any asserted claim, demand, or lien.

Section 17. Event Cancellation. OWNER has, at all times, final approval and control over any decision or

decisions related to the cancellation of the Event.

Section 18. Copyright. (i) The LESSEE agrees to assume full responsibility for complying with, and to indemnify, defend and save harmless the OWNER against any and all claims, costs or expenses, loss, injury, or damage arising out of any claim for violation of, the Federal Copyright Law of 1978 (17 U.S.C. 101 et seq.), as amended, Trademark Act of 1946, as amended and any other Federal and State laws applicable to the use of intellectual property, and any regulations issued there under, including but not limited to the assumption of any and all responsibilities for paying royalties which may be due for the use of copyrighted work and trademarks used in connection with the Event.

(ii) Unless otherwise expressly provided herein, or otherwise agreed to by the parties, each party shall retain all right, title and interest, in and to all intellectual property held by the party, or Leased to the party, and the other party is granted no right, title, interest, or Lease in or to such other party's intellectual property rights. Notwithstanding the foregoing, LESSEE grants to OWNER the right to use images and depictions of the Event or Event advertising as part of its marketing, promotion and advertising of the City and/or the advertising opportunities available therein.

Section 19. LESSEE's Assurance. LESSEE hereby certifies and guarantees that it has a valid and properly executed contract with the performer(s), exhibitor(s), or other person(s) whose services form the basis of the Event.

Section 20. Assignment. The LESSEE shall not assign this Agreement or any rights hereunder, and any attempt to sell or assign this Agreement or any rights hereunder shall thereby terminate this agreement.

Section 21. Ingress/Egress. All articles, exhibits, fixtures, materials, displays, rides, equipment, staging, and lighting of the LESSEE shall be brought into or taken on the Property only at such locations as may be designated by the OWNER.

Section 22. Parking. OWNER reserves the exclusive right to control parking for the Property, including the right to contract with third parties for parking services or management. Any revenues derived from parking shall be retained solely by OWNER.

Section 23. Interruptions. OWNER shall retain the right to cause the interruption of the Event in the interest of public safety, and to likewise cause the termination of the Event when, in the sole judgment of the OWNER based upon reasonable circumstances, such act is necessary in the interest of public safety. In such event, LESSEE waives any and all claims for damages or compensation from OWNER.

Section 24. Force Majeure. In the event the Property or any part thereof shall be destroyed or damaged by any cause beyond the control of the parties, or such events beyond the control of the parties prevents the fulfillment of this Lease by the OWNER impossible including, but without limitation thereto, flood, earthquake, acts of God, failure of utilities, the requisitioning of the premises by any governmental agency, pandemic, COVID, riot, public disorder, violent demonstrations, civil commotion, labor dispute between the OWNER and its employees, agents, contractors or subcontractor, and other unforeseeable circumstances beyond the control of the parties which the affected party cannot avoid even by using its best efforts, then this Lease shall terminate. Lessee hereby waives any claims for damages or

66751273.v1

compensation, demands, and causes of action it may have against the OWNER should this Lease be so terminated.

Section 25. Rules and Regulations for Facility Use. OWNER shall retain at all times the right to manage, operate and regulate the use of the Property. OWNER may promulgate rules and regulations, from time to time, regarding the use, occupancy and operations of the Property. LESSEE agrees to abide by all such rules and regulations as adopted by OWNER.

Section 26. Miscellaneous.

a. Situs. The situs of this Agreement is Southaven, Mississippi, and any action, claims, suits or disputes arising hereunder shall be governed by the law of the State of Mississippi.

b. Paragraph Headings. The paragraph titles herein are for convenience only and do not define, limit or construe the contents of such paragraphs.

c. No Agency. Nothing herein shall be construed so as to make LESSEE the agent, employee or representative of OWNER for any purpose.

d. Waivers and Modifications. No waiver of any provision hereof, shall be effective unless stated in writing and signed by the OWNER and LEASEE. No such waiver shall constitute a waiver of the same provision on a subsequent occasion nor of any other provision of this Agreement.

e. Entire Agreement. This Agreement, with items incorporated by reference, shall constitute the entire agreement between the parties, unless modified in writing and executed by OWNER and LESSEE.

f. Attorney Fees and Costs. In the event of default by LESSEE of any terms of this Agreement, LESSEE shall be liable to OWNER for all reasonable attorney's fees, costs and other legal expenses incurred as a result thereof.

g. Force and Effect. This Agreement shall have no force or effect unless fully executed and may be executed in counterparts, which shall each be deemed an original.

h. Severability. If any provision of this agreement, or the application of such provision to any person or circumstance, shall be held invalid, the remainder of this agreement, or the application of the remainder of this agreement to persons or circumstances other than those to whom or to which it is held invalid, shall not be affected thereby.

i. Authority to Sign/Counterparts. The parties each represent that the person executing this document on behalf of such party has the power and authority to enter into this Agreement and such entity has the authority to consummate the transactions herein contemplated. The execution and delivery hereof and the performance by each party of its obligations hereunder will not violate or constitute an event of default under the terms or provisions of any agreement, document or other instrument to which it is a party or by which it is bound. All proceedings required to be taken by or on behalf of each party to authorize it to make, deliver and carry out the terms of this Agreement have been or will be duly and properly taken by each party and this Agreement is the legal, valid and binding obligation of the parties and is enforceable in accordance with its terms. This Agreement may be executed in more than one counterpart, each of which shall be deemed an original.

j. Owner Naming Rights. LESSEE acknowledges that OWNER is bound to the marketing and advertising restrictions and prohibitions as set forth in OWNER'S Agreement with BankPlus. LESSEE shall not undertake the marketing and selling of any advertising which would be contradictory to, or result in any breach of, the BankPlus Naming Agreement. Further, Lessee shall not undertake the marketing and selling of any advertising which constitutes a naming rights agreement, or partial naming rights agreement, without the express written consent of Owner.

k. Impermissible Provisions Notice. LESSEE is on notice that the City is a body politic of the State of Mississippi and that Mississippi law provides that it is the duty of those contracting with a Mississippi public entity to see to it that the provisions of the contract are legal and enforceable. Notice is given that the City will not be bound to any provision of the contract which a Mississippi public entity cannot legally agree to or contract for. In executing the enclosed contract, the City does not waive any rights it may have to object to, contest, or refuse to comply with any provision of the contract that is impermissible by operations of the laws of the State of Mississippi.

l. Gun and Weapon Notice. LESSEE, as a private entity, states that it chooses to not allow any weapons of any kind on the Property during the term of this Lease agreement.

IN WITNESS WHEREOF, this Agreement has been executed by LEASEE the 24 day of December 2022, and shall become effective and binding upon the parties upon the acceptance hereof by OWNER, as evidenced by the execution hereof by its duly authorized officer.

CITY OF SOUTHAVEN

BY: 

TITLE: MAYOR

LESSEE:

BY: 

TITLE: President

Exhibit A

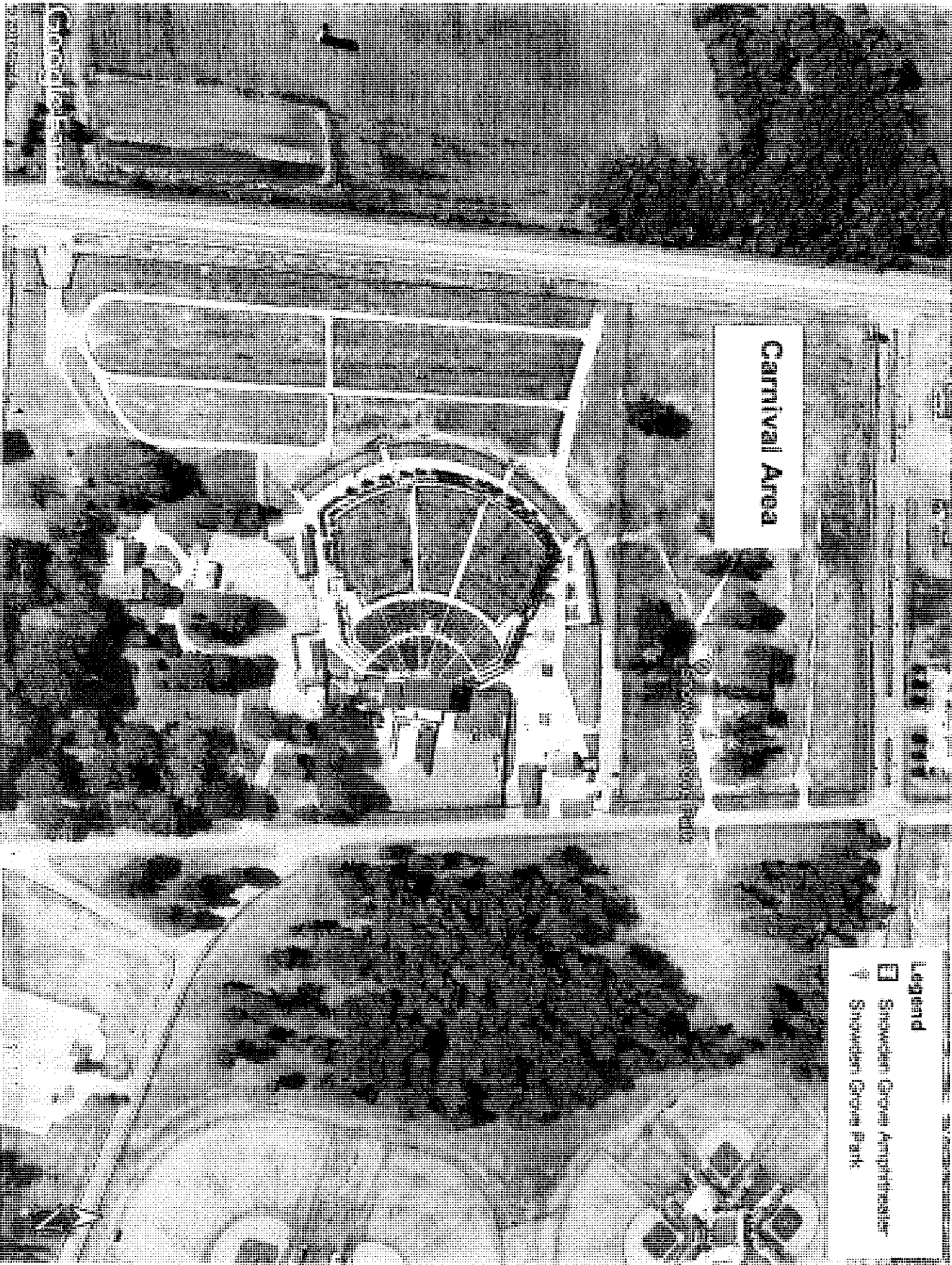

Carnival Area

Legend

□ Snowden Cove Amphitheater

▲ Snowden Cove Park

**RESOLUTION OF THE MAYOR AND BOARD OF ALDERMEN OF THE
CITY OF SOUTHAVEN, MISSISSIPPI FOR DECLARATION OF
EMERGENCY EXPENDITURE**

WHEREAS, the City of Southaven ("City") pursuant to Mississippi Code Section 31-7-13(k) hereby ratifies the expenditures associated with the emergency purchase for the Getwell Water Plant for the immediate preservation of order and public health to ensure water to the City's citizens; and

WHEREAS, the purchase was necessary to ensure the health and safety of the City's citizens in context of drinking water; and

NOW, THEREFORE, BE IT RESOLVED BY THE GOVERNING BODY, ACTING FOR AND ON BEHALF OF THE CITY, AS FOLLOWS:

SECTION 1. Pursuant to Mississippi Code 31-7-13(k) and recommendation of the City's Utilities Director, the City Board ratifies the expenditure in the amount of \$9,490.00 for the Getwell Water Plant emergency purchase of a motor as set forth in Exhibit A.

SECTION 2. On behalf of the City, the Mayor or his designee is authorized to take all actions to effectuate the intent of this Resolution.

Following the reading of the foregoing resolution, Alderman Hoots made the motion to adopt the Resolution and Alderman Jerome seconded the motion for its adoption. The Mayor put the question to a roll call vote and the result was as follows:

Alderman William Jerome	voted: YES
Alderman Kristian Kelly	voted: YES
Alderman Charlie Hoots	voted: YES
Alderman George Payne	voted: YES
Alderman Joel Gallagher	voted: YES
Alderman John Wheeler	voted: YES
Alderman Raymond Flores	voted: YES

RESOLVED AND DONE, this 20th day of December, 2022.



DARREN MUSSELWHITE, MAYOR

ATTEST:

CITY CLERK

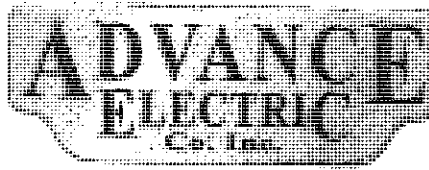

Advance Electric Co., Inc.
10500 Highway 178
Olive Branch, MS 38654
Phone: (662) 895-6335
Fax: (662) 895-6361



Invoice
27333

INVOICE

SOLD TO City of Southaven
8710 Northwest Drive
Southaven, MS 38671
Attn: Ray Humphrey

SHIP TO Cty S'havn Trblsht W Hgh Serv

ACCOUNT NO	PO NUMBER	TERMS	INVOICE DATE	PAGE
CITSOU		Net 30	11/30/2022	1

Troubleshoot West High Service Pump at the WTP on Getwell.
Motor found to be bad.
Ordered new replacement motor and hand delivered to the facility.

DESCRIPTION	EXTENDED
Project No. SC27351	9,490.00
Work was performed in Southaven, Desoto County, MS	

Thank you for your business.

TOTAL AMOUNT 9,490.00

Do you have an email address for future Accounts Payable Invoices?
If so, please email address to: Ann Braun, abraun@advance-electric.net

PO # _____
VENDOR # 16939
INVOICE # _____
AMOUNT \$9,490.00
DESCRIPTION EMERGENCY REPLACEMENT
MOTOR FOR GETWELL WATER PLANT
DEPT. CODE 815-625300

PROFESSIONAL SERVICES AGREEMENT

This PROFESSIONAL SERVICES CONCESSION AGREEMENT ("Agreement") is entered into as of the ___ day of December 2022 by and between the City of Southaven, Mississippi 8710 Northwest Drive, Southaven, Mississippi (Licensor), and Event Concessions Inc at 355 Hwy 361, Pelham, AL 35124 ("Licensee"). In consideration of the mutual representations and provisions made herein, the receipt and sufficiency of which are hereby acknowledged, the parties agree as follows:

WITNESSETH

WHEREAS, Licensee desires the exclusive right and privilege to provide professional services to operate the food and beverage concessions ("Concessions") at the certain entertainment venue, commonly known as "The BankPlus Amphitheater" located in Southaven, Mississippi (Amphitheater);

WHEREAS, Licensor desires to have Licensee operate the Concessions at the Amphitheater, on the terms and conditions set forth herein.

NOW, THEREFORE, in consideration of the foregoing and of the mutual covenants, agreements, promises, representations and warranties hereinafter set forth, Licensor and Licensee agree as follows:

1. License

- a. **Scope of License.** Subject to all of the terms and conditions herein, Licensor hereby grants Licensee the right and privilege to maintain and operate the Concessions at the Amphitheater which includes, but is not limited to, the following rights and obligations: (1) supplying merchandise for sale; (2) providing vendors to sell merchandise; (3) operating concession stands at the Amphitheater.
- b. **Exclusivity.** The exclusive concession privilege hereby granted shall apply to all Events conducted at the Amphitheater during the Term of this Agreement.

2. Definitions. As used herein, the following term shall have the following meaning:

- a. **Event(s).** Live music, variety or other entertainment events produced by Licensor or a third party at the Amphitheater.

3. Term / Termination.

- a. **Term.** The initial term of this Agreement shall commence thirty (30) days after the completion of the Amphitheater as evidenced by a Certificate of Substantial Completion issued by the Licensor's Architect and shall continue thereafter for a period of thirty-six (36) months (the "Term").

b. Termination.

i. Licensor may terminate this Agreement at any time for convenience during this Agreement upon at least sixty (60) days written notice to Licensee of its intent to terminate this Agreement.

ii. In the event the Licensor terminates this Agreement after the commencement of the initial term and within the dates of April 1st through October 31 for reasons other than for Cause, i.e., the failure of the Licensee to pay the amounts specified herein as and when due hereunder and the continuance of such failure for a period of ten (10) days after written notice from Licensor to Licensee specifying such failure and/or the failure of either party to perform, comply with or observe any other material agreement, obligation or undertaking, term, condition or provision, in this Agreement and the continuance of such failure for a period of ten (10) days after receipt by the party in breach of written notice from the non-breaching party of such failure to perform, the Licensor shall pay to Licensee the sum of \$15,000.00 as reimbursement for mobilization and other start-up costs incurred by the Licensee in the performance of this Agreement which payment shall be made on a pro-rated basis based on the time of such termination. For example, if the Licensor terminates this Agreement for reasons other than for Cause five (5) months after the commencement of the initial term of this Agreement, the City will pay Licensee the sum of \$11,875.00 (\$15,000.00 — \$3,125.00 (5 months at \$625.00)). Licensee acknowledges that the Licensor shall not be obligated to pay any sums under these provisions if this Agreement is terminated by the Licensor prior to the commencement of the initial *term* of this Agreement

4. Office Space. Licensee shall be permitted occupancy, to the exclusion of all others except Licensor, of the concession buildings at the Amphitheater and, to the extent available, provided adequate office space and storage space.

5. Goods.

a. Licensee's Obligations. Licensee shall order, stock, prepare and sell food and beverages (alcoholic and non-alcoholic). Title to said merchandise shall remain vested in the Licensee or the cosigner of the goods as the case may be.

b. Quality / Price of Goods. The type, quality and price of food and beverages will be mutually agreed upon by the Licensor and the Licensee.

6. Posted Prices. During all events, Licensee shall post signs advertising the prices of items offered for sale. All signs shall be approved by the Licensor and in conformity with the Licensor's signs throughout the Amphitheater. Licensor will provide signage as determined by Licensor's sole discretion.

7. Hours of Operation. Licensor shall have the exclusive right to determine the Licensee's hours of operation. The concession stands to be operated by Licensee for a particular Event shall be open continuously throughout such period of time.

8. Permits and Licenses. It shall be the responsibility of Licensee to obtain all appropriate licensing and / or permits for the food and beverages (including alcoholic beverages) required by all applicable federal, state and local laws and have copies of such permits on site throughout the entire *run* of the Term. If, upon inspection by the applicable authority, Licensee

is not in compliance, then Licensee agrees to, if directed, to shut down its operations immediately. All fees, dues or payments associated with meeting the above-mentioned stipulations are at the Licensee's sole expense. Licensee shall be required to obtain all necessary licensing and/or permits of all personnel that will be involved in the serving of alcoholic beverages. Licensor will be responsible for the 1st health inspection after construction but Licensee may have a representative present for the inspection.

9. Fees. Licensee shall remit to Licensor a fee (the "Fee") for each event to be calculated in accordance with the following: Licensee will pay Licensor Fifty percent (50%) of these gross revenues as defined herein. A fee, if any, for private or free events will be negotiated on an event basis. Any-modification shall be reduced to writing, executed by the parties and included as an addendum to this Agreement.

a. "Gross Revenues". The term "gross revenues", for the purposes of the calculation set forth herein, shall be the total amount of all sales proceeds received by Licensee pursuant to its operation of the concession stands and liquor bars at the Amphitheater excluding however: (i) any and all applicable Federal, state and local sales and use taxes; (ii) value added taxes; (iii) license fees, taxes and any concessionaire or similar taxes not measured by net income; (iv) credit/debit card charges/fees, check approval fees and charges; and (v) all governmentally imposed charges similar to those set forth in (i)-(iii), now or hereafter imposed upon Licensee in respect of sales or rentals by Licensee pursuant hereto.

10. Payment Schedule. Licensee shall remit the Fee to Licensor on a monthly basis, remitting payment by the 15th for the month prior.

11. Use of Equipment. Licensee shall be permitted use of Licensor's concessions equipment and concession stands and liquor bars located at the Amphitheater. Licensee shall maintain said equipment in good repair, ordinary wear and tear excepted. However, Licensor shall be responsible for replacement cost and or major repairs required on said equipment unless arising from Licensee's negligence or intentional acts. Major repairs are defined as any repair in excess of one hundred and fifty dollars (\$150). All items shall be replaced or repaired in a timely basis so as not to disrupt Licensee's ability to provide concessions under this agreement. Licensor shall be responsible for the annual or semi-annual maintenance including a pre-season cleaning done by a licensed professional company. Pre-season cleaning would be things such as hood cleaning and ice machine clean outs. Licensee shall be responsible for any and all cleaning after each event and/or use by Licensee.

The Licensor will provide ice merchandisers, along with electric and manual pallet jacks, on event days for Licensee use.

12. Security. Licensee shall be responsible for its own security with respect to equipment, goods or supplies. Licensor shall not be responsible for the theft of or damage to any items or vehicles brought to the premise by Licensee, its subcontractors, agents, employees or representatives. Notwithstanding the foregoing, it is understood by the parties that the concession stands are located on common areas where parties other than Licensee has access. Licensee will accept responsibility for its equipment and supplies, it will not be held

accountable for damage to other equipment, goods or supplies that are not under its exclusive control.

13. **Staffing.** All staff members must wear clean, professional looking uniforms. Licensee shall be responsible for all the costs and expenses necessary to provide the afore-described staffing under this Agreement, including, but not limited to, labor, equipment, supplies, uniforms and insurance.

14. **Insurance.** Licensee shall maintain and pay all premium costs for the following insurance coverages in amounts not less than specified below and shall furnish Licensor with Certificates of Insurance evidencing compliance with the following provisions:

- a. Statutory Workers' Compensation including Employer's Liability Insurance, subject to limits of not less than \$500,000, affording coverage under the Workers Compensation laws of the State of Mississippi. Each Licensee shall cause, if allowed by law, its workers compensation carrier to waive insurer's right of subrogation with respect to Licensor, its partners, parents and affiliated companies.
- b. Commercial General Liability Insurance, including Liquor Liability, for limits not less than \$1,000,000 per occurrence Bodily Injury and Property Damage combined; \$1,000,000 per occurrence Personal and Advertising Injury; \$2,000,000 aggregate Products and Completed Operations Liability; \$1,000,000 Liquor legal liability; \$100,000 Fire Legal Liability; and \$2,000,000 general aggregate limit per location. The policy shall be written on an occurrence basis.
- c. Umbrella Liability Insurance at not less than \$2,000,000 limit providing excess coverage over all limits and coverages noted in sections (a) and (b) above. This policy shall be written on an occurrence basis.
- d. Adequate casualty and personal property insurance sufficient to provide coverage for all of Licensee's personal property, inventory and goods.

The policies set forth in sections (b) and (c) above shall be endorsed to name Licensor, its employees and agents as "Additional Insured" with respect to any and all claims arising from the performance of Licensee's services. Further, coverage for the "Additional Insured" shall apply on a primary basis irrespective of any other insurance, whether collectable or not, only to the extent of Licensee's liability.

Should any additional premium be charged for such coverages or waivers, Licensee shall be responsible to pay said additional premium charge to their insurer. All insurance furnished by Licensee hereunder shall be in full force and effect at all times during the performance of the services by Licensee and for a period of two years after performance.

Licensee shall deliver to Licensor satisfactory evidence of the aforementioned insurance coverage on a certificate form approved by Licensor, or, if required, copies of the policies. All required insurance will be placed with carriers licensed to do business in the applicable states and rated no lower than A-: 10 in the most current edition of A.M. Best's Property Casualty Key Rating Guide and will provide thirty (30) days written notice of cancellation or non-renewal which notice shall be forwarded to Licensor. The stipulated

limits of coverage above shall not be construed as a waiver of Licensee's obligation to provide the insurance coverage specified.

15. Indemnification.

Licensee hereby agrees to indemnify, defend (by counsel acceptable to Licensor) and hold Licensor its partners, officers, officials, directors, employees, agents and representatives, ("Indemnified Parties") free and harmless against any and all claims, damages, liability, loss, costs and expenses, including attorney fees arising out of or connected with or related to any claim, injury, or legal action by any person to the extent it results from (i) any acts or omissions of Licensee, or its officers, directors, employees, agents, vendors or others working for and/or on behalf of Licensee whether or not such acts or omissions amount to negligence or (ii) the negligence or willful misconduct of Licensee or of any of Licensee's officers, directors, agents, employees, vendors or others working for and/or on behalf of Licensee.

16. Accounting Records. Licensee shall maintain complete and accurate records of all inventories managed for the Term (including product, equipment, personnel, etc.) and all financial transactions hereunder. Licensor may, upon written notice to Licensee and during normal business hours, audit and inspect Licensee's books and records pertaining to the Services for three (3) years after the termination of this Agreement.

17. Compliance with Laws. At all times Licensee shall comply with all federal, state, county and local laws, ordinances and/or statutes, including any rules or regulations established by any applicable regulatory agency or board.

18. Further Assurances. Each party to this Agreement, upon the request of any other party to this Agreement, will execute, acknowledge and deliver such further documents or instruments and perform such further acts as may be necessary or proper to carry out more effectively the purpose of this Agreement.

19. Assignment. This Agreement or any part hereof may not be transferred, conveyed or assigned by Licensee without prior written consent of Licensor.

20. Relationship of the Parties. The parties are acting herein as independent contractors. Nothing herein contained will create or be construed as creating a partnership, joint venture or agency relationship between the parties and no party will have the authority to bind the other in any respect. Licensee will be solely responsible for all wages, income taxes, workers compensation and any other requirements for all personnel it supplies pursuant to this Agreement. Sales taxes, if any, will be the responsibility of the purchaser of the goods or services. Licensee further understands and agrees that Licensor will not be responsible any items or vehicles brought to the Event location by Licensee or any of its employees, agents, representatives or volunteers.

21. Successors and Assigns. All of the terms of this Agreement will apply to, be binding upon and inure to the benefit of the parties hereto, their successors, assigns, heirs and legal representatives, and any other person claiming by, through or under them.

22. Entire Agreement and Modification. The Agreement contains the entire agreement between the parties relating to the subject matter hereof and all prior agreements relative hereto which

are not contained herein are terminated. This Agreement may not be amended, revised, or terminated orally but only by a written instrument executed by the party against which enforcement of the amendment, revision or termination is asserted.

23. Applicable Law. This Agreement will be governed by and construed according to the laws of the State of Mississippi, which are, from time to time, in effect.
24. Force Majeure. The failure of either party hereto to comply with the terms and conditions hereof because of an act of God, strike, labor troubles, war, fire, earthquake, act of public enemies, action of federal, state or local governmental authorities or for any reason beyond the reasonable control of such party will not be deemed breach of this contract.
25. Notices. All notices, requests, demands and other communications under this Agreement will be in writing and will be deemed to have been given if hand delivered or mailed, certified mail, return receipt requested, to the parties at the addresses set forth in the Agreement. All notices delivered by hand shall be effective upon delivery and all notices mailed certified mail, return receipt requested, shall be effective when mailed.
26. No Waiver of Rights. If either party fails to enforce any of the provisions of this Agreement or any rights or fails to exercise any election provided in this Agreement, it will not be considered a waiver of those provisions, rights or elections or in any way affect the validity of this Agreement. The failure of either party to exercise any of these provisions, rights or elections will not preclude or prejudice such party from later enforcing or exercising the same or any other provision, right or election which it may have under this Agreement.
27. Invalidity. If any term, provision, covenant or condition of the Agreement is held by a court of competent jurisdiction to be invalid, void or unenforceable, the remainder of this Agreement will remain in full force and effect and will in no way be affected, impaired or invalidated.
28. Headings. Headings are not part of this Agreement but are only for Convenience.
29. Counterparts. This Agreement may be executed in two or more counterparts, each of which shall be deemed an original, but all of which together shall constitute one and the same instrument.

AGREED and ACCEPTED as of the date first above written.

City of Southaven

By:

Name:

Title:



Darren Musselwhite
Mayor

Event Concessions, Inc.

By:

Name:

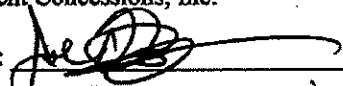
Title:

Joe O'Brien
President

**MISSISSIPPI AMBULANCE ALLIANCE
MEDICAID SUPPLEMENTAL PAYMENT PROGRAM SUPPORT AGREEMENT**

This Medicaid Supplemental Payment Program Support Agreement (“**Agreement**”) is entered into on the dates indicated below each signature and effective on the last of those dates (“**Effective Date**”) by and between the Mississippi Ambulance Alliance (“**MAA**”) and the undersigned person or entity (“**Participant**”), individually and on behalf of one or more EMS providers as hereinafter provided (“**Participating Providers**”).

WHEREAS, MAA is a Mississippi not-for-profit corporation, the mission of which includes promoting excellence in Emergency Medical Services (“**EMS**”) and mobile health care transportation by working with its Participants and their Participating Providers collaboratively to enhance Medicaid reimbursement for EMS and mobile health care transportation; and

WHEREAS, the current level of Medicaid payments to EMS providers in Mississippi is substantially below the costs incurred by Mississippi EMS providers in rendering those services; and

WHEREAS, this inadequate Medicaid reimbursement threatens the quality of EMS available to all citizens of Mississippi; and

WHEREAS, MAA has or will engage in a project with the Mississippi Division of Medicaid and the Mississippi State Department of Health (“**MSDH**”) to develop and implement a medical transportation assessment fee program (“**Assessment Fee Program**”) to fund and make supplemental Medicaid payments to certain EMS providers in Mississippi; and

WHEREAS, the Assessment Fee Program will include both the payment by certain EMS providers (other than those owned by governmental entities or volunteer fire departments) of assessments and the receipt by those EMS providers of supplemental Medicaid payments; and

WHEREAS, MAA has and will continue to incur substantial expense in the development and implementation of the Assessment Fee Program; and

WHEREAS, it is essential to the implementation and continued success of the Assessment Fee Program that the Eligible EMS Providers that benefit from that program support the related expenses; and

WHEREAS, this Agreement is required to insure that the expenses of the Assessment Fee Program are properly funded; and

WHEREAS, the undersigned Participant owns, or otherwise has the right to enter into this Agreement on behalf of, certain Eligible EMS Providers listed on Exhibit I.9 (“**Participating Providers**”), all of which are parties to this Agreement.

NOW, THEREFORE, for and in consideration of the mutual promises and conditions contained herein, the parties mutually agree as follows:

I. Definitions

1. “**Assessment Fee**” – The fee charged by the State of Mississippi on Eligible EMS Providers, including Participating Providers, as part of the Assessment Fee Program.
2. “**Assessment Fee Program**” – The program implemented by MSDH under which an Assessment Fee is charged to and paid by Eligible EMS Providers and used to fund Supplemental Medicaid Payments to Eligible EMS Providers, including Participating Providers.
3. “**Assessment Fee Services**” – Those medical transportation and other related services, whether emergency or non-emergency, which are subject to the Assessment Fee.
4. “**Base Payments**” – Any and all payments currently made by MSDH to Eligible EMS Providers, including Participating Providers, for Assessment Fee Services provided by such Eligible EMS Providers to Mississippi Medicaid beneficiaries, which does not include any Medicaid supplemental payments.
5. “**Eligible EMS Providers**” – Those providers of emergency medical services in Mississippi that are subject to the Assessment Fee.
6. “**Medicaid Supplemental Payments**” – Those payments, over and above the Base Payments, made by MSDH as part of the Assessment Fee Program.
7. “**Participant**” – The entity which owns, or otherwise is authorized to execute this Agreement on behalf of, itself and those Participating Providers listed on Schedule I.9. Participant may also be a Participating Provider.
8. “**Participating Provider Contribution**” – The amount, calculated as provided herein, which each Participating Providers agrees to pay to MAA upon implementation of the Assessment Fee Program.
9. “**Participating Providers**” - Those EMS providers represented by Participant, which are bound by the terms of this Agreement, and which are listed on Schedule I.9. Participating Provider may also be the Participant.

II. Obligations of Participant

1. Each Participating Provider agrees to pay to MAA a Participating Provider Contribution, if any, calculated for each calendar quarter as follows:
 - A. The amount of Medicaid supplemental payments paid to Participating Provider in each quarter shall be determined by MAA based on reported payment data from MSDH.
 - B. The amount of the Assessment Fee paid by such Participating Provider in that same quarter shall be determined by MAA based on reported assessment data from MSDH.
 - C. The “**Participating Provider Contribution Threshold**” shall be determined by multiplying the Participant’s Assessment Fee (II.1.B, above) by 1.05.
 - D. The “**Participating Provider Contribution Balance**” shall be determined by subtracting the Participating Provider Contribution Threshold (II.1.C, above) from the Participating Provider’s Medicaid supplemental payments (II.1.A, above).
 - E. If the Participating Provider Contribution Balance is positive, the Participant will remit to the MAA, as hereinafter provided, a Participating Provider Contribution in an amount equal to eighteen percent (18%) of such Participant’s Participant Contribution Balance, provided that the Board of Directors of MAA may prospectively set the amount of the Participating Provider Contribution below eighteen percent (18%) for all Participants.
 - F. In any quarter that the Participating Provider Contribution Balance is negative, no Participating Provider Contribution is due.
2. Examples – The following, provided solely for clarification, reflect examples of the calculation in II.1, above.

(continued on next page)

A. Alpha Ambulance Service –

Assessment Fee	\$1,000	
Supplemental Payments	\$3,000	
Participating Provider Contribution Threshold	\$1,050	(1.05 X Assessment Fee)
Participating Provider Contribution Balance	\$1,950	(supplemental payment – Participating Provider Contribution Threshold)
Participating Provider Contribution to MAA	\$351	Participating Provider Contribution Balance X 18%

B. Beta Ambulance Service

Assessment Fee	\$1,000	
Supplemental Payments	\$800	
Participating Provider Contribution Threshold	\$1,050	(1.05 X Assessment Fee)
Participating Provider Contribution Balance	(\$250)	(supplemental payment – Participating Provider Contribution Threshold)
Participating Provider Contribution to MAA	\$0	Participating Provider Contribution Balance X 18%

3. Any Participating Provider Contribution due from Participating Provider to MAA under II.1.F, above, will be paid to MAA as provided in Exhibit II.3, attached hereto and made a part hereof, no later than ten (10) days after receipt of notice from MAA of the amount due. Exhibit II.3 may be updated from time to time by the mutual consent of the parties. If any Participating Provider Contribution is not paid within ten (10) days, Participating Provider shall additionally owe to MAA a late payment penalty of five percent (5%) of the amount due and owing.
4. In the event that it is determined, following such payment of the Participating Provider Contribution, that a greater Participating Provider Contribution is due, Participating Provider shall remit the unpaid balance within ten (10) days of notice thereof.
5. Should it become necessary for MAA to engage the services of an attorney to collect the Participating Provider Contribution, MAA shall be reimbursed by Participating Provider, in addition to the Participating Provider Contribution and any late payment penalties due, reasonable attorney's fees incurred by MAA in such collection.

III. Obligations of MAA

1. Participating Provider Contribution Management. With respect to each calendar quarter following implementation of Medicaid supplemental payments (or portion thereof):
 - A. MAA will work with MSDH to determine all Assessments Fees paid by Participating Providers and Medicaid supplemental payments paid to Participating Providers.
 - B. Within ten (10) days of receipt of the above information, MAA will notify all Participating Provider of any Participating Provider Contributions due under II.1.E, above.
 - C. MAA will use commercially reasonable efforts to promptly collect from Participating Providers the Participating Provider Contributions required under II.1.E, above.
2. Program Obligations.
 - A. Upon final approval by the Centers for Medicare & Medicaid Services (CMS) of the Assessment Fee Program, MAA will monitor and work with MSDH to implement and maximize the benefits of the new Assessment Fee Program to Participating Provider.
 - B. MAA shall provide education specific to data submission requirements for Assessment Fees and assistance with compliance.
 - C. MAA will continue to work with MSDH to identify and implement additional opportunities that will enhance reimbursement for services provided by Participating Provider.
 - D. MAA will be solely responsible for all costs associated with the development and implementation of the Assessment Fee Program, including engaging professionals such as attorneys, certified public accountants, policy experts, and others as necessary to accomplish the objectives described herein.
 - E. MAA shall provide for an independent third party review of compliance with the terms of this Agreement. The report shall be made available to Participating Providers.

IV. Term and Termination

1. This Agreement is effective on the Effective Date stated above, and shall continue for an initial term of three (3) years from the Effective Date. Notwithstanding the foregoing, the

three (3) year term of this Agreement shall automatically renew for successive three (3) year terms, unless either party provides written notice to the other party of its intention not to extend this Agreement beyond the end of the then current three-year term at least thirty (30) days prior to the expiration of such current term.

2. This Agreement may be terminated as follows:

- A. By either party immediately upon written notice to the other in the event that the Assessment Fee Program is not approved, or is materially modified by CMS, or is permanently discontinued by MSDH.
- B. By either party, in the event of a change in any applicable law or regulation, or in the controlling interpretation of any applicable law or regulation, which renders any material obligation of either party invalid, unenforceable or illegal, upon thirty (30) days written notice to the other, provided that the parties agree during the thirty (30) day period to negotiate in good faith on an amendment to cure the issue which is the basis of the notice.
- C. In the event of a material default by either party, upon thirty (30) days written notice by the non-defaulting party to the defaulting party, unless the defaulting party has cured the default to the satisfaction of the other party prior to the expiration of the thirty day notice period

V. Miscellaneous

- 1. Authority. Participant represents and warrants that it has the authority to enter into this Agreement and to bind hereunder and hereto the Participating Provider(s) listed on Schedule I.9. Participant further represents and warrants that entering into this Agreement, and that Participating Provider(s) entering into this Agreement, is not prohibited by and does not violate any applicable obligation, whether legal, contractual or otherwise, of Participant or any of the Participating Providers.
- 2. Confidentiality. To the extent authorized by the Mississippi Public Records Act, this Agreement and the attachments are confidential documents provided, however, that Participant, Participating Providers, and MAA may share these documents with any of their owners, directors, employees or agents. To the extent authorized by the Mississippi Public Records Act, both parties agree to hold these documents confidential and will not disclose paper or electronic copies to any outside parties without express written permission from the other party. MAA agrees not to share the specific amounts being received or being paid by the Participating Provider under this Agreement with any third

party (except for any Participant and Participating Provider participating in the Assessment Fee Program and all Participants and Participating Providers will be treated equally and receive the same information) without the prior written consent of the Participant. In addition, MAA agrees not to use any information about the Participating Providers and their participation in the Assessment Fee Program for any purpose other than the implementation of such methodology.

3. Publicity. No party to this Agreement shall originate any publicity, news release or other public announcement, about, related to, or arising out of this Agreement, without the prior written consent of the other party.
4. Notices. (a) Any notice shall be deemed to have been received on the date which is: (i) 3 business days after the date of proper posting, if sent by certified U.S. mail or by Express U.S. mail or the date delivery is acknowledged by a recognized overnight courier; or (ii) the date on which sent, if sent by facsimile transmission, with confirmation and with the original to be sent by certified U.S. mail or recognized overnight courier, addressed as provided on Exhibit V.3, attached hereto. Any party hereto may change its address specified for notices herein by designating a new address by notice to the other party.
5. Assignment. This Agreement shall not be assignable by any of the parties hereto without the written consent of the other party.
6. Entire Agreement. The parties hereto acknowledge that this Agreement, including the Appendices and documents incorporated by reference, sets forth the entire agreement and understanding of the parties hereto as to the subject matter hereof, and shall not be subject to any change of modification except by the execution of a written instrument subscribed to by the parties hereto. This Agreement shall supersede all previous communications, representations or understandings, either oral or written, between the parties relating to the subject matter hereof.
7. No Third Party Beneficiary. Nothing in this Agreement, express or implied, is intended to confer on any person other than the parties hereto, or their respective successors, assigns and legal representatives any rights, remedies, obligations or liabilities under or by reason of this Agreement.
8. Counterparts. This Agreement may be executed in two or more counterparts, each of which shall be deemed an original, but all of which together shall constitute one and the same instrument.

[Signatures on following pages]

THUS DONE AND SIGNED, Mississippi Ambulance Alliance has executed this Medicaid Supplemental Payment Program Support Agreement effective as the Effective Date stated above.

MAA:

MISSISSIPPI AMBULANCE ALLIANCE

By: _____
Name: _____
Title: _____
Date: _____

THUS DONE AND SIGNED, Participant has executed this Medicaid Supplemental Payment Program Support Agreement effective as the Effective Date stated above.

PARTICIPANT:

By: _____

Name: _____

Title: _____

Date: _____

Schedule I.9
EMS Providers that are Parties to this Agreement (“Participating Providers”)

Participating Provider	Medicaid Provider Number

Exhibit II.3
Instructions for Participating Provider Contribution Payments
(complete one for each Participating Provider listed on Schedule I.9)

I. Bank Account Information:

Participating Provider's Name: _____

Account Name: _____

Bank: _____

Account Number: _____

Routing Number: _____

II. Initial one of the following:

_____ Mississippi Medicaid payments to the Participating Provider named above are made to this account and not swept or otherwise transferred into another account.

_____ Mississippi Medicaid payments to the Participating Provider named above are made to another account but swept or otherwise transferred into this account.

III. Disclosures: Describe any lien or other restriction or agreement that would prevent the Mississippi Ambulance Alliance from drafting this account as provided in the Medicaid Supplemental Payment Program Support Agreement:

IV. Agreement: The above named Participating Provider hereby authorizes the Mississippi Ambulance Alliance to draft this account according to the terms of the Medicaid Supplemental Payment Program Support Agreement entered into between the Participant, Participating Provider and the Mississippi Ambulance Alliance, and the terms of the agreement relating to such drafting attached hereto.

(signature on following page)

PARTICIPATING PROVIDER: _____

BY: _____

Name: _____

Title: _____

Date: _____

**Exhibit V.3
Notice Information**

(complete one for each Participating Provider listed on Schedule I.9)

If to MAA:

With a copy to:

If to Participating Provider:

With a copy to:

CONFIDENTIALITY AND NONDISCLOSURE AGREEMENT

THIS Confidentiality and Nondisclosure Agreement (“**Agreement**”) is effective on the ____ day of December 2022 (“**Effective Date**”), and is made and entered into by and between the City of Southaven (the “**Company**”), the Mississippi Ambulance Alliance (“**MAA**”), MAA’s contractor ITG Strategies, LLC (“**ITG**”), and ITG’s subcontractor, Breazeale, Sachse & Wilson, LLP (“**BSW**”). ITG and BSW are collectively the “**Consultants**”. Company, MAA, ITG and BSW are each sometimes referred to as “**Party**.”

WHEREAS, MAA is an association for providers of emergency medical transportation services in Mississippi, and Company is a member of MAA;

WHEREAS, MAA has contracted with ITG to assist it and its members in the development and implementation (the “**Services**”) of a Medicaid supplemental payment program for emergency medical services in Mississippi (the “**Project**”), and ITG has subcontracted with BSW to assist it in providing the Services;

WHEREAS, in providing the Services, Consultants will gather and analyze, or have direct or indirect access to, information from Company and other MAA members (“**Disclosing Party**”) which may include, but is not limited to, financial statements, revenue data, expense data, pricing structures, other financial information, and other data and information, any and all of which may be conveyed orally, electronically, or in written, graphic or other form, all of which are hereinafter collectively referred to as the “**Confidential Information**,” and

WHEREAS, the Parties have agreed that the confidentiality of the Confidential Information shall be maintained, and desire to enter into this Agreement to document the terms thereof.

NOW THEREFORE, in consideration of the mutual covenants and undertakings set forth herein, the adequacy and sufficiency of which each Party hereby acknowledges, the Parties, intending to be legally and contractually bound, do hereby covenant, contract and agree as follows:

1. **Confidentiality**. Each Consultant hereby contracts and agrees that at all times, except as otherwise specifically permitted by this Agreement, it shall not, without the prior written consent of the Disclosing Party, disclose, or permit the disclosure of, either directly or indirectly, or intentionally or unintentionally, any Confidential Information of the Disclosing Party to anyone other than the Consultant’s officers, directors, employees, and contractors (who shall agree to comply with this Agreement as a condition of having access to any Confidential Information), and then solely for the purpose of and only to the extent necessary to provide the Services in connection with the Project. Except as required by Miss. Code Ann. § 25-61-9, each Party agrees to take whatever measures are necessary to protect the Confidential Information from disclosure other than as specifically permitted by this Agreement. Except as required by Miss. Code Ann. § 25-61-9, the Parties further acknowledge that the Confidential Information described herein may contain proprietary and trade secret information.
2. **Use of Confidential Information**. Each Consultant hereby contracts and agrees that it shall not, without the prior written consent of the Disclosing Party:

- a. use the Confidential Information of a Disclosing Party for any purpose other than to provide the Services in connection with the Project;
 - b. duplicate, in whole or in part, any Confidential Information of a Disclosing Party except to the extent necessary for the Consultant to provide the Services in connection with the Project; or
 - c. use the Confidential Information directly or indirectly, intentionally or unintentionally, for its own benefit, or use or facilitate the use of the Confidential Information, directly or indirectly, or intentionally or unintentionally, for the benefit of any other person or entity.
3. Destruction or Return of Confidential Information. Consultants agree to destroy or return all Confidential Information, and all copies and other reproductions thereof, to the delivering Party upon the request of the delivering Party.
4. Exclusions. The following information shall not be deemed to be Confidential Information for purposes of this Agreement, and shall not be governed by the provisions of this Agreement:
- a. any information that was readily available to the general public prior to the time of disclosure;
 - b. any information that became readily available to the general public after the time of disclosure other than as a complete or partial result of any breach of this Agreement; and
 - c. any information acquired by Consultants from sources entirely unrelated to the Disclosing Party and its employees, officers, directors, owners, legal counsel, financial advisors, agents and representatives, and which sources had no obligation of confidentiality or secrecy to a Party.
5. Remedies. Consultants hereby acknowledge and agree that the disclosure or use of Confidential Information in violation of this Agreement would result in severe and irreparable harm. Accordingly, Consultants hereby contract and agree that, in the event of any actual or threatened breach or violation of any of the terms of this Agreement, Disclosing Party or any other Party may obtain from any court of competent jurisdiction both preliminary and permanent injunctive relief prohibiting such disclosure and/or use, which rights and remedies shall be cumulative and in addition to any and all other legal and equitable remedies to which the potentially injured Party may be entitled under the law. Consultants acknowledge and agree that they will be liable for any breach of this Agreement by any of their officers, directors, shareholders, employees, attorneys, accountants, financial advisors, and other agents.
6. Miscellaneous. This Agreement: (a) contains the entire understanding between the Parties regarding the subject matter hereof and supersedes any and all previous agreements and understandings of the Parties regarding the subject matter hereof, and (b) may not be altered, amended, changed or modified, except in writing and signed by all of the Parties. This Agreement shall be severable, and the invalidity of any portion of this Agreement or any section

thereof shall not impair or invalidate the remainder of this Agreement of the remainder of such section.

7. Governing Law. This Agreement shall be governed by and shall be interpreted and construed under and in accordance with, the laws of the State of Mississippi.
8. Term and Survival. Notwithstanding anything to the contrary, each and all of the restrictions and obligations of this Agreement shall survive any expiration or termination of this Agreement, and shall continue to be binding on each Party, and its legal representatives, successors and assigns.

[Signatures on following page]

MISSISSIPPI AMBULANCE ALLIANCE

By: _____

Name/ Title: _____

Date: _____

CITY OF SOUTHAVEN

By: _____

Name/Title: _____

Date: _____

ITG STRATEGIES, LLC

By: _____

Name/ Title: _____

Date: _____

BREAZEALE, SACHSE, & WILSON, LLP

By: _____

Name/ Title: _____

Date: _____



WATKINS, WARD and STAFFORD
Professional Limited Liability Company
Certified Public Accountants

3205 North Church Ave. P.O. Box 270 Louisville, MS 39339
Phone (662) 773-7841 Fax (662) 773-9236

James L. Stafford, CPA
Harry W. Stevens, CPA
S. Keith Winfield, CPA
William B. Stagers, CPA
Michael W. McCully, CPA
R. Steve Sinclair, CPA
Marsha L. McDonald, CPA
Wanda S. Holley, CPA
Robin Y. McCormick, CPA/PFS
J. Raudy Scrivner, CPA
Kimberly S. Caskey, CPA
Susan M. Lummus, CPA

Stephen D. Flake, CPA
John N. Russell, CPA
Anita L. Goodrum, CPA
Ricky D. Allen, CPA
Jason D. Brooks, CPA
Robert E. Cordle, Jr., CPA
Perry C. Rackley, Jr., CPA
Jerry L. Gammel, CPA
Michael C. Knox, CPA
Clifford P. Stewart, CPA
Edward A. Maxwell, CPA

December 20, 2022

To Honorable Darren Musselwhite and the Southaven, Mississippi Board of Aldermen
City of Southaven
8710 Northwest Avenue
Southaven, MS 38671

We are pleased to confirm our understanding of the services we are to provide for City of Southaven< Mississippi for the year ended September 30, 2022.

Audit Scope and Objectives

We will audit the financial statements of the governmental activities, the business-type activities, each major fund, and the aggregate remaining fund information, including the disclosures, which collectively comprise the basic financial statements, of Southaven, Mississippi as of and for the year ended September 30, 2022. Accounting standards generally accepted in the United States of America (GAAP) provide for certain required supplementary information (RSI), such as management's discussion and analysis (MD&A), to supplement City of Southaven, Mississippi's basic financial statements. Such information, although not a part of the basic financial statements, is required by the Governmental Accounting Standards Board who considers it to be an essential part of financial reporting for placing the basic financial statements in an appropriate operational, economic, or historical context. As part of our engagement, we will apply certain limited procedures to City of Southaven, Mississippi's RSI in accordance with auditing standards generally accepted in the United States of America (GAAS). These limited procedures will consist of inquiries of management regarding the methods of preparing the information and comparing the information for consistency with management's responses to our inquiries, the basic financial statements, and other knowledge we obtained during our audit of the basic financial statements. We will not express an opinion or provide any assurance on the information because the limited procedures do not provide us with sufficient appropriate evidence to express an opinion or provide any assurance. The following RSI is required by GAAP and will be subjected to certain limited procedures, but will not be audited:

- 1) Management's Discussion and Analysis.
- 2) Budgetary Comparison Schedules
- 3) Schedule of the City's Proportionate Share of the Net Pension Liability (PERS)
- 4) Schedule of the City's Contributions (PERS)
- 5) Schedule of Changes in the Total OPEB Liability

We have also been engaged to report on supplementary information other than RSI that accompanies City of Southaven, Mississippi's financial statements. We will subject the following supplementary information to the auditing procedures applied in our audit of the financial statements and certain additional procedures, including comparing and reconciling such information directly to the underlying accounting and other records used to prepare the financial statements or to the financial statements themselves, and other additional procedures in accordance with GAAS, and we will provide an opinion on it in relation to the financial statements as a whole in a separate written report accompanying our auditor's report on the financial statements OR in a report combined with our auditor's report on the financial statements.

1) Schedules of Revenues, Expenditures and Changes in Fund Balance – Budgetary Basis – Other Governmental Funds other than General Fund and Special Revenue Funds and Proprietary Funds

In connection with our audit of the basic financial statements, we will read the following other information and consider whether a material inconsistency exists between the other information and the basic financial statements, or the other information otherwise appears to be materially misstated. If, based on the work performed, we conclude that an uncorrected material misstatement of the other information exists, we are required to describe it in our report.

- 1) Schedule of Surety Bonds for Municipal Officials
- 2) Schedule of Expenditures of Federal Awards

The objectives of our audit are to obtain reasonable assurance about whether the financial statements as a whole are free from material misstatement, whether due to fraud or error, and issue an auditor's report that includes our opinions about whether your financial statements are fairly presented, in all material respects, in conformity with GAAP, and report on the fairness of the supplementary information referred to in the second paragraph when considered in relation to the financial statements as a whole. Reasonable assurance is a high level of assurance but is not absolute assurance and therefore is not a guarantee that an audit conducted in accordance with GAAS and *Government Auditing Standards* will always detect a material misstatement when it exists. Misstatements, including omissions, can arise from fraud or error and are considered material if there is a substantial likelihood that, individually or in the aggregate, they would influence the judgment of a reasonable user made based on the financial statements. The objectives also include reporting on:

- Internal control over financial reporting and compliance with provisions of laws, regulations, contracts, and award agreements, noncompliance with which could have a material effect on the financial statements in accordance with *Government Auditing Standards*.
- Internal control over compliance related to major programs and an opinion (or disclaimer of opinion) on compliance with federal statutes, regulations, and the terms and conditions of federal awards that could have a direct and material effect on each major program in accordance with the Single Audit Act Amendments of 1996 and Title 2 U.S. Code of Federal Regulations (CFR) Part 200, *Uniform Administrative Requirements, Cost Principles, and Audit Requirements for Federal Awards* (Uniform Guidance).

Auditor's Responsibilities for the Audit of the Financial Statements and Single Audit

We will conduct our audit in accordance with GAAS; the standards for financial audits contained in *Government Auditing Standards*, issued by the Comptroller General of the United States; the Single Audit Act Amendments of 1996; and the provisions of the Uniform Guidance, and will include tests of accounting records, a determination of major program(s) in accordance with Uniform Guidance, and other procedures we consider necessary to enable us to express such opinions. As part of an audit in accordance with GAAS and *Government Auditing Standards*, we exercise professional judgment and maintain professional skepticism throughout the audit.

We will evaluate the appropriateness of accounting policies used and the reasonableness of significant accounting estimates made by management. We will also evaluate the overall presentation of the financial statements, including the disclosures, and determine whether the financial statements represent the underlying transactions and events in a manner that achieves fair presentation. We will plan and perform the audit to obtain reasonable assurance about whether the financial statements are free of material misstatement, whether from (1) errors, (2) fraudulent financial reporting, (3) misappropriation of assets, or (4) violations of laws or governmental regulations that are attributable to the government or to acts by management or employees acting on behalf of the government. Because the determination of waste and abuse is subjective, *Government Auditing Standards* do not expect auditors to perform specific procedures to detect waste or abuse in financial audits nor do they expect auditors to provide reasonable assurance of detecting waste or abuse.

Because of the inherent limitations of an audit, combined with the inherent limitations of internal control, and because we will not perform a detailed examination of all transactions, there is an unavoidable risk that some material misstatements or noncompliance may not be detected by us, even though the audit is properly planned and performed in accordance with GAAS and *Government Auditing Standards*. In addition, an audit is not

designed to detect immaterial misstatements or violations of laws or governmental regulations that do not have a direct and material effect on the financial statements or on major programs. However, we will inform the appropriate level of management of any material errors, any fraudulent financial reporting, or misappropriation of assets that come to our attention. We will also inform the appropriate level of management of any violations of laws or governmental regulations that come to our attention, unless clearly inconsequential. We will include such matters in the reports required for a Single Audit. Our responsibility as auditors is limited to the period covered by our audit and does not extend to any later periods for which we are not engaged as auditors.

We will also conclude, based on the audit evidence obtained, whether there are conditions or events, considered in the aggregate, that raise substantial doubt about the government's ability to continue as a going concern for a reasonable period of time.

Our procedures will include tests of documentary evidence supporting the transactions recorded in the accounts, tests of the physical existence of inventories, and direct confirmation of receivables and certain assets and liabilities by correspondence with selected individuals, funding sources, creditors, and financial institutions. We will also request written representations from your attorneys as part of the engagement.

We have identified the following significant risk(s) of material misstatement as part of our audit planning:

- Management override of controls

We may, from time to time and depending on the circumstances, use third-party service providers in serving your account. We may share confidential information about you with these service providers but remain committed to maintaining the confidentiality and security of your information. Accordingly, we maintain internal policies, procedures, and safeguards to protect the confidentiality of your personal information. In addition, we will secure confidentiality agreements with all service providers to maintain the confidentiality of your information and we will take reasonable precautions to determine that they have appropriate procedures in place to prevent the unauthorized release of your confidential information to others. In the event that we are unable to secure an appropriate confidentiality agreement, you will be asked to provide your consent prior to the sharing of your confidential information with the third-party service provider. Furthermore, we will remain responsible for the work provided by any such third-party service providers.

Our audit of financial statements does not relieve you of your responsibilities.

Audit Procedures—Internal Control

We will obtain an understanding of the government and its environment, including internal control relevant to the audit, sufficient to identify and assess the risks of material misstatement of the financial statements, whether due to error or fraud, and to design and perform audit procedures responsive to those risks and obtain evidence that is sufficient and appropriate to provide a basis for our opinions. The risk of not detecting a material misstatement resulting from fraud is higher than for one resulting from error, as fraud may involve collusion, forgery, intentional omissions, misrepresentation, or the override of internal control. Tests of controls may be performed to test the effectiveness of certain controls that we consider relevant to preventing and detecting errors and fraud that are material to the financial statements and to preventing and detecting misstatements resulting from illegal acts and other noncompliance matters that have a direct and material effect on the financial statements. Our tests, if performed, will be less in scope than would be necessary to render an opinion on internal control and, accordingly, no opinion will be expressed in our report on internal control issued pursuant to *Government Auditing Standards*.

As required by the Uniform Guidance, we will perform tests of controls over compliance to evaluate the effectiveness of the design and operation of controls that we consider relevant to preventing or detecting material noncompliance with compliance requirements applicable to each major federal award program. However, our tests will be less in scope than would be necessary to render an opinion on those controls and, accordingly, no opinion will be expressed in our report on internal control issued pursuant to the Uniform Guidance.

An audit is not designed to provide assurance on internal control or to identify significant deficiencies or material weaknesses. Accordingly, we will express no such opinion. However, during the audit, we will communicate to management and those charged with governance internal control related matters that are required to be communicated under AICPA professional standards, *Government Auditing Standards*, and the Uniform Guidance.

Audit Procedures—Compliance

As part of obtaining reasonable assurance about whether the financial statements are free of material misstatement, we will perform tests of City of Southaven, Mississippi's compliance with provisions of applicable laws, regulations, contracts, and agreements, including grant agreements. However, the objective of those procedures will not be to provide an opinion on overall compliance, and we will not express such an opinion in our report on compliance issued pursuant to *Government Auditing Standards*.

The Uniform Guidance requires that we also plan and perform the audit to obtain reasonable assurance about whether the auditee has complied with federal statutes, regulations, and the terms and conditions of federal awards applicable to major programs. Our procedures will consist of tests of transactions and other applicable procedures described in the *OMB Compliance Supplement* for the types of compliance requirements that could have a direct and material effect on each of City of Southaven, Mississippi's major programs. For federal programs that are included in the Compliance Supplement, our compliance and internal control procedures will relate to the compliance requirements that the Compliance Supplement identifies as being subject to audit. The purpose of these procedures will be to express an opinion on City of Southaven Mississippi's compliance with requirements applicable to each of its major programs in our report on compliance issued pursuant to the Uniform Guidance.

Other Services

We will also assist in preparing the financial statements, schedule of expenditures of federal awards, and related notes of [Name of Governmental Unit] in conformity with accounting principles generally accepted in the United States of America and the Uniform Guidance based on information provided by you. These nonaudit services do not constitute an audit under *Government Auditing Standards* and such services will not be conducted in accordance with *Government Auditing Standards*. We will perform the services in accordance with applicable professional standards. The other services are limited to the financial statements, schedule of expenditures of federal awards, and related notes services previously defined. We, in our sole professional judgment, reserve the right to refuse to perform any procedure or take any action that could be construed as assuming management responsibilities.

You agree to assume all management responsibilities for the financial statements, schedule of expenditures of federal awards, and related notes, and any other nonaudit services we provide. You will be required to acknowledge in the management representation letter our assistance with preparation of the financial statements, the schedule of expenditures of federal awards, and related notes and that you have reviewed and approved the financial statements, the schedule of expenditures of federal awards, and related notes prior to their issuance and have accepted responsibility for them. Further, you agree to oversee the nonaudit services by designating an individual, preferably from senior management, with suitable skill, knowledge, or experience; evaluate the adequacy and results of those services; and accept responsibility for them.

Responsibilities of Management for the Financial Statements and Single Audit

Our audit will be conducted on the basis that you acknowledge and understand your responsibility for (1) designing, implementing, establishing, and maintaining effective internal controls relevant to the preparation and fair presentation of financial statements that are free from material misstatement, whether due to fraud or error, including internal controls over federal awards, and for evaluating and monitoring ongoing activities to help ensure that appropriate goals and objectives are met; (2) following laws and regulations; (3) ensuring that there is reasonable assurance that government programs are administered in compliance with compliance requirements; and (4) ensuring that management and financial information is reliable and properly reported. Management is also responsible for implementing systems designed to achieve compliance with applicable laws, regulations, contracts, and grant agreements. You are also responsible for the selection and application of accounting principles; for the preparation and fair presentation of the financial statements, schedule of expenditures of federal awards, and all accompanying information in conformity with accounting principles generally accepted in the United States of America; and for compliance with applicable laws and regulations (including federal statutes), rules, and the provisions of contracts and grant agreements (including award agreements). Your responsibilities also include identifying significant contractor relationships in which the contractor has responsibility for program compliance and for the accuracy and completeness of that information.

You are also responsible for making drafts of financial statements, schedule of expenditures of federal awards, all financial records, and related information available to us and for the accuracy and completeness of that

information (including information from outside of the general and subsidiary ledgers). You are also responsible for providing us with (1) access to all information of which you are aware that is relevant to the preparation and fair presentation of the financial statements, such as records, documentation, identification of all related parties and all related-party relationships and transactions, and other matters; (2) access to personnel, accounts, books, records, supporting documentation, and other information as needed to perform an audit under the Uniform Guidance; (3) additional information that we may request for the purpose of the audit; and (4) unrestricted access to persons within the government from whom we determine it necessary to obtain audit evidence. At the conclusion of our audit, we will require certain written representations from you about the financial statements; schedule of expenditures of federal awards; federal award programs; compliance with laws, regulations, contracts, and grant agreements; and related matters.

Your responsibilities include adjusting the financial statements to correct material misstatements and confirming to us in the management representation letter that the effects of any uncorrected misstatements aggregated by us during the current engagement and pertaining to the latest period presented are immaterial, both individually and in the aggregate, to the financial statements of each opinion unit taken as a whole.

You are responsible for the design and implementation of programs and controls to prevent and detect fraud, and for informing us about all known or suspected fraud affecting the government involving (1) management, (2) employees who have significant roles in internal control, and (3) others where the fraud could have a material effect on the financial statements. Your responsibilities include informing us of your knowledge of any allegations of fraud or suspected fraud affecting the government received in communications from employees, former employees, grantors, regulators, or others. In addition, you are responsible for identifying and ensuring that the government complies with applicable laws, regulations, contracts, agreements, and grants. You are also responsible for taking timely and appropriate steps to remedy fraud and noncompliance with provisions of laws, regulations, contracts, and grant agreements that we report. Additionally, as required by the Uniform Guidance, it is management's responsibility to evaluate and monitor noncompliance with federal statutes, regulations, and the terms and conditions of federal awards; take prompt action when instances of noncompliance are identified including noncompliance identified in audit findings; promptly follow up and take corrective action on reported audit findings; and prepare a summary schedule of prior audit findings and a separate corrective action plan. The summary schedule of prior audit findings should be available for our review on February 28, 2023.

You are responsible for identifying all federal awards received and understanding and complying with the compliance requirements and for the preparation of the schedule of expenditures of federal awards (including notes and noncash assistance received, and COVID-19-related concepts, such as lost revenues, if applicable) in conformity with the Uniform Guidance. You agree to include our report on the schedule of expenditures of federal awards in any document that contains, and indicates that we have reported on, the schedule of expenditures of federal awards. You also agree to [include the audited financial statements with any presentation of the schedule of expenditures of federal awards that includes our report thereon OR make the audited financial statements readily available to intended users of the schedule of expenditures of federal awards no later than the date the schedule of expenditures of federal awards is issued with our report thereon]. Your responsibilities include acknowledging to us in the written representation letter that (1) you are responsible for presentation of the schedule of expenditures of federal awards in accordance with the Uniform Guidance; (2) you believe the schedule of expenditures of federal awards, including its form and content, is stated fairly in accordance with the Uniform Guidance; (3) the methods of measurement or presentation have not changed from those used in the prior period (or, if they have changed, the reasons for such changes); and (4) you have disclosed to us any significant assumptions or interpretations underlying the measurement or presentation of the schedule of expenditures of federal awards.

You are also responsible for the preparation of the other supplementary information, which we have been engaged to report on, in conformity with U.S. generally accepted accounting principles (GAAP). You agree to include our report on the supplementary information in any document that contains, and indicates that we have reported on, the supplementary information. You also agree to [include the audited financial statements with any presentation of the supplementary information that includes our report thereon OR make the audited financial statements readily available to users of the supplementary information no later than the date the supplementary information is issued with our report thereon]. Your responsibilities include acknowledging to us in the written representation letter that (1) you are responsible for presentation of the supplementary information in accordance with GAAP; (2) you believe the supplementary information, including its form and content, is fairly presented in accordance with GAAP; (3) the methods of measurement or presentation have not changed from those used in the prior period (or, if they have changed, the reasons for such changes); and (4) you have disclosed to us any significant assumptions or interpretations underlying the measurement or presentation of the supplementary information.

Management is responsible for establishing and maintaining a process for tracking the status of audit findings and recommendations. Management is also responsible for identifying and providing report copies of previous financial audits, attestation engagements, performance audits, or other studies related to the objectives discussed in the Audit Scope and Objectives section of this letter. This responsibility includes relaying to us corrective actions taken to address significant findings and recommendations resulting from those audits, attestation engagements, performance audits, or studies. You are also responsible for providing management's views on our current findings, conclusions, and recommendations, as well as your planned corrective actions for the report, and for the timing and format for providing that information.

Engagement Administration, Fees, and Other

We understand that your employees will prepare all cash, accounts receivable, or other confirmations we request and will locate any documents selected by us for testing.

At the conclusion of the engagement, we will complete the appropriate sections of the Data Collection Form that summarizes our audit findings. It is management's responsibility to electronically submit the reporting package (including financial statements, schedule of expenditures of federal awards, summary schedule of prior audit findings, auditor's reports, and corrective action plan) along with the Data Collection Form to the federal audit clearinghouse. We will coordinate with you the electronic submission and certification. The Data Collection Form and the reporting package must be submitted within the earlier of 30 calendar days after receipt of the auditor's reports or nine months after the end of the audit period.

We will provide copies of our reports to the Finance Director of the City of Southaven, Mississippi; however, management is responsible for distribution of the reports and the financial statements. Unless restricted by law or regulation, or containing privileged and confidential information, copies of our reports are to be made available for public inspection.

The audit documentation for this engagement is the property of Watkins, Ward and Stafford, PLLC and constitutes confidential information. However, subject to applicable laws and regulations, audit documentation and appropriate individuals will be made available upon request and in a timely manner to an oversight agency or its designee, a federal agency providing direct or indirect funding, or the U.S. Government Accountability Office for purposes of a quality review of the audit, to resolve audit findings, or to carry out oversight responsibilities. We will notify you of any such request. If requested, access to such audit documentation will be provided under the supervision of Watkins, Ward and Stafford, PLLC personnel. Furthermore, upon request, we may provide copies of selected audit documentation to the aforementioned parties. These parties may intend, or decide, to distribute the copies or information contained therein to others, including other governmental agencies.

The audit documentation for this engagement will be retained for a minimum of five years after the report release date or for any additional period requested by an oversight agency. If we are aware that a federal awarding agency, pass-through entity, or auditee is contesting an audit finding, we will contact the party(ies) contesting the audit finding for guidance prior to destroying the audit documentation.

Stephen D. Flake, CPA is the engagement partner and is responsible for supervising the engagement and signing the reports or authorizing another individual to sign them. We expect to begin our audit on approximately December 27, 2022.

Our fee for these services will be at our standard hourly rates plus out-of-pocket costs (such as report reproduction, word processing, postage, travel, copies, telephone, etc.) except that we agree that our gross fee, including expenses, will not exceed \$65,500. Our standard hourly rates vary according to the degree of responsibility involved and the experience level of the personnel assigned to your audit. The above fee is based on anticipated cooperation from your personnel and the assumption that unexpected circumstances will not be encountered during the engagement. If significant additional time is necessary, we will keep you informed of any problems we encounter and our fees will be adjusted accordingly.

Reporting

We will issue written reports upon completion of our Single Audit. Our reports will be addressed to the Board of Aldermen of City of Southaven, Mississippi. Circumstances may arise in which our report may differ from its expected form and content based on the results of our audit. Depending on the nature of these circumstances, it may be necessary for us to modify our opinions, add a separate section, or add an emphasis-of-matter or other-matter paragraph to our auditor's report, or if necessary, withdraw from this engagement. If our opinions are other

than unmodified, we will discuss the reasons with you in advance. If, for any reason, we are unable to complete the audit or are unable to form or have not formed opinions, we may decline to express opinions or issue reports, or we may withdraw from this engagement.

The *Government Auditing Standards* report on internal control over financial reporting and on compliance and other matters will state that (1) the purpose of the report is solely to describe the scope of testing of internal control and compliance and the results of that testing, and not to provide an opinion on the effectiveness of the entity's internal control or on compliance, and (2) the report is an integral part of an audit performed in accordance with *Government Auditing Standards* in considering the entity's internal control and compliance. The Uniform Guidance report on internal control over compliance will state that the purpose of the report on internal control over compliance is solely to describe the scope of testing of internal control over compliance and the results of that testing based on the requirements of the Uniform Guidance. Both reports will state that the report is not suitable for any other purpose.

We appreciate the opportunity to be of service to City of Southaven, Mississippi and believe this letter accurately summarizes the significant terms of our engagement. If you have any questions, please let us know. If you agree with the terms of our engagement as described in this letter, please sign the attached copy and return it to us.

Very truly yours,

Stephen D. Flake, CPA
Watkins, Ward and Stafford, PLLC

RESPONSE:

This letter correctly sets forth the understanding of City of Southaven, Mississippi.

Management signature: _____

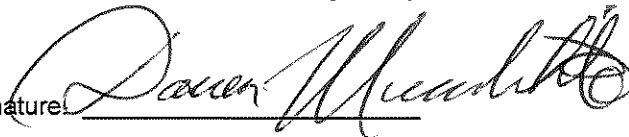

Title: Mayor

Date: December 20, 2022

Governance signature: _____



Title: Alderman At-Large

Date: December 20, 2022



CERTIFIED PUBLIC ACCOUNTANTS
CHATTANOOGA | MEMPHIS

Report on the Firm's System of Quality Control

February 4, 2021

To the Owners of Watkins, Ward & Stafford, PLLC and the Peer Review Committee of the Alabama Society of CPAs.

We have reviewed the system of quality control for the accounting and auditing practice of Watkins, Ward & Stafford, PLLC (the firm) in effect for the year ended April 30, 2020. Our peer review was conducted in accordance with the Standards for Performing and Reporting on Peer Reviews established by the Peer Review Board of the American Institute of Certified Public Accountants (Standards). A summary of the nature, objectives, scope, limitations of, and the procedures performed in a System review as described in the standards may be found at www.aicpa.org/prsummary. The summary also includes an explanation of how engagements identified as not performed or reported in conformity with applicable professional standards, if any, are evaluated by a peer reviewer to determine a peer review rating.

Firm's Responsibility

The firm is responsible for designing a system of quality control and complying with it to provide the firm with reasonable assurance of performing and reporting in conformity with applicable professional standards in all material respects. The firm is also responsible for evaluating actions to promptly remediate engagements deemed as not performed or reported in conformity with professional standards, when appropriate, and for remediating weaknesses in its system of quality control, if any.

Peer Reviewer's Responsibility

Our responsibility is to express an opinion on the design of the system of quality control and the firm's compliance therewith based on our review.

Required Selections and Considerations

Engagements selected for review included engagements performed under *Government Auditing Standards*, including compliance audits under the Single Audit Act, and an audit of an employee benefit plan.

As a part of our peer review, we considered reviews by regulatory entities as communicated by the firm, if applicable, in determining the nature and extent of our procedures.

Opinion

In our opinion, the system of quality control for the accounting and auditing practice of Watkins, Ward & Stafford, PLLC in effect for the year ended April 30, 2020, has been suitably designed and complied with to provide the firm with reasonable assurance of performing and reporting in conformity with applicable professional standards in all material respects. Firms can receive a rating of *pass*, *pass with deficiency*, or *fail*. Watkins, Ward & Stafford, PLLC has received a peer review rating of *pass*.

Henderson Hutcherson
& McCullough, PLLC

1200 Market Street, Chattanooga, TN 37402 | T 423.756.7771 | F 423.265.8125

AN INDEPENDENT MEMBER OF THE BDO ALLIANCE USA

**RESOLUTION OF THE MAYOR AND BOARD OF ALDERMEN
OF THE CITY OF SOUTHAVEN, MISSISSIPPI TO AMEND FY 2022 BUDGET**

The Mayor and Board of Aldermen of the City of Southaven, Mississippi (the “City”), considered the matter of amending the 2023 City Budget.

WHEREAS, pursuant to Miss. Code 21-35-25, the City desires to amend its 2023 budget; and

WHEREAS, the City Governing Authorities, as part of this Amendment, desire to utilize the money restricted for police use from prior period funds to purchase police equipment.

NOW THEREFORE BE IT RESOLVED AS FOLLOWS:

1. The City Board approves the budget amendment as set forth in Exhibit A and authorizes the Mayor or his designee to take any and all actions for such amendment.
2. If required, the City is authorized to publish within two (2) weeks of this action in the same manner as the final adopted budget. This publication shall contain a description of the amendment, the amount of money and funds affected, and a detailed statement explaining the need and purpose of the amendment.
3. The Mayor or his designee are authorized to take all actions to further effectuate the intent of this Resolution.

Following the reading of the foregoing Resolution, Alderman Wheeler made the motion and Alderman Gallagher seconded the motion for its adoption. The Mayor put the question to a roll call vote, and the result was as follows:

Alderman William Jerome	voted: YES
Alderman Kristian Kelly	voted: YES
Alderman George Payne	voted: YES
Alderman Joel Gallagher	voted: YES
Alderman John David Wheeler	voted: YES
Alderman Charlie Hoots	voted: YES
Alderman Raymond Flores	voted: YES

RESOLVED AND DONE, this the 20th day of December, 2022

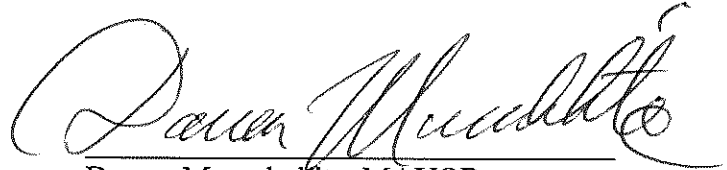
Darren Musselwhite, MAYOR

ATTEST:

Andrea Mullen, CITY CLERK



		Current	Amend	Amended Total
211-630600	VEHICLES	\$ 500,000	\$ 75,490	\$ 575,490
211-630400	MACHINERY & EQUIPMENT	\$ 425,000	\$ 203,323	\$ 628,323
211-661800	CONFISCATED FUNDS-LOCAL	\$ -	\$ 77,449	\$ 77,449
902-620903	FACILITIES RENO/PROJECTS	\$ -	\$ 400,000	\$ 400,000
902-620902	FACILITIES MAINTENANCE	\$ 900,000	\$ (400,000)	\$ 500,000
0010-570102	PRIOR PERIOD FUNDS	\$ (3,665,000)	\$ (356,262)	\$ (4,021,262)

Note: To use money restricted for police use from prior period funds to purchase police equipment.

			\$ -
\$ (1,840,000)	\$ -	\$	(1,840,000)

Make	Ford		
Model	Crown victoria		
Year	2004		
fleet number	5001		
VIN number	2FAFP74W84X142770		

INDEPENDENCE DAY PRODUCTION CONSULTANT AGREEMENT

This Agreement is made this the 22nd day of DEC 2022 by and between **Argo Entertainment, LLC**, a Mississippi Limited Liability Company, and the **City of Southaven**, a municipality located in DeSoto County, Mississippi.

WHEREAS, Argo Entertainment, LLC ("Argo") is in the business of providing entertainment events that include pyrotechnics, music and outdoor entertainment events, and

WHEREAS, the City of Southaven ("City"), pursuant to Chapter 933 House Bill 1618 of 1993 ("Legislation") is authorized to use funds for the promotion of tourism in the City and pursuant to Miss. Code Ann. 17-3-1, the City has determined that its 4th of July Event (the "Event") will help advertise and bring into favorable notice the opportunities, possibilities, and resources of the City, and will advance the moral, financial and other interests of the City and the City is authorized to use funds from the Legislation for the Event and/or funds pursuant to Mississippi Code 17-3-1; and

WHEREAS, the City wishes to contract with Argo for Argo to host the Event, which shall include fireworks, musical entertainment, and other activities as set forth herein, and in consideration of the mutual promises and obligations contained herein, the parties agree as follows:

- 1. The Responsibilities of City.** The City will cooperate with Argo in a reasonable manner. In addition, City will provide the following:
 - 1.1 City will provide Argo reasonable access to certain areas of Snowden Grove Park to be determined by the City Park's Director no later than noon, July 3, 2023 for the purpose of set-up for the Event. City will ensure Argo's use of those areas of Snowden Grove Park, as determined by the City's Park Director, on the day of the Event for the purpose of additional set-up and hosting of the Event. The City's Park Director or his designee, City Police, City Fire Department shall at all times remain in authority and maintain full jurisdiction over Snowden Grove Park.
 - 1.2 City will provide Argo payment of thirty-two thousand and five hundred dollars and 00/100 (\$32,500.00) on or before March 1, 2023, for Argo's producing of the Event in accordance with this Agreement. Argo shall be responsible for all other cost and expense associated with hosting the Event and the City shall have no other costs other than the \$32,500.00 as set forth in this Section 1.2 unless the Event is rescheduled, due to weather or shipping delays, as described in Section 4 of this agreement.
 - 1.3 City will be responsible for all security and traffic control and parking during times of set-up and staging of the Event.
 - 1.4 City will provide fire and ambulance coverage at the Event in a manner appropriate and customary in the industry where pyrotechnics are used.
 - 1.5 City will be responsible for all clean-up after staging of the Event.
 - 1.6 City will cooperate with Argo in regard to the logistics for delivery of fireworks, inflatables, and vendor set-up.

1.7 Argo will provide to City a certificate of insurance naming the City of Southaven as an additional insured with liability coverage, which shall be no less than one million dollars (\$1,000,000.00).

2. The Responsibilities of Argo. Argo will produce the Event and provide all items, vendors, contractors, and entertainment as set forth in this Section 2 at the Snowden Grove Park within the City Limits of Southaven, on July 4, 2023.

- 2.1 Argo will enter into a contract with Pyro Shows whereby Pyro Shows will provide a 20-minute fireworks production. Argo will deliver to City an insurance certificate from Pyro Shows naming Argo and City as additional insureds. Coverage will be no less than ten million dollars (\$10,000,000.00). The contract between Argo and Pyro Shows shall contain a provision providing for the assignment of the contract from Argo to City, in the event, Argo is otherwise unable to perform its responsibilities pursuant to this Agreement.
- 2.2 Upon approval of the City's Park Director, Argo will utilize Event staging already in place at the Snowden Grove Amphitheater.
- 2.3 Argo will provide sound systems and technicians to operate the appropriate sound equipment suitable for the musical acts and entertainment.
- 2.4 Argo will contract with entertainers to appear and perform at the Event and Argo shall be responsible for all costs involved for musical acts and sound equipment or any other costs associated with the entertainers. The consent of City is required prior to Argo contracting with those entertainers for the Event, which names of the entertainers shall be provided to the City by June 1, 2023. No act, performance, exhibition, entertainment, vendor, or sponsorship/promotional media or material shall be given, posted, distributed, or allowed at the Event which is indecent, lewd, obscene, or immoral, including nudity and graphic obscenities. Should any act, performance, exhibition, entertainment, vendor, or sponsorship/promotional media or material, or any part thereof, be deemed by the City to be indecent, lewd, obscene, immoral, or in any manner publicly offensive, the City shall have the authority to stop the Event or to demand the removal of the objectionable subject. The City reserves the right to eject or cause to be ejected from the Event any objectionable person or persons. The City shall not be liable in any way to Argo for the City's actions under this Section.
- 2.5 Argo will be responsible for all Event marketing. Such marketing may include, but may not be limited to, on-line, radio, TV and print. The City shall also maintain the right to market the Event.
- 2.6 Argo will provide other activities, including but not limited to, "moonbounces," inflatables, and items of a similar nature. Argo shall obtain from any company providing moonbounces, inflatables, and the like a certificate of insurance with coverage of no less than one million dollars (\$1,000,000.00) listing both Argo and City as additional insureds. Argo shall provide such certificates of insurance to the City.
- 2.7 Argo will seek and contract for sponsorships for the Event. The revenues will be the property of Argo exclusively and from those revenues, Argo agrees to host the Event described herein. Argo agrees to honor and shall not compete with City sponsorships already in place. The City Park's Director shall approve the actual display and location of display of any sponsorship material at Snowden Grove Park. Argo shall remove any and all displays within twenty four

(24) hours of the Event. If such displays are not removed by Argo, the City shall have the right to remove and dispose of the displays.

2.8 Argo will seek and contract with food vendors for the event. The revenues derived from those vendor contracts will be the property of Argo exclusively.

3. Argo agrees to provide notice to City by March 1, 2023, in the event, it is unable to perform any or all of its responsibilities set forth herein. In the event, Argo is unable to perform any or all of its responsibilities set forth in this Agreement, Argo agrees to assign to City its rights under any of the vendor contracts necessary to host the event. In addition, if Argo is unable to perform and if the City desires to host the Event, Argo shall transfer to City such portion of the sponsorship proceeds as may be necessary to host the Event, including, but not limited to, City's \$32,500 sponsorship payment. If Argo does not provide such notice and in fact does not perform, Argo shall refund the City's sponsorship payment in full and to deal in good faith in regard to its contractual obligations with other vendors and sponsors. In no event, shall the City be liable to any vendor or contractor of Argo for Argo's failure to perform any portion of its contract with such vendor or contractor. Furthermore, the City shall maintain the right to seek any and all other legal remedies against Argo.

4. Argo and City agree that weather or other events outside the control of either party, including, but not limited to shipping delays, may impact the Event, particularly with regard to the firework performance by Pyro Shows. Argo and City agree to cooperate in good faith regarding rescheduling the event, if necessary, to a mutually agreed upon date. Any costs associated with rescheduling the Event, such as, but not limited to, truck rental, general labor and basic hard cost from Pyro Shows, will be the responsibility of the City and shall not exceed one thousand and five hundred (\$1,500) dollars.

5. This Agreement contains the full and complete understanding of the parties with regard to the subject matter thereof and supersedes all prior representations and understandings, whether written or oral. This Agreement may not be modified in any manner except by written amendment executed by the parties. The Agreement shall be binding upon and inure to the benefit of the parties and their respective heirs, successors and assigns.

6. This Agreement shall be governed by the laws of the State of Mississippi without regard to conflict-of-laws principles. Any action or proceeding seeking to enforce any provision of, or based upon any right arising out of Agreement may be brought against either party in the courts of DeSoto County, Mississippi, or if it can acquire jurisdiction, in the United States District Court for the Northern District of Mississippi. Each party consents to jurisdiction in such courts, and waives any objection to venue laid therein. Process in any action arising under Agreement may be served on any parties anywhere in the world.

7. The invalidity or unenforceability of any provision of this Agreement shall not affect the validity or enforceability of any other provisions of Agreement, which shall remain in full force and effect. If any of the covenants or provisions of this Agreement are determined to be unenforceable by reason of its extent, duration, scope, or otherwise, then the parties contemplate that any court

making such determination shall reduce such extent, duration, scope or other provision and enforce them in their reduced form for all purposes contemplated by this Agreement.

8. Argo shall require all contractors, vendors, and entertainers to execute a waiver of liability/hold harmless agreement in favor of Argo and the City.

9. In carrying out its obligations under this Agreement, Argo shall comply with all rules, regulations, laws and ordinances of the United States, the State of Mississippi, the City of Southaven or Desoto County and all those established by the City for the Event area. Argo shall have the responsibility and shall pay for all permits, licenses, taxes, charges, fees required of it by the laws, ordinances, rules and regulations whether federal, state, county or City, due on account of its business and other permitted activities engaged in under this Agreement. If the attention of the City is called to any violation, Argo will immediately desist and correct the violation.

10. Argo shall not sale and/or provide any alcoholic beverages, including distilled liquors, beer and wine, at the Event. In addition, Argo shall not charge admission to the Event.

11. Argo agrees to assume full responsibility for complying with the Federal Copyright Law of 1978 (17 U.S.C. 101 et seq.) and any regulations issued thereunder including but not limited to the assumption of any and all responsibilities for paying royalties which may be due for the use of the copyrighted work during the Event. Argo shall indemnify the City from any all and all claims, costs, expenses, taxes, losses, or any and all other actions resulting from Argo's failure to comply with this paragraph.

12. Argo shall indemnify the City, its officers, officials, employees, and agents from any and all claims, costs, expenses, suits, losses, or any and all other actions resulting from Argo's duties, representations, and obligations under this Agreement.

13. If required under Mississippi law, Argo shall notify the Mississippi Department of Revenue of the Event contemplated by this Agreement, register the Event, and be liable for any sales tax obligations from the Event. If available, Argo shall provide to the City a tax clearance letter issued by the Mississippi Department of Revenue prior to the Event. Argo shall indemnify the City from any all and all claims, costs, expenses, taxes, losses, or any and all other actions resulting from Argo's failure to comply with this paragraph.

14. The City shall have the right to terminate this Agreement immediately, without notice, and without penalty or liability, in the Event of default by Argo in the performance of any of the terms or conditions of this Agreement

15. This Agreement may be executed in counterparts (each of which shall be deemed to be an original but all of which taken together shall constitute one and the same agreement) and shall become effective when one or more counterparts have been signed by each of the parties and delivered to the other party.

CITY OF SOUTHAVEN

ARGO ENTERTAINMENT, LLC

BY: *Parren Musselwhite* BY: *[Signature]*

Printed Name: Parren Musselwhite Printed Name: DERRILL ARGO JR

Title: Mayor Title: PRESIDENT

INTEROFFICE MEMORANDUM

TO: MAYOR AND BOARD OF ALDERMEN
FROM: EDI MCILWAIN
SUBJECT: MUNICIPAL DEPOSITORY
DATE: 12/22/2022
CC:

In accordance with Mississippi State law, the City of Southaven issued a request for bids for our municipal depository for period January 2023 through December 2026. Two bids were received by the advertised deadline of Tuesday, December 14th. Those financial institutions submitted bids/proposals were Cadence Bank (formerly Bancorp South) and Bank Plus. Attached is a breakdown of their bids and it is my recommendation that the City of Southaven select Cadence Bank as the best bid/proposal to serve as our municipal depository in accordance with state statutes. Cadence Bank offers their services with no banking fees, whereas Bank Plus would charge a monthly fee on all accounts as well as other fees on services. I would further recommend selecting the interest option of the fixed rate at 2.85% due to the uncertainty in the fluctuation of the federal fund target rate.

INSTITUTION	ADDRESS	CITY	ST	FEES	INTEREST	ON-LINE	SERVICES AS REQUESTED	NOTES
First Commercial	5740 Getwell Road	Southaven	MS		NA	NA	NA	No Bid. Offering CD/loans services
First Security Bank	PO Box 690	Batesville	MS		NA	NA	NA	No Bid. Offering CD/loans services
BankPlus	4950 Venture Drive	Southaven	MS		2.00%	Yes	Yes	Fees not waived
First Tennessee	615 Goodman Road E	Southaven	MS		NA	NA	NA	No bid.
BancorpSouth	7125 Airways Blvd	Southaven	MS		2.85% or Fed Funds Target Rate minus 95 basis points with floating rate ceiling 3.5%, floor .05%	Yes	Yes	Fees Waived

**RESOLUTION OF THE MAYOR AND BOARD OF ALDERMEN OF THE
CITY OF SOUTHAVEN, MISSISSIPPI
DECLARING SURPLUS PROPERTY**

WHEREAS, the City of Southaven ("City") Fire Department is presently in possession a 2004 Ford Crown Victoria, Fleet Number 5001, VIN 2FAFP74W84X142770 ("Vehicle")

WHEREAS, pursuant to Mississippi Code 17-25-25, it has been recommended to the Mayor and Board of Aldermen that the Vehicle be declared as surplus and sold and/or disposed of as appropriate and in accordance with Mississippi Code 17-25-25, and removed from the fixed assets inventory; and

WHEREAS, the Vehicle shall be surplused pursuant to Mississippi Code 17-25-25(2); and

WHEREAS, the Mayor and Board of Aldermen are desirous of disposing of the Vehicle and amending, its fixed assets inventory pursuant to State guidelines; and

NOW, THEREFORE, BE IT ORDERED by the Mayor and Board of Aldermen of the City of Southaven, Mississippi as follows, to wit:

1. The Vehicle be hereby declared as surplus property pursuant to Mississippi Code 17-25-25(2) and 17-25-25(5).
2. The City Fire Chief, or his designee, is hereby authorized and directed to any and all actions to effectuate the intent of this Resolution.

Motion was made by Alderman Payne and seconded by Alderman Hoots, for the adoption of the above and foregoing Resolution, and the question being put to a roll call vote, the result was as follows:

REMAINDER OF PAGE LEFT BLANK

Alderman William Jerome	voted: YES
Alderman Kristian Kelly	voted: YES
Alderman George Payne	voted: YES
Alderman Joel Gallagher	voted: YES
Alderman John David Wheeler	voted: YES
Alderman Charlie Hoots	voted: YES
Alderman Raymond Flores	voted: YES

RESOLVED AND DONE, this 20st day of December, 2022.



Darren Musselwhite, MAYOR

ATTEST:



CITY CLERK



RESOLUTION GRANTING AUTHORITY TO CLEAN PRIVATE PROPERTY

WHEREAS, the governing authorities of the City of Southaven, Mississippi, have received numerous complaints regarding the parcel of land located at the following address, to-wit:

CONDEMNATION ADDRESS

7885 Highway 51

7593 Millbridge Dr

253 GOODMAN RD. W

to the effect that the said parcel of land has been neglected whereby the grass height is in violation and there exist other unsafe conditions and that the parcel of land in the present condition is deemed to be a menace to the public health and safety of the community.

WHEREAS, pursuant to Section 21-19-11 of the Mississippi Code Annotated (1972), the governing authorities of the City of Southaven, Mississippi, provided the owners of the above described parcel of land with notice of the condition of their respective parcel of land and further provided them with notice of a hearing before the Mayor and Board of Aldermen on Tuesday, December 20, 2022, by United States mail and by posting said notice, to determine whether or not the said parcel of land were in such a state of uncleanness as to be a menace to the public health and safety of the community.

WHEREAS, none of the owners of the above described parcel of land appeared at the meeting of the Mayor and Board of Aldermen on Tuesday, December 20, 2022, to voice objection or to offer a defense.

NOW, THEREFORE, BE IT HEREBY RESOLVED, by the Mayor and Board of Alderman of the City of Southaven, Mississippi, that the above described parcel of land located at:

CONDEMNATION ADDRESS

7885 Highway 51

7593 Millbridge Dr

253 GOODMAN RD. W

is deemed in the existing condition to be a menace to the public health and safety of the community.

BE IT FURTHER RESOLVED that the City of Southaven shall, if the owners of the above described parcel of land do not do so themselves, immediately proceed to clean the respective parcel of land, by the use of municipal employees or by contract, by cutting weeds and grass and removing rubbish and other debris.

Following the reading of this Resolution, it was introduced by Alderman Payne and seconded by Alderman Hoots. The Resolution was then put to a roll call vote and the results were as follows, to-wit:

ALDERMAN	VOTED
Alderman William Jerome	voted: YES
Alderman Kristian Kelly	voted: YES
Alderman George Payne	voted: YES
Alderman Joel Gallagher	voted: YES
Alderman John David Wheeler	voted: YES
Alderman Charlie Hoots	voted: YES
Alderman Raymond Flores	voted: YES

The Resolution, having received a majority vote of all Aldermen present, was declared adopted on this, the 20th day of **December, 2022**.

CITY OF SOUTHAVEN, MISSISSIPPI BY:

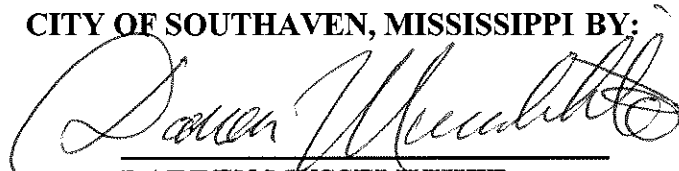

DARREN MUSSELWHITE
MAYOR

ATTEST:



ANDREA MULLEN
CITY CLERK
(S E A L)



Network: Dec 6, 2022 at 9:37:22 AM CST

Local: Dec 6, 2022 at 9:37:22 AM CST

N 34.962314° W 89.994706°

253 Goodman Rd W
Southaven MS 38671
United States

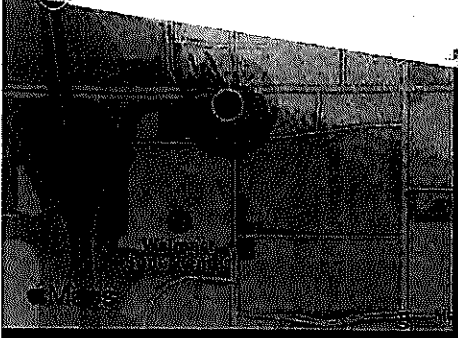

NEW YORK TIMES by 2642 ET 9:49:02 AM US I

Local: Dec 6, 2022 at 9:45:32 AM CST

N 34 DE 50 W 89 90 2 00

258 Goodman Run

Southaven MS 38671

United States

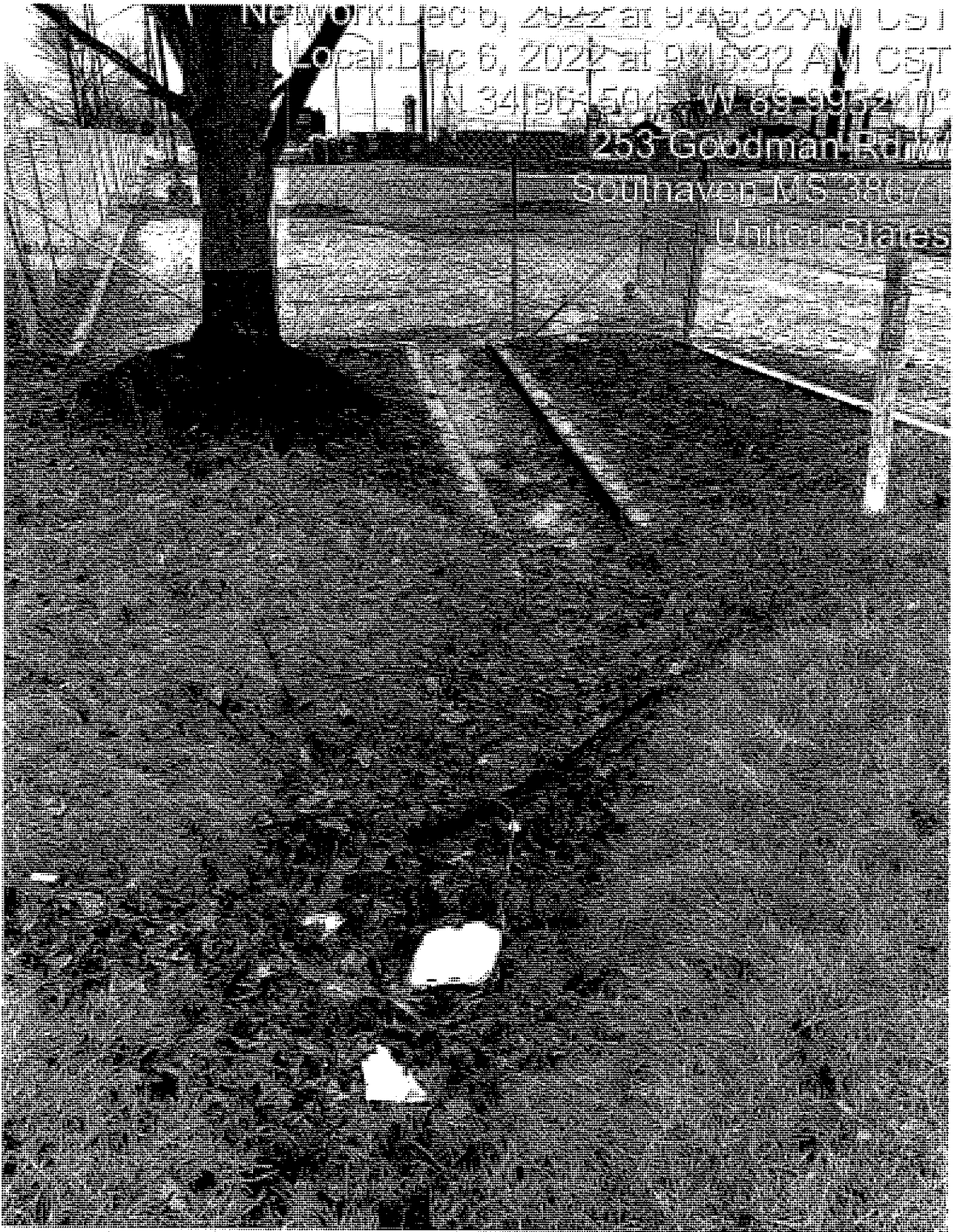

Network: Dec 6 2023 at 9:15:19 AM CST

Local: Dec 6 2023 at 9:15:19 AM CST

N 34.964529 W 89.995347

287 Goodman Rd V

Southaven MS 3867

United State



Network: Dec 5, 2022 at 12:37:55 PM CST

Local: Dec 5, 2022 at 12:37:55 PM CST

N 34.975282°, W 90.016323°

7887 US-51 N

Southaven MS 38671

United States

Network: Dec 5, 2022 at 12:59:56 PM CST

Local: Dec 5, 2022 at 12:59:56 PM CST

N 34.975224°, W 90.016382°

7885 US-51 N

Southaven MS 38671

United States

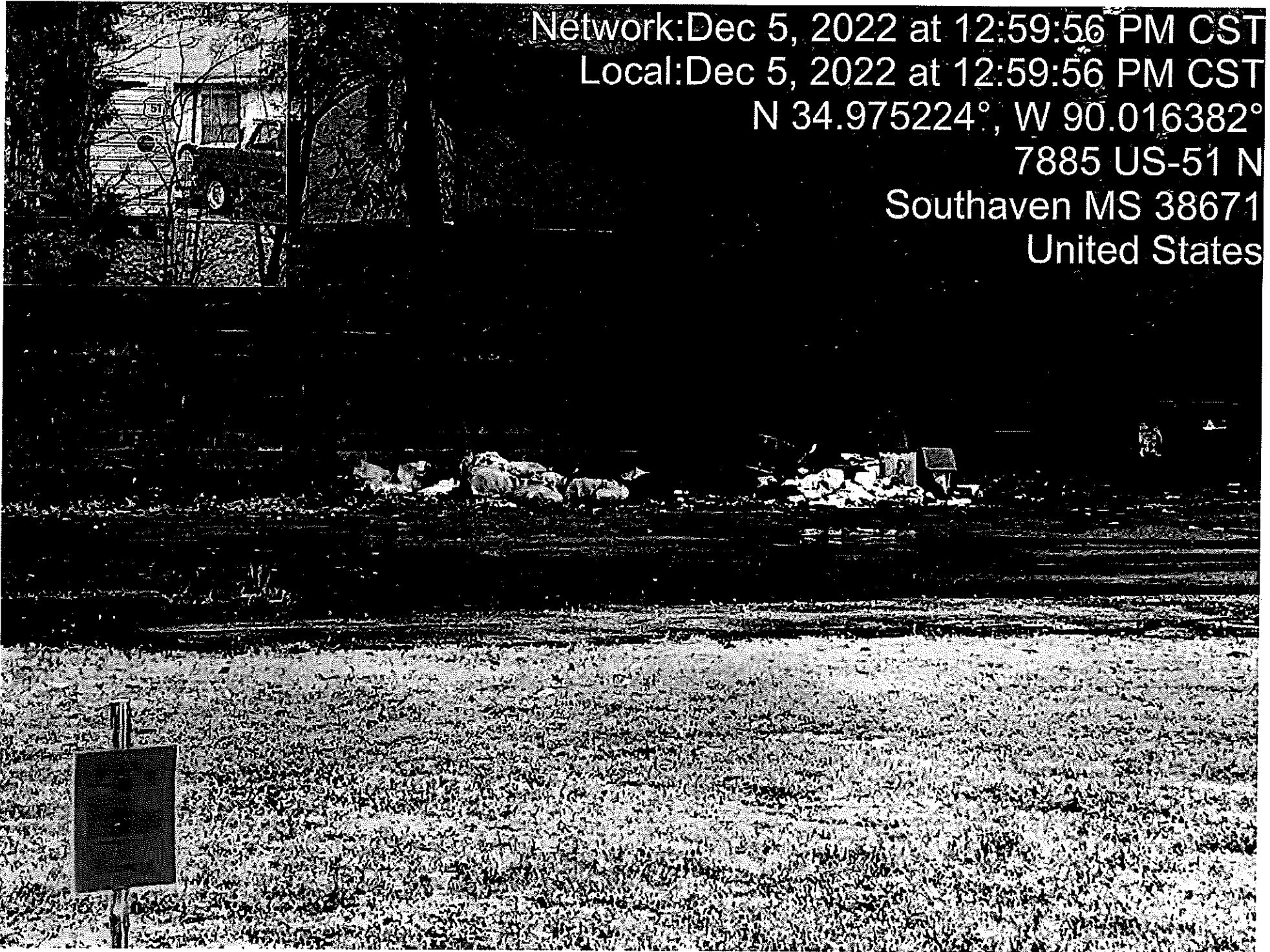

Network: Dec 5, 2022 at 1:25:10 PM CST

Local: Dec 5, 2022 at 1:25:10 PM CST

N 34.971455°, W 89.982650°

7592 Millbridge Dr
Southaven MS 38671
United States

Millbridge
East Millbridge

Millbridge

Millbridge

Millbridge

Millbridge

Millbridge

Millbridge

Millbridge

Millbridge

Millbridge

Millbridge

Millbridge

Millbridge

Millbridge

Millbridge

Millbridge

Millbridge

Millbridge

Millbridge

Millbridge

Millbridge

Millbridge

Millbridge

Millbridge

Millbridge

Millbridge

Millbridge

Millbridge

Millbridge

Millbridge

Millbridge

Millbridge

Millbridge

Millbridge

Millbridge

Network: Dec 5, 2012 at 1:27:37 PM CST

Local: Dec 5, 2012 at 1:27:37 PM CST

N 34.971586 W 89.982536

7592 Millbridge Dr

Southaven MS 38671

United States

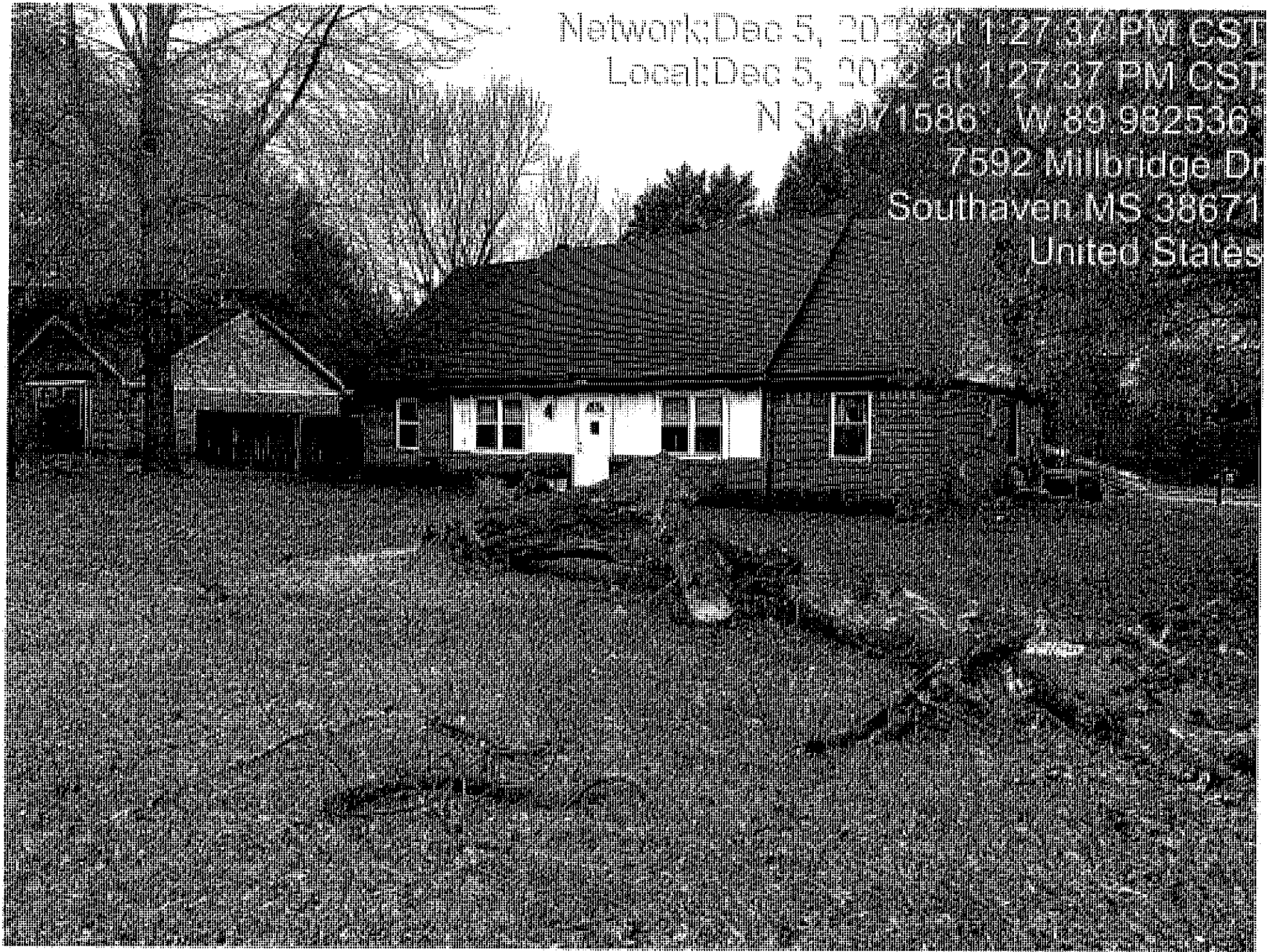

**Office of Planning and Development
Planned Unit Development Staff Report**

Planning Commission:
November 28, 2022
Applicant:
West Realty Partnership, LP 6165 Chartwell Lane Memphis, TN 38120 901-262-9980
Representative:
The Reaves Firm c/o Mike Davis 680 Poplar Avenue Suite 101 Memphis, TN 38138 901-761-2016
Location:
South of Church Road, on the east and west side of Airways Blvd.
Total Acreage:
113.3 Acres
Existing Zoning:
PUD and agriculture
Staff Findings:
<p>ORIGINAL SUBMITTAL:</p> <p>The applicant is requesting to rezone 113.3 acres south of Church Road on the east and west sides of Airways Blvd.</p> <p>The applicant is a family who owns the property, and the request is provide a general master design to assist the family in marketing the plan for sale to a developer who can then submit a more defined design detail as the development moves forward. The goal of this master plan is to create a road network and detention plan that will allow the overall development to work. The details included in this plan identifies those components while also providing a general use description for blocks of areas. Exclusions to the permitted uses for each area have been identified in the text and should be referenced in discussion. Also included in this submittal is the identification of major mature tree growth and a conceptual design that will embrace those areas and preserve them.</p> <p>The following criteria has been submitted:</p> <p>Areas A/B/C: These areas have major road frontage on both Church Road and Airways Blvd. Per the text, they shall permit uses under Planned Commercial (C-4) zoning per the city of Southaven zoning ordinance. Additional flexibility includes the allowance of mixed</p>

use buildings and/or office space on the rear portions of Areas B and C, all of which will be required to submit for site plan and design review. The proposed possibility of mixed use lofts on a second or third story shows a minimum heated square footage of 1,100 sq. ft.

Area D: is located on the west side of Airways Blvd., completely detached from the remainder of the development. The existing development along this corridor is larger box warehousing and planned business park. The applicant has created a transition zone in this area to provide a mixture of smaller footprint warehousing with office and commercial space along the road frontage to create a buffer zone. Per the text, the maximum footprint for any warehousing would be 150,000 sq. ft. Old Airways Blvd. is shown at the north end of this section which is an approved relocated roadway funded by MDOT with the overall Church/I55 project.

Area E: is a long narrow strip of the property that has full visibility from Airways Blvd., which is limited in depth due to the Horn Lake Creek Lateral D being situated along the eastern boundary of this area. The application proposes small scale footprint office use and possibly a live/work concept for this area.

Area F: is on the interior of the site with minimal visibility to Airways Blvd. The conceptual plan for this area provides three options including an office campus setting, active senior living or medium density residential. Although there is access shown from Airways and Church via a collector road on the interior of the site, the main entrance for this portion of the property would be from Elmore Road extension, which is shown as part of the master road design for this project.

Area G: is proposed for single family residential with overall bulk regulations matching the R-15 district. Although this area transitions into the low density residential of the surrounding areas, the plan is to design this for cluster development to allow preservation of a mature trees identified. The minimum heated square footage is proposed at 2,500 sq. ft.

Detention for the overall plan has been conceptually shown which situates ponds along the existing creekline. There are three major points of entrance into the development, two of which will require a bridge crossing over the waterways and the other which will require a section line road extension. Interior roads will be determined as the project advances into a more detail design stage. The text provides a typical section for the collector roads which all show a sixty eight (68) foot right of way with two twelve (12) foot lanes, a fifteen (15) foot center median and sidewalks on both sides of the road.

Staff Final Recommendations:

Prior to this application, there was a PUD approved which included heavy commercial and planned business park on this entire piece of property. That PUD has since been vacated due to lack of activity on the site. Staff believes the new proposed mixture of uses for the property is more beneficial to the city, less impactful to the traffic and more embracing of the natural landscape.

The applicant has provided a good infrastructure design for detention and traffic circulation for the overall development. Staff is acceptable to the general concept of bubble design for each section since this development is not at a stage of design and construction. Staff is also acceptable to the flexibility proposed for sections. This is a large tract of land and it is impossible to determine the future development needs for the area so the flexibility allows both the owners and the city to make a determination at the necessary point in time as to what should go in the specific areas. This project, as noted in the text, is entirely in the Metro District of the city which has its own set of guidelines and restrictions. Those restrictions ensure that commercial and office developments in this area are of the highest quality and provide a central business area feel.

Staff greatly appreciates the preservation of the mature trees. There are identified areas at the south end of this property which have trees in excess of 60 years old. It is more important to staff to preserve a tree area than it is to designate areas for high/medium/low density residential. Staff would recommend taking this approach to the entire residential area and, if possible, to Area D where there are identified mature trees as well.

Staff has a couple of concerns/questions:

1. The heated minimums are addressed for Area C and G but not Area F. Can the applicant provide those heated minimums as well?
2. Elmore Road is a section line road which will require right of way from other parties. The applicant has discussed the options for this road but staff would like to clear up the concept and responsibility for the road extension.

Staff recommends approval as submitted.



November 7, 2022

1:9,028

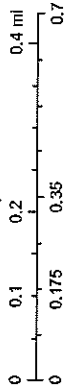

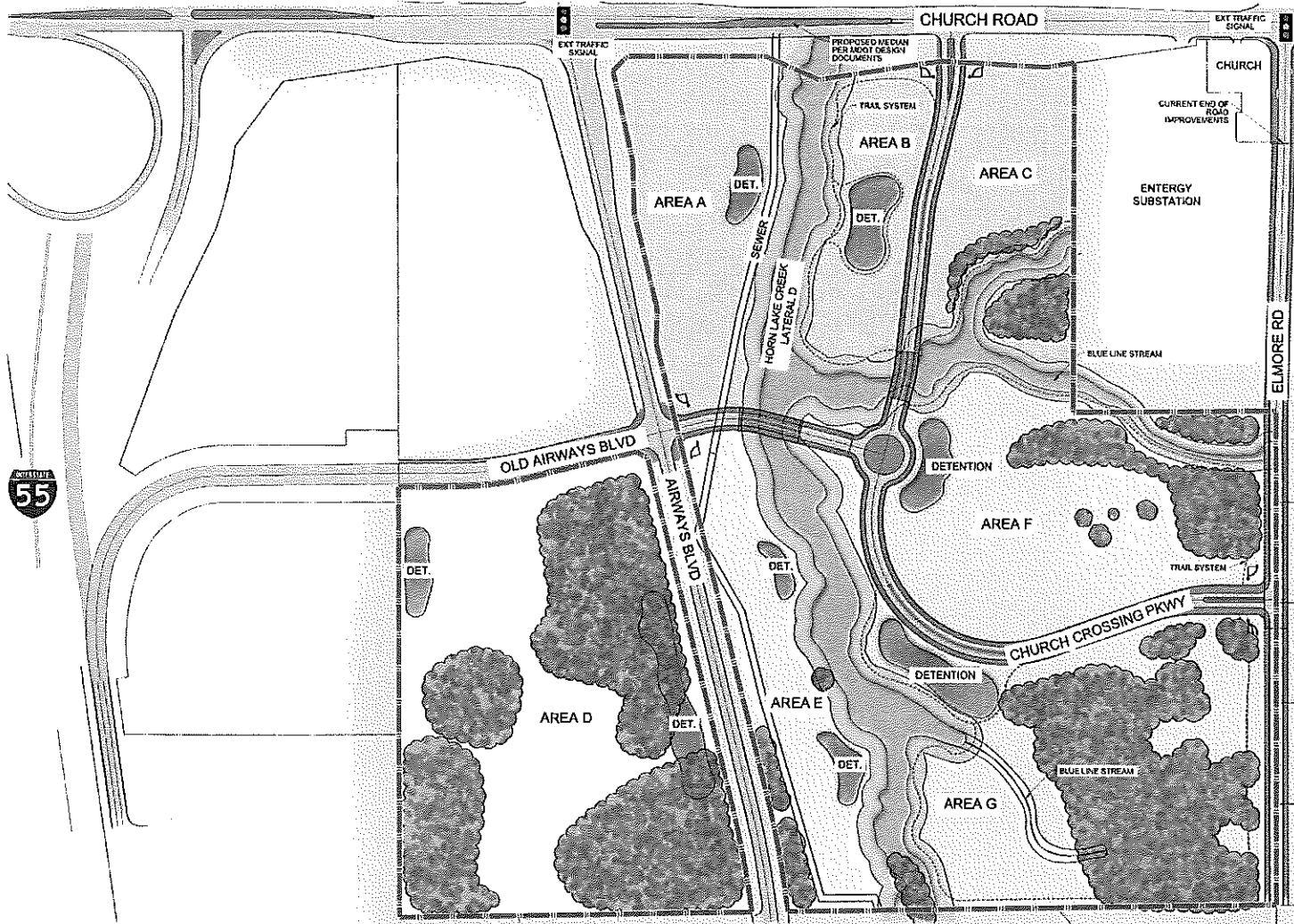

Areas

Areas A, B and C are prime retail locations due to their street visibility and proximity to the Interstate 55/Church Road interchange and Tanger Outlets. Area A is a logical hotel site that would act as an architectural centerpiece for the property. The rear portions of Areas B and C could transition to office or residential loft uses.

Area D is a transitional step-down area from the existing big box warehouses to the south. It is ideally situated for a regional big box destination retailer that is not dependent on street visibility. This area could also be used as a contractor business park with limited retail along the future realignment of Old Airways.

Area E is limited by buildable depth, but is ideal for small business and work/live units along the New Airways Frontage.

Areas F and G lack visibility but would be ideal for office campus; active adult; or medium density, single-family residential uses.

Area G is a transition zone, as it abuts existing rural residential uses. Cluster development will be required in Area G to preserve large areas of existing old-growth forest.

The Horn Lake Creek Greenway and associated site tributaries should remain intact and used as passive common area recreation. It should be equipped with a trail system and benches and be available for use by all site tenants. All common area within the development will be maintained by a property owner association.

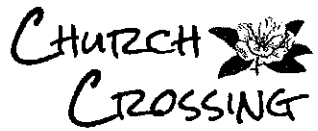

CONCEPTUAL LAND USE PLAN

The Reaves Firm

INCORPORATED

Planning
Engineering
Landscape Architecture
Land Surveying

6800 Peyton Ave, Ste 101 | Memphis, TN 38118
901.741.2016 | www.reavesfirm.com

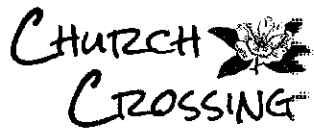
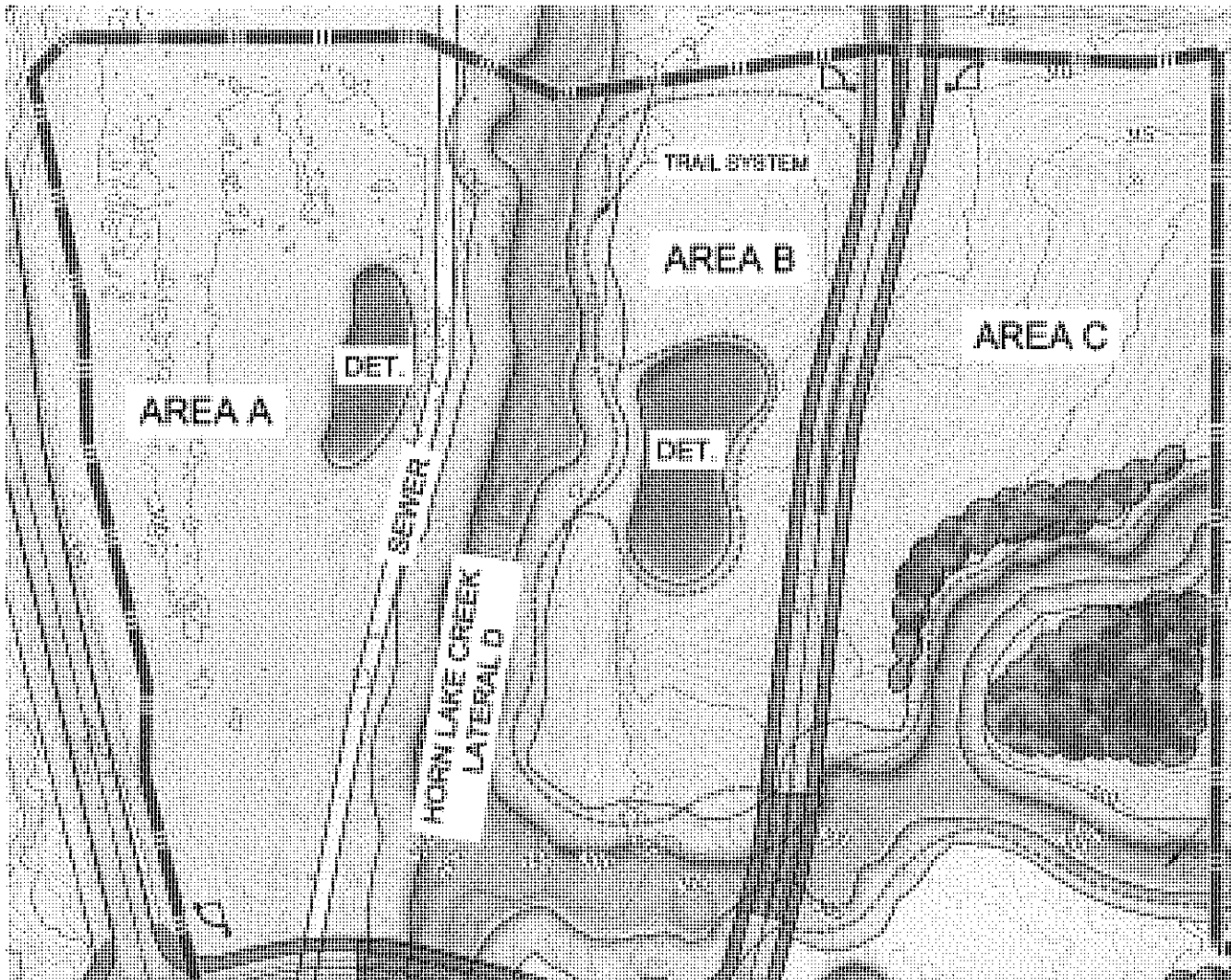

AREA ENLARGEMENT WITH EXISTING TOPOGRAPHY 11

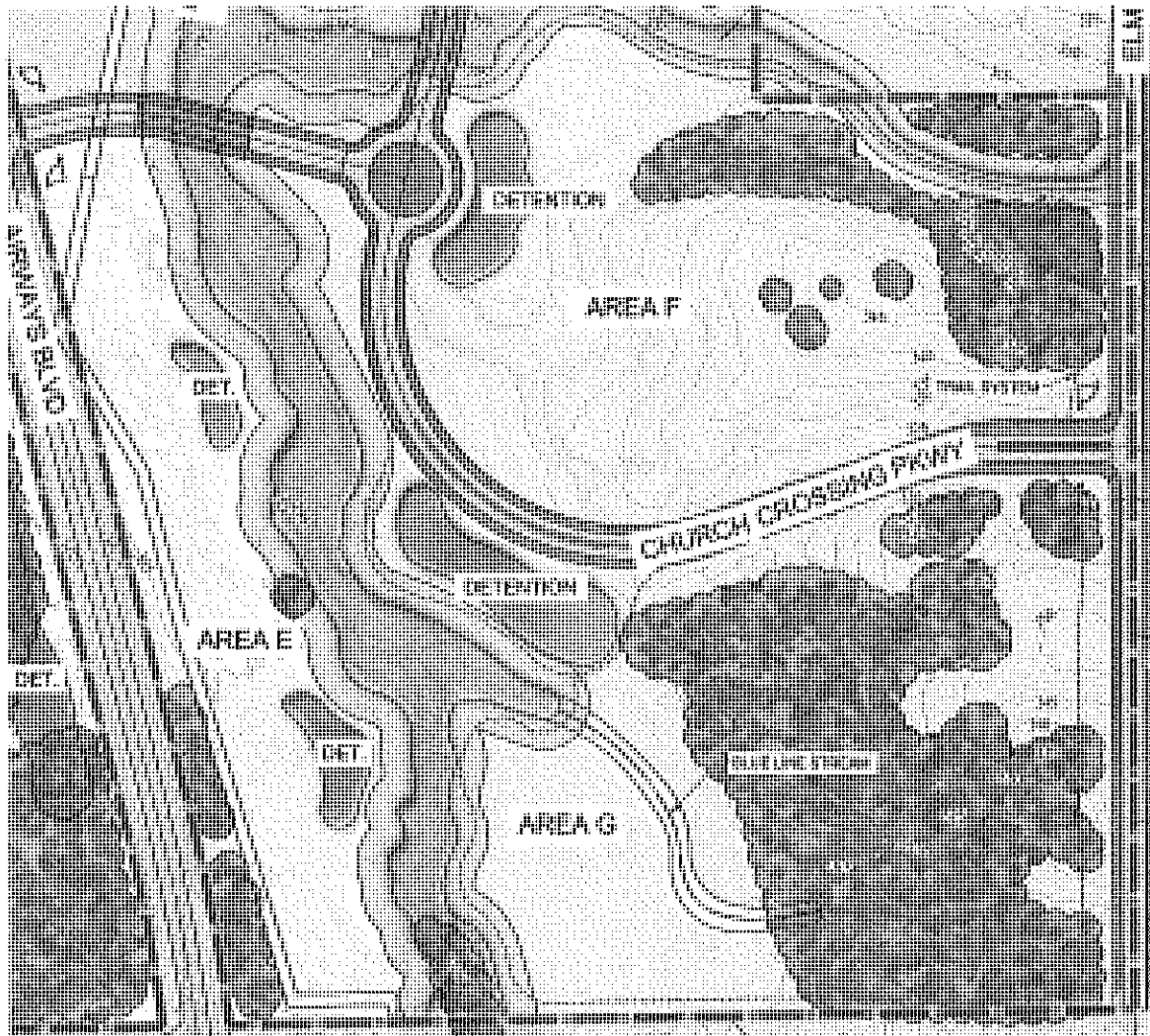

CHURCH
CROSSING

AREA ENLARGEMENT WITH EXISTING TOPOGRAPHY 12



The Reaves Firm
INCORPORATED
Planning
Engineering
Landscape Architecture
Land Surveying
6600 Ryals Ave, Ste 101 | Memphis, TN 38133
901.743.2016 | www.reavesfirm.com

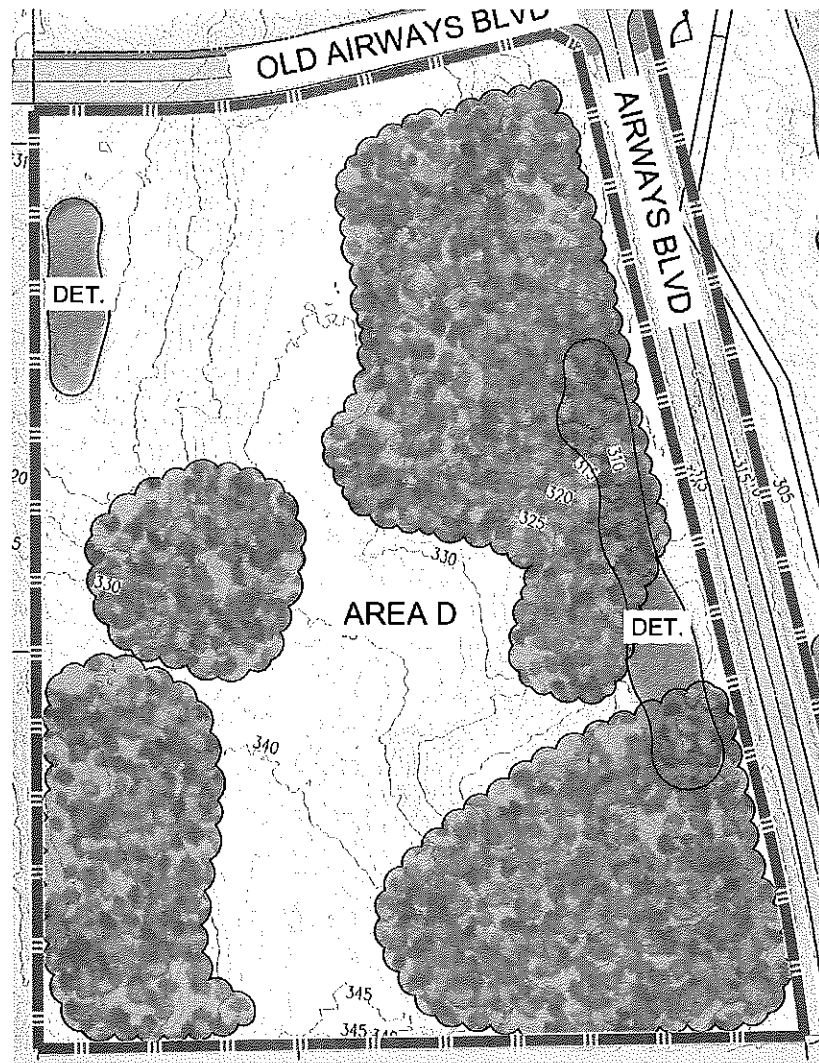

CHUTZCH
CROSSING

AREA ENLARGEMENT WITH EXISTING TOPOGRAPHY 13



The
Reaves
Firm
INCORPORATED
Planning
Engineering
Landscape Architecture
Land Surveying
6200 Peachtree Dunwoody, Ste. 101 | Marietta, GA 30067
901.761.2016 | www.the-reaves.com

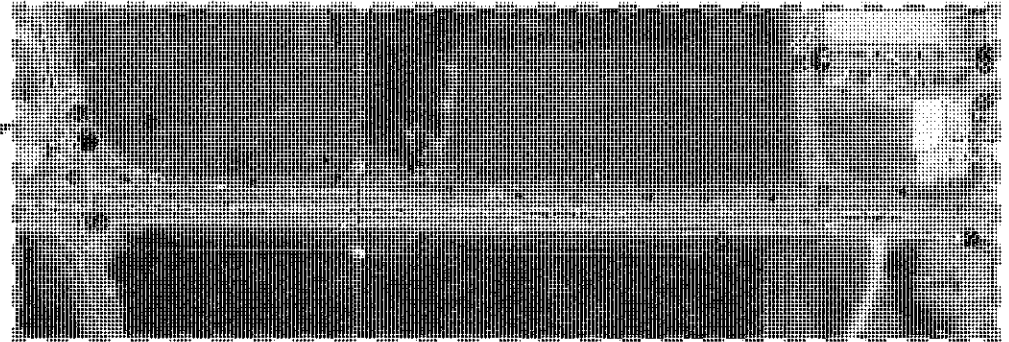

- Electric: Provided by Entergy Mississippi
- Sewer: Provided by Horn Lake Creek Interceptor Sewer Dist.
- Sewer: Provided by City of Southaven, 10 & 12"
- Water: Provided by City of Southaven, 12" line on south side of Church Rd

CHURCH
CROSSING

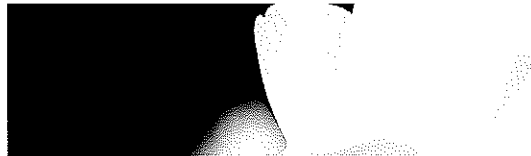

EXISTING UTILITIES

14



The
Reaves
Firm
INCORPORATED
Planning
Engineering
Landscape Architecture
Land Surveying
6800 Poplar Ave, Ste 101 | Memphis, TN 38138
901.761.2016 | www.reavesfirm.com

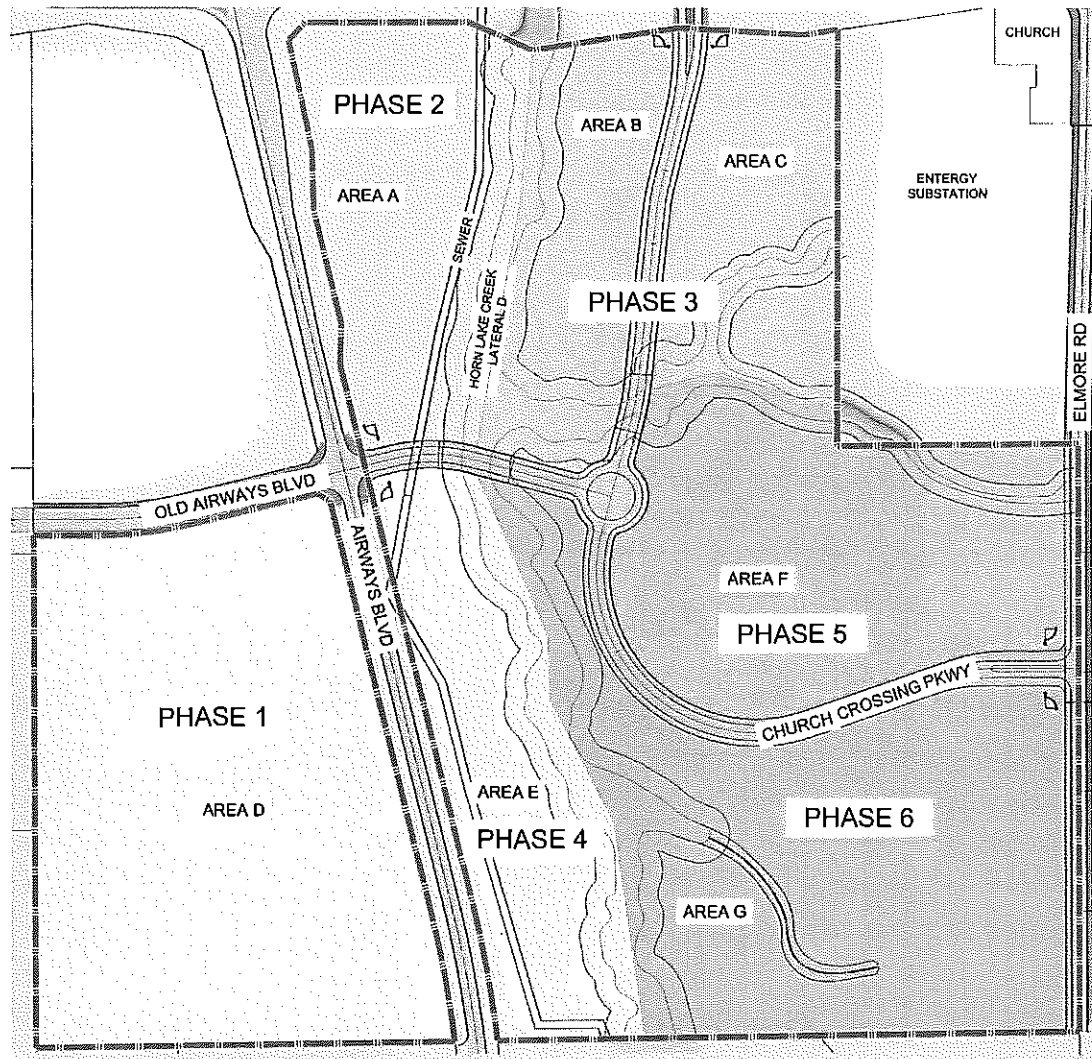

Project Phasing

- Phase 1: Area D
- Phase 2: Area A
- Phase 3: Areas B and C (including roundabout and northern section of Church Crossing Parkway)
- Phase 4: Area E
- Phase 5: Area F
- Phase 6: Area G (including the southern and western portions of Church Crossing Parkway)

CHURCH CROSSING

PROJECT PHASING
15

The Reaves Firm
INCORPORATED
Planning
Engineering
Landscape Architecture
Land Surveying
6800 Pryor Ave, Ste 101 | Memphis, TN 38138
901.761.2016 | www.reavesfirm.com

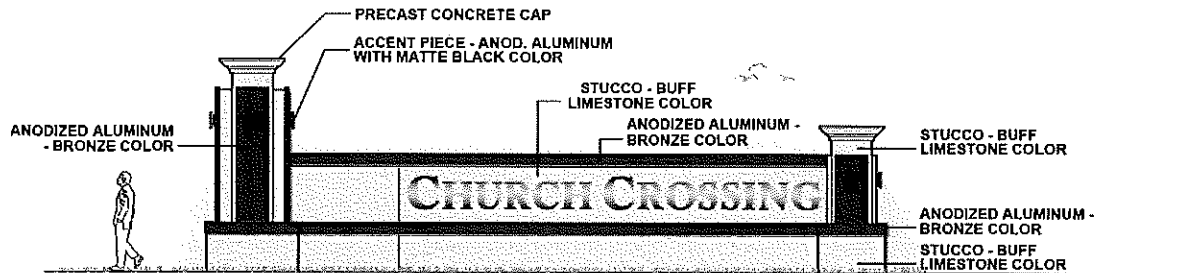

Elevation

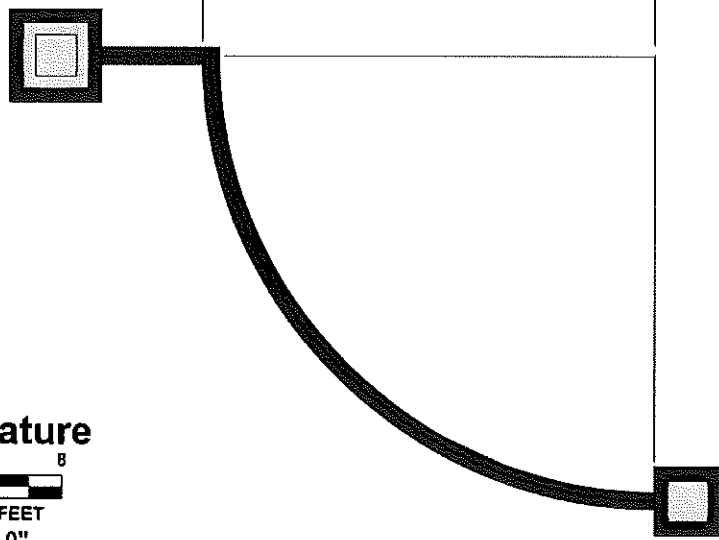

Plan View

Entrance Feature



GRAPHIC SCALE IN FEET
SCALE: 1/8"=1'-0"

CHURCH CROSSING



ENTRY TREATMENT

16

The Reaves Firm INCORPORATED
 Planning
 Engineering
 Landscape Architecture
 Land Surveying

6500 Regal Ave., Ste 101 | Memphis, TN 38118
 901.761.2016 | www.thereavesfirm.com

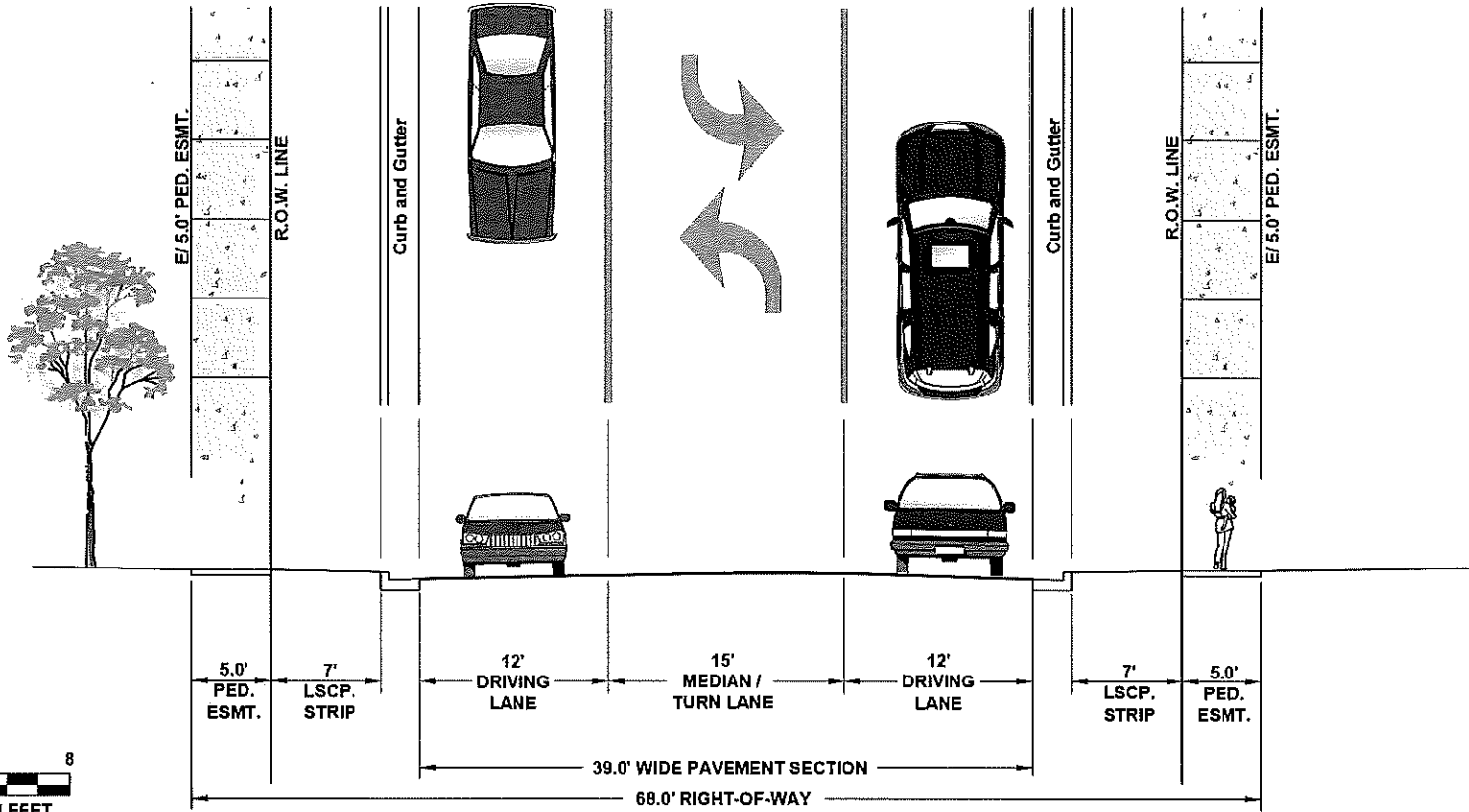

**Typical Cross Section
All Streets**

**CHUTZCH
CROSSING**

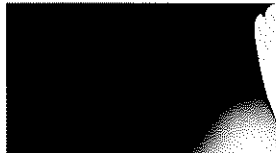

**The
Reaves
Firm**
INCORPORATED
Planning
Engineering
Landscape Architecture
Land Surveying
6800 Lytle Ave, Ste 101 | Memphis, TN 38138
901.254.2016 | www.thereavesfirm.com

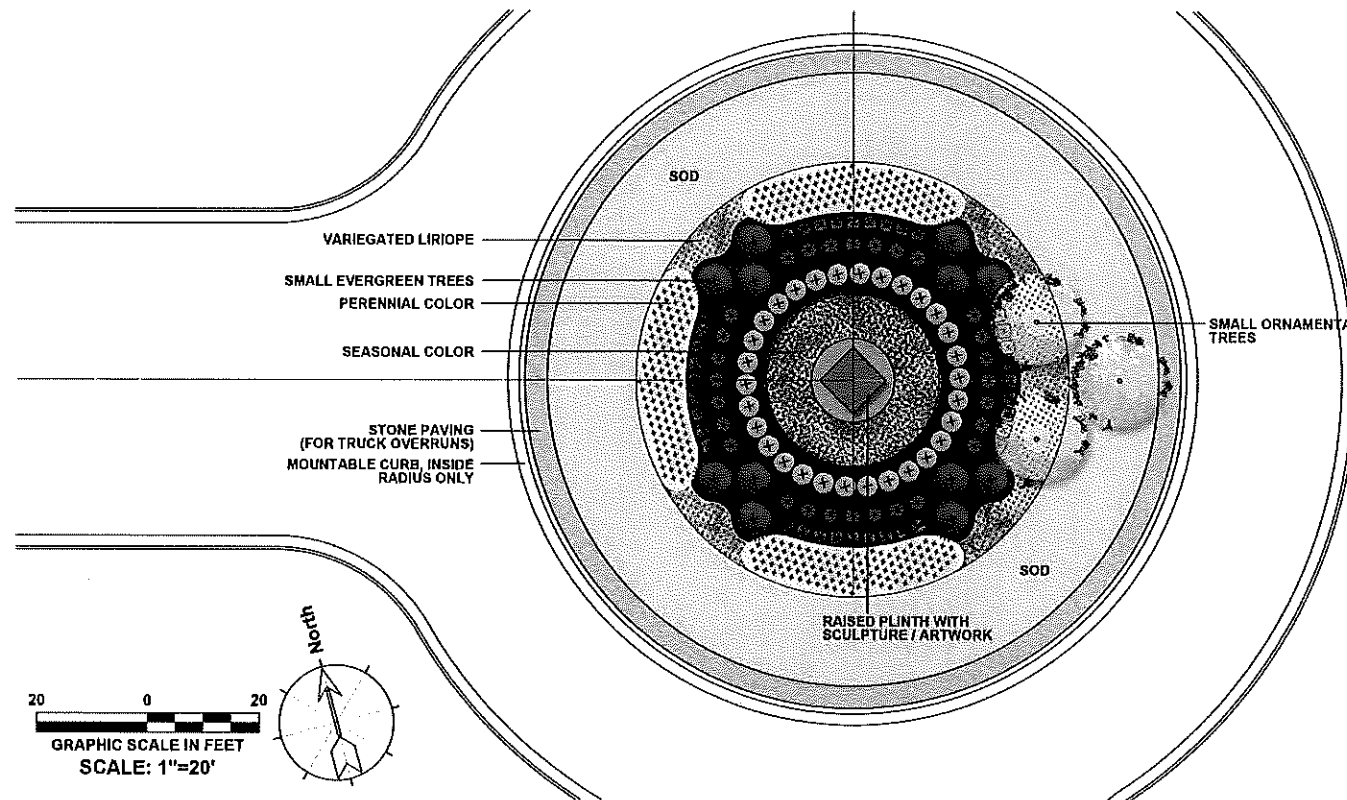

- VARIEGATED LIRIOPE
- SMALL EVERGREEN TREES
- PERENNIAL COLOR
- SEASONAL COLOR
- STONE PAVING
(FOR TRUCK OVERRUNS)
MOUNTABLE CURB, INSIDE
RADIUS ONLY

SMALL ORNAMENTAL
TREES

RAISED PLINTH WITH
SCULPTURE / ARTWORK

ROUNDAABOUT
PLAN VIEW

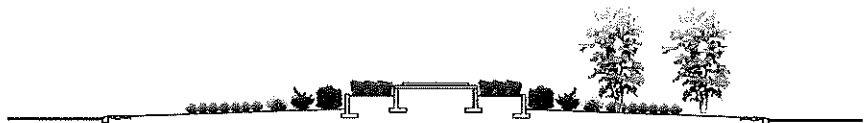

SECTION

CHURCH
CROSSING



The Reaves Firm
INCORPORATED
Planning
Engineering
Landscape Architecture
Land Surveying
6601 Rylee Ave, Ste 101 | Memphis, TN 38134
761.751.2616 | www.reavesfirm.com

I. Uses Permitted:

A. Area A, B, C, and E: The uses permitted shall be in accordance with the Planned Commercial (C-4) District with the additional allowed uses of Loft Apartments and Live-Work Units. The following uses shall not be permitted:

1. Automobile dealerships (new or used) or automobile rental offices
2. Big box: Categories A, B, & C
3. Carwash
4. Carwash as an accessory to a convenience store
5. Carnival
6. Cemetery, mausoleum, columbarium, memorial park
7. Contractor's storage (indoor)
8. Convenience food store
9. Donation boxes
10. Dry cleaning establishment, full-service laundry
11. Dry cleaning/laundry establishment, pick up/delivery only
12. Gas pumps as an accessory to convenience store
13. Kennel
14. Liquor store
15. Lounges, bars, taverns and similar establishments
16. Outdoor stales and storage
17. Radio/TV tower, antenna, earth station greater than 35' in height

B. Area D: The uses permitted shall be in accordance with the use regulations of the Planned Business Park (PBP) with the additional allowed uses of Big box – Category A, Contractor's storage (indoor), Contractor's yard or storage, outdoor (screened), and Grocery. The following uses shall not be permitted:

1. Radio/TV tower, antenna, earth station greater than 35' in height

C. Area F and G: The uses permitted shall be in accordance with the use regulations of Residential-15 (R-15) and the Office District (OD). Additionally, a senior living facility or retirement community shall be allowed. The following uses shall not be permitted:

1. Big box category A
2. Radio/TV tower, antenna, earth station greater than 35' in height
3. Dry cleaning establishment, full-service laundry
4. Dry cleaning/laundry establishment, pick up / delivery only
5. Cemetery, mausoleum, columbarium, memorial park
6. Kennel
7. Garden apartments

8. Residential condominium

9. Duplex/two-family

II. Site Development Regulations:

A. Bulk regulations:

1. Area A, B, C, and E: Shall follow the bulk zoning regulations of the C-4 District.
2. Area D: Shall follow the bulk zoning regulations of PBP except the maximum building size allowed shall be 150,000 SF.
3. Areas F and G: Follow the bulk zoning regulations of R-15 and OD.
- B. In Area C: Lofts shall be a minimum 1,100 SF and are located on the second floor or higher of mixed-use buildings.
- C. Buildings in Area G will be developed in a cluster style, to preserve areas of old-growth forest. Single-family residential shall have a minimum heated square footage at 2,500 SF.
- D. Setbacks, building heights, and density within each development area may be modified administratively by the Southaven Planning Department in accordance with the Southaven Metropolitan District regulations.

III. Roadways, Access, Parking, and Circulation:

- A. All proposed public roads shall be dedicated in accordance with the City of Southaven Design Standards.
- B. All proposed public roads shall be a 68' ROW consisting of three-lanes with a median turn lane.
- C. Area F and G cannot be developed until either Elmore Road or Old Airways Blvd are extended to the site.
- D. Pedestrian circulation within the planned development shall include sidewalks on both sides of Church Crossing Parkway and a comprehensive trail system throughout the creek buffer zone

IV. Landscaping, Lighting, Screening, and Open Space:

- A. As the entire property is tree covered, the Southaven Tree ordinance shall apply.
- B. All Common Open Space including the 50' buffer along Lateral D of Horn Lake Creek shall be maintained by a property or homeowner's association and covenants, conditions, and restrictions (CCR's) shall be recorded prior to the recording of the first final plat in said area.
- C. All healthy trees shall be preserved within the 50' buffer of the Horn Lake Creek measured from top of bank.
- D. A tree survey shall be required at the time of development of each area.
- E. Landscaping of parking lots shall comply with City of Southaven's regulations.
- F. Landscape Plate A-3 or equivalent shall be along Church Crossing Blvd, Airways Blvd, Old Airways Blvd, Church Rd, and Elmore Rd.
- G. All dumpsters shall be enclosed in masonry with a metal gate, screened from view of public right of ways, and screened with evergreen landscaping.
- H. Loading docks and utility meters, junction boxes, transformers, and other utilities appurtenances shall be screened from public view.

CHURCH
CROSSING

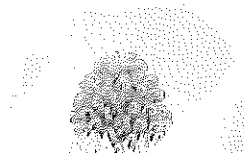

CONDITIONS
19

The Reaves Firm
INCORPORATED

Planning
Engineering
Landscape Architecture
Land Surveying

6500 Poplar Ave, Ste 101 | Memphis, TN 38138
901.261.2916 | www.reavesfirm.com

I. Parking lot lighting shall not exceed 4,000 kelvin or equivalent.

V. Signage:

- A. Signage for each area shall comply with City of Southaven's regulations. Signage types not permitted include: video or digital signs and signs that make noise or exude smoke-like substance. Signs cannot be in the shape of a motif such as a boot or a hamburger. Nationally recognized corporate logo signs, however, are permitted.
- B. Ground mounted signs shall have a masonry base.
- C. Internally illuminated signage shall be white. Externally illuminated signage can be the developer's choice.
- D. External illumination shall not exceed 4,000 kelvin or equivalent.

VI. Drainage Facilities and Services:

- A. Lateral D of Horn Lake Creek is considered waters of the state and a 50' buffer is required from TOB.
- B. Other streams shown as blue lines on the quad maps shall be evaluated at the time of development. In the planned development they are shown with a 30' buffer from top of bank.
- C. The developer is required to have an environmental assessment done on each section for wetlands and waterways.
- D. Stormwater detention shall be provided on a regional basis and maintained privately, either by individual property owners or by a property owner association.
- E. Actual footprints of the detention areas shall be determined during final development layouts and designed as visual amenities.

VII. Sanitary Sewer:

- A. The sanitary sewer system shall be designed and constructed by the developer according to state and city regulations and specifications.
- B. Sewer plans must be submitted for review to the City Engineer during the final phase of the site plan.

VIII. Water Service / Utilities:

- A. Public water system shall be designed and constructed by the developer according to the state and city regulations and specifications.
- B. Water service lines shall be installed with tracing wire at the top.
- C. All utilities shall be below ground except for three-phase electric power.

IX. Architectural Requirements:

- A. Architectural design shall be in accordance with the Southaven Metropolitan District regulations and the Southaven Design Review Manual.

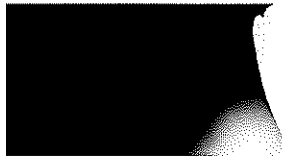
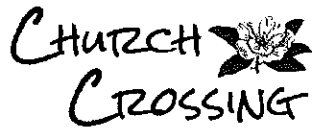

Office of Planning and Development Planned Unit Development Staff Report

Planning Commission:
November 28, 2022
Applicant:
SMJ Enterprise, LLC 8275 Tournament Drive Suite 100 Memphis, TN 38125 901-440-1370
Representative:
Same
Location:
East of Tchulahoma Road, north of proposed Nail Road
Total Acreage:
144 Acres
Existing Zoning:
Snowden Farms Planned Unit Development
Staff Findings:
<p>ORIGINAL SUBMITTAL:</p> <p>The applicant is requesting to rezone 144 acres on the east side of Tchulahoma Road north of proposed Nail Road from the Snowden Farms PUD to Serenity Pointe PUD. This area includes mixture of low density, medium density, high density attached and assisted living.</p> <p>The following criteria has been submitted:</p> <p>Area A: Area A includes two sections of housing which incorporates assisted living and attached high density. The assisted living portion encompasses 7.14 acres and is shown on the eastern most portion of the site with two points of access off of Nail Road. The attached units are shown as homeowner occupied townhomes or condominiums which are shown as fourplexes. The site plan submitted with the master plan proposes two options in this area “senior cottages” with a 1,200 heated square footage and non-age restricted housing with a 1,800 heated square footage. The density breakdown for the assisted living is not submitted with the plan which can be addressed at a later date with the site plan. The density shown for the attached dwelling area placed a maximum of 12 units per acre. The applicant submitted a PDF brochure of the proposed design for this area which has been included in the PC packages.</p> <p>Area B: This area is shown with 28.27 acres and single family residential lots which back up to Area A. There are two points of access from Nail Road included and 98 lots with a standard dimension of 50’x125’. The minimum heated square footage is proposed</p>

at 2,200 sq. ft. Per discussion with the applicant, this area has been designed similar to the cottages in Silo Square which maintains the same lot sizes but actually has a 1,800 minimum heated square footage. Access to open space to the west of these homes is shown via a green trail at two separate points in the lots.

Area C: This area encompasses 48.39 acres and includes 139 lots with a standard dimension of 80'x125'. This portion of the development is proposed as gated with access from Tchulahoma Road only. The minimum heated square footage for these lots have been proposed at 2,800 sq. ft. This area has common open space on both the east and west side which the applicant has shown accessibility via several green trail points.

Area D: This area has a total of 11.60 acres of land with 19 lots showing a minimum of 20,000 sq. ft. The heated minimum for this area has been proposed at 3,000 sq. ft. and it shown as a gated access area directly from Tchulahoma Road. Both D and C have access into each area via the street systems and ingress/egress from Tchulahoma Road entrances. There are two green space access areas shown for this section as well.

AREA E: This section is only 5 lots of 2 acres each with direct access off of Nail Road. In speaking with the applicant's representative, this area has some environmental constraints with a creek line and has some very mature trees that the applicant felt removing would be detrimental to the overall site. The house minimums for this area have not been identified by the applicant.

Common open spaces are shown throughout the development. COS A and B are larger areas with A having 17.06 acres and B with 7.63 acres. Both of these spaces propose a connected walking trails. The hard corner at Tchulahoma Road and Nail Road shows a large wet pond surrounded by a walking trail. These COS, per the PUD text make up 18.3% of the overall site.

Internal road design shows a standard fifty (50) foot right of way with two lanes of traffic showing thirteen (13) feet in width and five (5) foot sidewalks on both sides. In the areas where there is gated access and guard house, the applicant has shown a fifty five (55) foot wide right of way to allow for the needed common open space. The typical section for Nail Road shows a fifty three (53) foot right of way dedication with a single drive lane, an eight (8) foot shoulder, sidewalk and utility easements.

Staff Final Recommendations:

Questions and concerns by staff:

Area A:

- The applicant references cottage homes and townhomes but there is not determination on which is proposed and where? Staff would like further definition on the options in this area.
- The density estimate for the assisted living and number of stories should be identified. Staff understands that the master plan identifies the potential use but the rooms in this area will assist staff in calculating overall density and other bulk

regulations. Can the applicant provide an estimated room count?

- Are there design guidelines for the homes proposed? Are there private garages which would negate the need for parking lots? Are there common parking areas for guests?
- Are the interior roads private?

Area B:

- To ensure the quality of these smaller cottage lots, we need to make sure that garages are set back, front porches are included, materials and design mimic cottage style homes similar to those in the Silo Square area.

Area C:

- Staff has no comment.

Area D:

- Tchulahoma Road will require some improvements in terms of a widened area for decel which needs to be studied and agreed upon by both staff and the applicant;

Area E:

- Minimum heated square footage has not been addressed.
- Design guidelines for driveways should be discussed.
- Mail accessibility (cluster? Is that needed or will we propose individual?)
- Is this the best option for this area? Do we want driveway traffic on a collector street between two other collector roadways?

Additional questions/comments for overall site:

- Fencing materials for the perimeter fence. Staff would like to see a more decorative design instead of the proposed six foot wood fence.
- Open space should be increased to meet the minimum 20% required by PUD zoned areas;
- The intersection of Nail Road and Tchulahoma Road will be highly visible, staff would like to see a landscape enhancement plan for the hard corner around the pond with or without subdivision signage.
- Parking pads for cluster mailboxes?
- Increased diversity of landscaping along perimeter where lots backyards are up against major roads.
- Tchulahoma Road portion will need to carry the existing pedestrian trail down the length of the Tchulahoma area and pick up where the Nail Road extension should incorporate it. The typical sections shown in the PUD booklet should revise to match.
- Nail Road typical section needs to be adjusted to match the typical section from city designers. The applicant will be responsible for the cost and/or build out of the northern portion of Nail Road (CL to property line) along the linear portion of the project. The typical sections shown in the PUD booklet should revise to match.
- The applicant has provided a plan that provides a good mixture of housing options

which take into account the surrounding areas and includes good transition areas from those existing developments. Prior to this plans submittal, the land was part of an overall PUD which was designed with cross access and a good internal flow of the street systems. The city required Silo Square to carry on that circulation and allow for road extensions to both the north and south development areas. That being said, this plan needs to acknowledge and address those points of access. Both area C and D have a stub out designed in Silo Square that is proposed to carry south into this development. While staff understands that both of these areas are gated, it will be required to provide this access. The applicant is welcome to look at different options on these connections to keep the gated community intact which could include incorporating the same gate system as the main entrance or providing a simple secured emergency access gate.

- The applicant will need to decide the accessibility of the gated areas so that the city can determine ownership of the roads. The AG handed down an opinion stating that any subdivision that restrict access with gates will own and maintain the roadways within the gated areas; however, if the gates were deemed “passive”, which allow traffic to pull up and the gates open without restriction, then the roads can be dedicated to the city for maintenance and repair. Staff is acceptable to either option but that will need to be determined at this point.

Staff believes the PUD to be a positive development which complies with the comprehensive plan and the overall concept for the area. Once the applicant addresses the above stated comments, staff recommends approval.



November 7, 2022

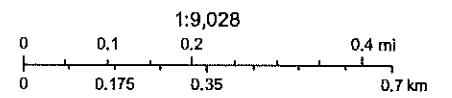

SERENITY POINTE PLANNED DEVELOPMENT



A FISHER ARNOLD
CONSULTANTS PLLC

6180 Cheatham Hills Drive | Memphis, Tennessee 38125-9638
901.344.1811 | Fax: 901.344.1719 | www.fisherarnold.com

PREPARED FOR:
SMJ ENTERPRISE
8275 TOURNAMENT DR, SUITE 100
MEMPHIS, TN 38125

SERENITY POINTE PLANNED DEVELOPMENT

CONTENTS

TABLE OF CONTENTS	1
DEVELOPMENT STATEMENT	2
EXISTING CONDITIONS	3
OUTLINE PLAN	4
CONCEPT PLAN	5
OUTLINE CONDITIONS	6
MASTER PLAN	7
LANDSCAPE PLATES 1 AND 2	8
LANDSCAPE PLATES 3 AND 4	9
LANDSCAPE PLATES 5 AND 6	10
LANDSCAPE PLATE 7 AND MAIL KIOSK ILLUSTRATION	11
DETAILS	12
ARCHITECTURAL STANDARDS (AREAS C AND D)	13
ARCHITECTURAL STANDARDS (AREAS C AND D)	14
ARCHITECTURAL STANDARDS (AREAS A AND B)	15

CONTENTS

SERENITY POINTE PLANNED DEVELOPMENT

Serenity Pointe PD DEVELOPMENT STATEMENT

Serenity Pointe Planned Development (Serenity Pointe PD) is the southwest portion of the previously recorded Snowden Farms Planned Development located between Goodman, Getwell, Nail and Tchulahoma Roads in Southaven, Mississippi. Current zoning is PUD, Planned Unit Development. The development standards created for Serenity Pointe PD reflect the those established in the original master development plan, and the proposed arrangement of development areas preserves a significant portion of the site's natural features. The intent of this Planned Development application is to modify the configuration of lot sizes and site circulation while maintaining the high standards established in the original PUD.

Serenity Pointe PD provides the opportunity to introduce Assited Living and Townhome / Condominium uses in Area A, adjacent to the Mixed-Use residential / retail uses approved for the parcel located just east of the development. The Assisted Living area is proposed for 7.14 acres, with a density of up to 12 dwelling units per acre (12 DU/AC). The Townhome / Condominium area is proposed for 6.70 acres, with a density of 6.86 DU/AC. The higher density of population in this area provides a transition between the retail uses along Getwell Road and the interior portions of the development. Access from Nail Road and circulation within this area is separated from the remainder of the development.

Area B, just west of Area A, provides a community of 98 single-family lots with a density of 3.47 DU/AC. This area also maintains a system of access drives separate from the remainder of the development, utilizing drives having a 50-foot right-of-way. The density and lot sizes for Area B are similar to the Cottage Lots in District 13, as established in the original PUD.

Area C, accessed from Tchulahoma Road, contains 138 single-family lots on 48.07 acres in a gated community setting. Its proposed density is 2.87 DU/AC, with internal circulation having a 31-foot right-of-way. A second gated community is found in Area D, with a total of 19 half-acre lots adjacent to Tchulahoma Road. This density reflects the intent of the original PUD's Grand Manor Lots in District 14B and also maintains 31-foot rights-of-way on its internal access drives.

Area E contains the largest lots, each 2 acres in area, which are provided access directly from the proposed extension of Nail Road.

Nail and Tchulahoma Roads are to be dedicated to 53 feet from center line, allowing for a future 106-foot right-of-way dedication. Internal access is to be public, with right-of-way widths of 31 and 50 feet. Access to the gated communities in Areas C and D will conform to Southaven's Ordinance in Chapter 4, Gated Communities.

Significant areas are set aside as Common Open Space, with the majority located along Lateral "F" of Horn Lake Creek. These common open spaces serve several functions. Although retention / detention areas are proposed for the development in these areas, allowing for more density of development, many of the existing trees are proposed to be retained, forming a park-like setting with natural features and walking trails connecting to the access drives of the surrounding communities. Retaining significant areas of natural features along Tchulahoma and Nail Roads provides preservation of the existing frontages, reflecting the character of the surrounding residential areas. The Common Open Spaces are to be owned and maintained by a Homeowners' Association.

Storm water will be managed by collecting site drainage and directing it to retention water features in Common Open Space A. A retention area at the southeast corner of the open space will provide a naturalistic water feature at the intersection of Tchulahoma and Nail Roads.

Architectural styles proposed for Snowden Farms PD are proposed to closely reflect the styles of the original Snowden Farms PUD and are shown in the photos included with this document.

SERENITY POINTE PLANNED DEVELOPMENT

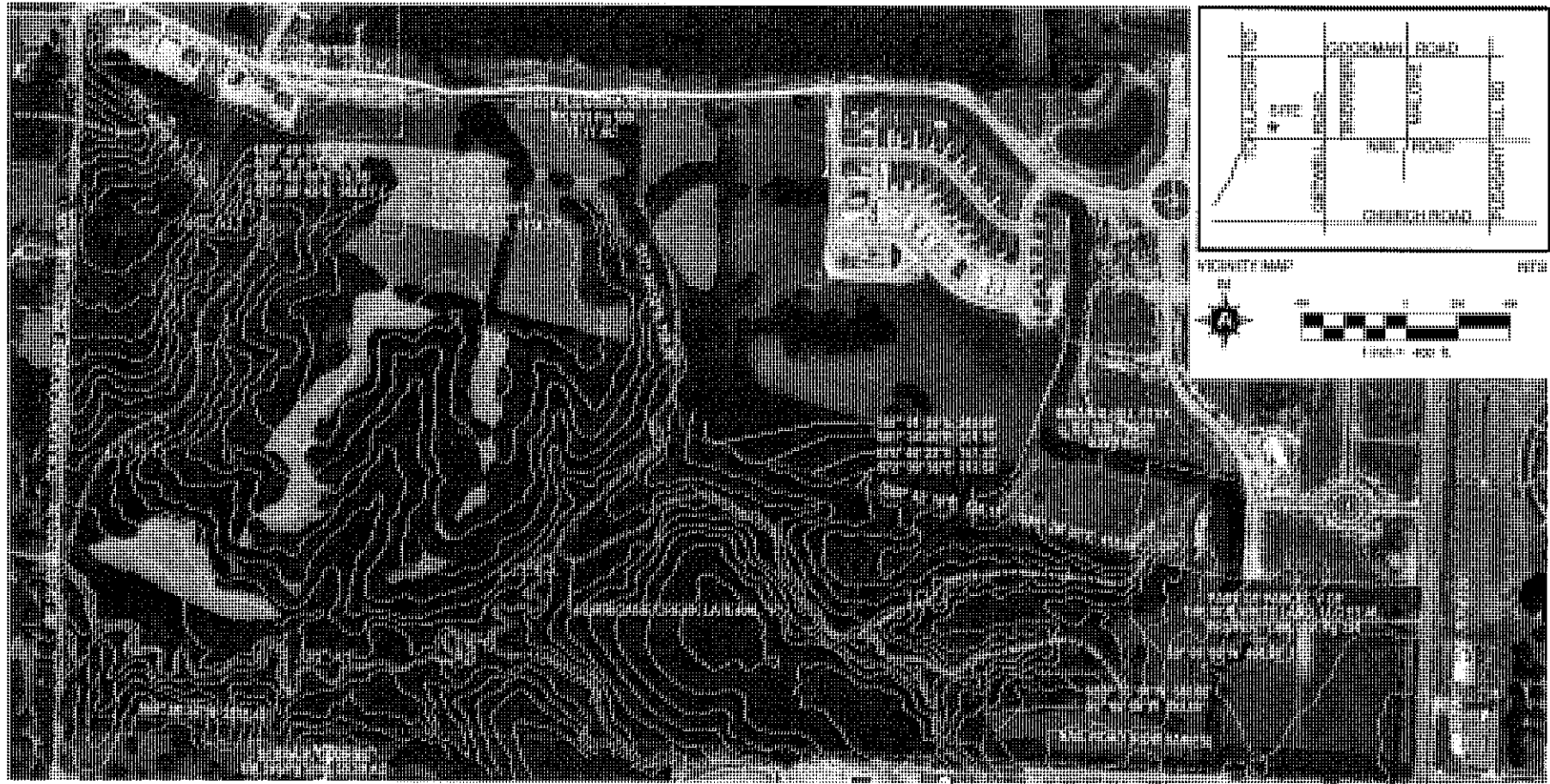

PROPERTY DESCRIPTION:

A 144.01 ACRE, MORE OR LESS, PARCEL OF LAND BEING PART OF THE SOUTH HALF OF SECTION 33, TOWNSHIP 1 SOUTH, RANGE 7 WEST, DESOTO COUNTY MISSISSIPPI, AND BEING MORE PARTICULARLY DESCRIBED AS FOLLOWS. Beginning at an iron pin found at the commonly accepted southwest corner of section 33, Township 1 South, Range 7 West, Desoto County Mississippi; thence with a bearing of N 00°13'22" W a distance of 2579.03 feet to a set iron pin; thence with a bearing of N 89°46'38" E a distance of 40.00 feet to a set iron pin; thence with a bearing of S 39°46'59" E a distance of 725.37 feet to a set iron pin; thence with a bearing of N 89°49'59" E a distance of 34.23 feet to a set iron pin; thence with a bearing of S 00°10'01" E a distance of 32.16 feet to a set iron pin; thence with a bearing of N 89°49'59" E a distance of 92.68 feet to a set iron pin; thence with a bearing of S 75°08'43" E a distance of 143.01 feet to a set iron pin; thence in an easterly direction with a non-tangent curve turning to the left with a radius of 1008.01 feet, having a chord bearing of N 84°49'05" E and a chord distance of 206.00, having a central angle of 11°43'47" and an arc length of 206.36 to a set iron pin; thence with a bearing of N 89°19'01" E a distance of 1174.77 feet to a set iron pin; thence with a bearing of S 17°34'14" E a distance of 769.16 feet to a set iron pin; thence with a bearing of S 67°01'39" E a distance of 245.98 feet to a set iron pin; thence with a bearing of S 81°34'20" E a distance of 201.19 feet to a set iron pin; thence with a bearing of S 74°46'22" E a distance of 157.30 feet to a set iron pin; thence with a bearing of S 72°09'36" E a distance of 212.52 feet to a set iron pin; thence with a bearing of S 90°42'10" E a distance of 566.13 feet to a set iron pin; thence with a bearing of S 78°26'00" E a distance of 416.94 feet to a set iron pin; thence with a bearing of S 00°06'06" W a distance of 464.28 feet to a set iron pin; thence with a bearing of N 89°53'54" W a distance of 540.00 feet to a set iron pin; thence with a bearing of S 00°06'06" W a distance of 353.00 feet to a set iron pin; thence with a bearing of N 89°34'29" W a distance of 1240.44 feet to a found 1/2" iron pin with no cap; thence with a bearing of S 89°58'39" W a distance of 2338.43 feet to the point of beginning.; containing 6272942.8 square feet or 144.01 acres more or less.

EXISTING CONDITIONS

SERENITY POINTE PLANNED DEVELOPMENT

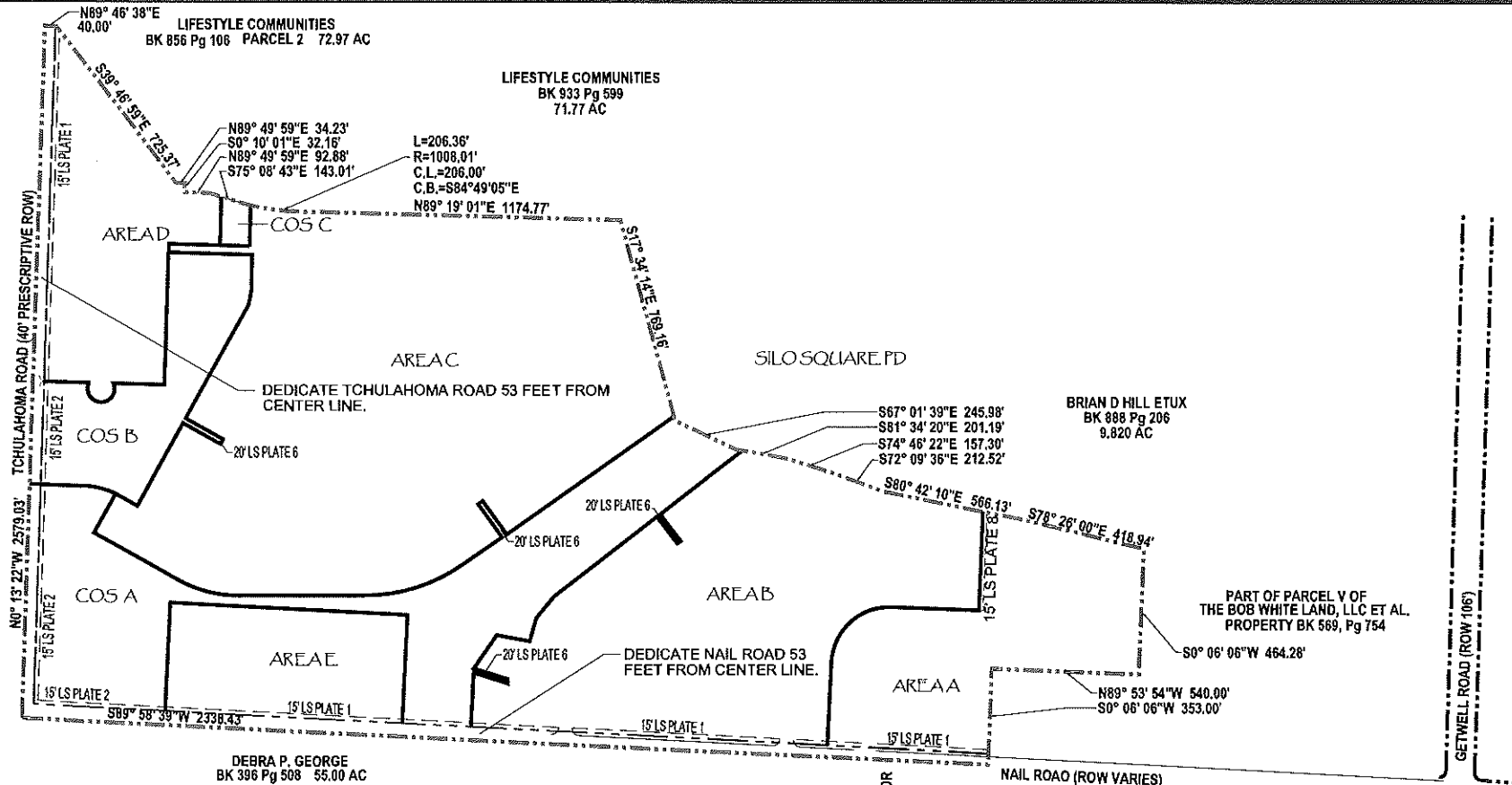

Plan Data

SITE GROSS ACREAGE: 144.01 ACRES - 6.96 ACRES DEDICATION = SITE NET ACREAGE 137.05 ACRES

RESIDENTIAL AREAS:

AREA A	ASSISTED LIVING	7.14 ACRES
AREA A	SINGLE FAMILY RESIDENTIAL	6.70 ACRES - 6.86 DU/AC
AREA B	SINGLE FAMILY RESIDENTIAL	28.27 ACRES - 3.47 DU/AC
AREA C	SINGLE FAMILY GATED RESIDENTIAL	48.07 ACRES - 2.87 DU/AC
AREA D	SINGLE FAMILY GATED RESIDENTIAL	10.91 ACRES - 0.82 DU/AC
AREA E	SINGLE FAMILY RESIDENTIAL	7.9 ACRES - 0.50 DU/AC
TOTAL RESIDENTIAL USES:		110.01 ACRES, 307 LOTS

OPEN SPACE AREAS:

COS A:	19.28 ACRES
COS B:	7.63 ACRES
COS C:	1.15 ACRES
COS WITHIN AREAS	.015 ACRES
TOTAL OPEN SPACE:	27.47 ACRES
(20% OF NET ACREAGE)	

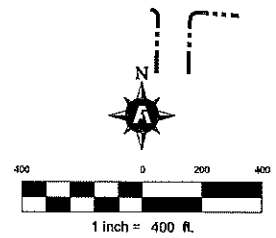

OUTLINE PLAN

SERENITY POINTE PLANNED DEVELOPMENT

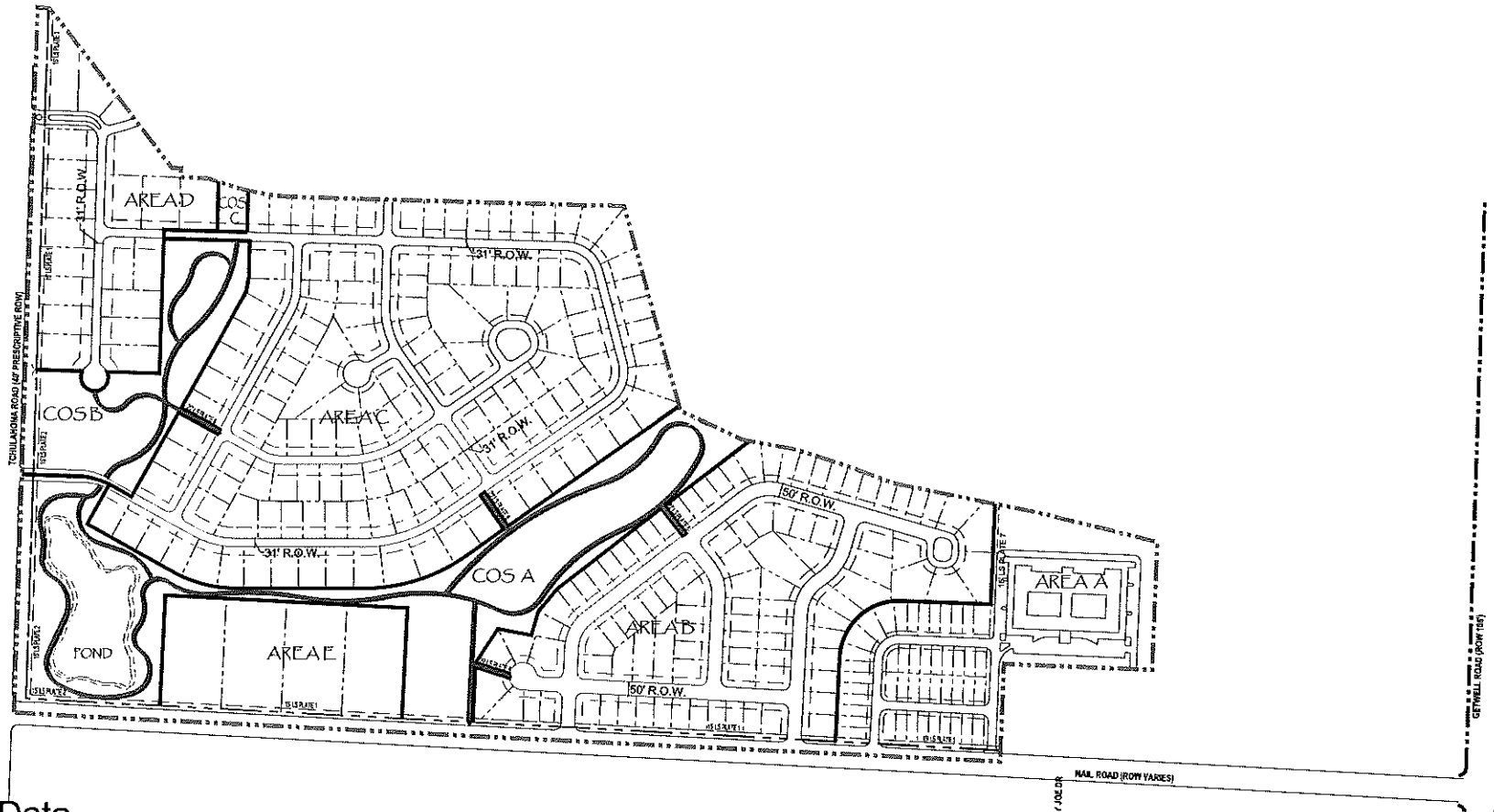

Plan Data

SITE GROSS ACREAGE: 144.01 ACRES - 6.96 ACRES DEDICATION = SITE NET ACREAGE 137.05 ACRES

RESIDENTIAL AREAS:

AREA A	ASSISTED LIVING	7.14 ACRES	
AREA A	SINGLE FAMILY RESIDENTIAL	6.70 ACRES - 6.86 DU/AC	46 - 40x125' LOTS
AREA B	SINGLE FAMILY RESIDENTIAL	28.27 ACRES - 3.47 DU/AC	98 - 50x125' LOTS
AREA C	SINGLE FAMILY GATED RESIDENTIAL	48.07 ACRES - 2.87 DU/AC	138 - 80x125' LOTS
AREA D	SINGLE FAMILY GATED RESIDENTIAL	10.91 ACRES - 0.82 DU/AC	19 -
AREA E	SINGLE FAMILY RESIDENTIAL	7.9 ACRES - 0.50 DU/AC	4 - 2 ACRE LOTS
TOTAL RESIDENTIAL USES:		110.01 ACRES, 307 LOTS	

OPEN SPACE AREAS:

COS A:	19.28 ACRES
COS B:	7.63 ACRES
COS C:	1.15 ACRES
COS WITHIN AREAS	.015 ACRES
TOTAL OPEN SPACE:	27.47 ACRES
	(20% OF NET ACREAGE)

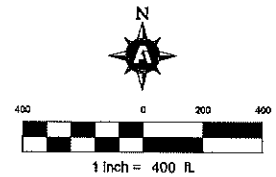

CONCEPT PLAN

SERENITY POINTE PLANNED DEVELOPMENT

SERENITY POINTE PLANNED DEVELOPMENT OUTLINE CONDITIONS

I. USES PERMITTED

- A. Area A: Single-Family Detached Residential, Single Family Attached/Townhome (age restricted) and Assisted Living Facility (RM-8 District) Uses shall be permitted as modified herein. No rental of units in Area is allowed and a note shall be included in the Home Owner Association Covenants and Restrictions.
- B. Area B: Single-Family Detached Residential Dwelling (RS-6 District) Uses shall be permitted as modified herein.
- C. Area C: Single-Family Detached Residential Dwelling (RS-10 District) Uses shall be permitted as modified herein.
- D. Area D: Single-Family Detached Residential Dwelling (RS-20 District) Uses shall be permitted as modified herein.
- E. Area E: Single-Family Detached Residential Dwelling (ER District) Uses shall be permitted as modified herein.

II. BULK REQUIREMENTS

- A. Maximum densities. Dwelling Units per acre for the overall Planned Development shall be 2.2 DU/AC or less.
- B. Area A will be subject to the City of Southaven Zoning Code and RM-8 District bulk requirements unless otherwise noted herein.
 - 1. Bulk regulations for Assisted Living Facility Uses shall be as follows:
 - a. Front yard setback: 60 feet minimum
 - b. Side yard setback: 15 feet minimum
 - c. Rear yard setback: 40 feet minimum
 - d. Maximum building height: 60 feet
 - e. Maximum density: 12 DU/AC
 - 2. Bulk Regulations for Single-Family Detached, Townhomes/Condominiums shall be as follows:
 - a. Front yard setback: 15 feet minimum
 - b. Side yard setback: 0 feet minimum for attached dwellings and 3.5 feet minimum for unattached dwellings
 - c. Rear yard setback: 20 feet minimum
 - d. Minimum lot area: 4,000 square feet
 - e. Minimum lot width: 30 feet
 - f. Maximum building height: 35 feet
 - e. Maximum density: 6 DU/AC
 - f. Minimum heated s.f. - Single Family 1,200
- C. Area B will be subject to the City of Southaven Zoning Code and R-6 District bulk requirements unless otherwise noted herein.
 - a. Front yard setback: 25 feet minimum
 - b. Side yard setback: 5 feet minimum
 - c. Rear yard setback: 25 feet minimum
 - d. Minimum lot area: 6,000 square feet
 - e. Minimum lot width: 50 feet
 - f. Maximum building height: 35 feet

D. Area C will be subject to the City of Southaven Zoning Code and R-10 District bulk requirements unless otherwise noted herein.

- a. Front yard setback: 40 feet minimum
- b. Side yard setback: 5 feet minimum
- c. Rear yard setback: 25 feet minimum
- d. Minimum lot area: 10,000 square feet
- e. Minimum lot width: 80 feet
- f. Maximum building height: 35 feet
- g. Minimum heated s.f. 2,800 s.f

E. Area D will be subject to the City of Southaven Zoning Code and R-20 District bulk requirements unless otherwise noted herein.

- a. Front yard setback: 40 feet minimum
- b. Side yard setback: 10 feet minimum
- c. Rear yard setback: 25 feet minimum
- d. Minimum lot area: 20,000 square feet
- e. Minimum lot width: 100 feet
- f. Maximum building height: 35 feet
- g. Minimum heated s.f. 3,000 s.f.

F. Area E will be subject to the City of Southaven Zoning Code and ER District bulk requirements unless otherwise noted herein.

- a. Front yard setback: 40 feet minimum
- b. Side yard setback: 15 feet minimum
- c. Rear yard setback: 25 feet minimum
- d. Minimum lot area: 2 acres
- e. Minimum lot width: 220 feet
- f. Maximum building height: 35 feet
- g. Minimum heated s.f. 3,000 s.f.

G. Air conditioning, heating and other mechanical equipment shall be screened using architectural features, plantings, fences, or other means from public rights-of-way and the site perimeter. Proposed screening shall be reviewed and approved by the Architectural Control Committee prior to installation.

III. ACCESS AND CIRCULATION

- A. Nail Road shall be dedicated and improved with curb, gutter, asphalt and a 10' wide multi-use trail per section B S-1, forty-one (41) feet from the center line.
- B. Tchulahoma Road shall be dedicated and improved with curb, gutter, asphalt and a 10' wide multi-use trail per section B S-1, forty-one (41) feet from the center line.
- C. All internal public streets shall be dedicated and improved in accordance with the Streetscape Plates provided herein.

IV. LANDSCAPING

- A. Streetscape areas along Nail Road shall be a minimum fifteen (15) feet in width, Plate 1.
- B. Streetscape areas along Tchulahoma Road shall be a minimum fifteen (15) feet

C. Streetscape areas along internal roadways shall be a minimum of ten (10) feet in width from back of curb, Landscape Plates 3, 4, and 5.

D. Proposed public trails shall be provided adequate landscaped areas and clearances, Landscape Plate 7.

E. Common open space areas, including trees in said areas, shall be owned and maintained by the Owner's Association.

F. Irrigation of all trees and landscaped areas shall be required.

G. Alternative landscape designs equivalent to the approved Master Development Plan may be considered at the time of the review of the Design Review Committee.

H. All utility transformers and telephone pedestals shall be located at least twelve (12) feet from the right-of-way unless site-specific conditions dictate an alternative location.

I. To further enhance the neighborhood / community setting of the Development, a premium will be placed on the preservation of the natural tree cover and other unique characteristics of the landscape. This is deemed necessary in order to maintain a sense of natural amenity and to preserve the intrinsic environmental values and continuity of mature, native tree cover as a wildlife habitat and as protection against erosion and contamination by runoff on the site. Conceptual site plans shall include a tree survey of all specimen-quality trees on the site. All free-standing trees with a trunk diameter of eight (8) inches or more as measured four and one-half (4 1/2) feet above grade shall be preserved if at all possible. Particular attention shall be given to grade changes and other work within the drip line of trees to be preserved. Grading, drainage and aeration shall be maintained within the drip line of trees to be preserved.

SERENITY POINTE PLANNED DEVELOPMENT



Plan Data

SITE TOTAL ACRES: 14.01 ACRES - 0.00 ACRES (CONCRETE) - SITE NET ACRES: 13.01 ACRES

RESIDENTIAL AREAS:

AREA A	ASSISTED LIVING	2.04 ACRES
AREA A	SINGLE FAMILY RESIDENTIAL	6.70 ACRES - 0.00 (CONC) - 66 - 60'x80' LOTS
AREA B	SINGLE FAMILY RESIDENTIAL	0.07 ACRES - 0.07 (CONC) - 00 - 60'x80' LOTS
AREA C	SINGLE FAMILY GATED RESIDENTIAL	0.07 ACRES - 0.00 (CONC) - 00 - 60'x80' LOTS
AREA D	SINGLE FAMILY GATED RESIDENTIAL	0.01 ACRES - 0.00 (CONC) - 00 -
AREA E	SINGLE FAMILY RESIDENTIAL	0.00 ACRES - 0.00 (CONC) - 0 - 0 ACRES LOTS
TOTAL RESIDENTIAL LOTS: 66		

OTHER AREAS:

CODE A:	10.00 ACRES
CODE B:	1.00 ACRES
CODE C:	0.00 ACRES
CODE WITHIN AREAS:	0.00 ACRES
TOTAL OPEN SPACE:	07.07 ACRES (53% OF NET ACRES)



1 inch = 100 ft.

SERENITY POINTE PLANNED DEVELOPMENT

SERENITY POINTE PLANNED DEVELOPMENT

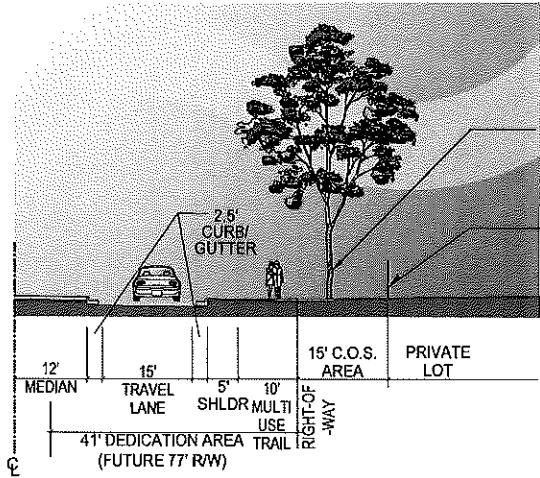

DECIDUOUS CANOPY TREE, 40' O.C. MAXIMUM
O/H WIRES: UNDERSTORY TREE, 30' O.C. MAXIMUM

6' PRIVACY FENCE AT COMMON OPEN SPACE

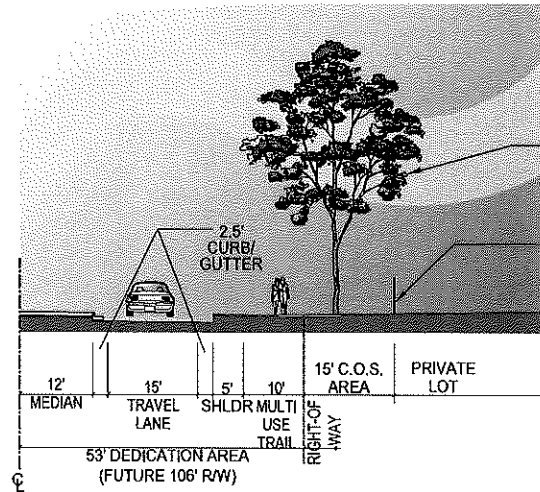

DECIDUOUS CANOPY TREE, 40' O.C. MAXIMUM
O/H WIRES: UNDERSTORY TREE, 30' O.C. MAXIMUM

6' DECORATIVE METAL PICKET FENCE WITH BRICK COLUMNS, MAXIMUM 50' O.C.

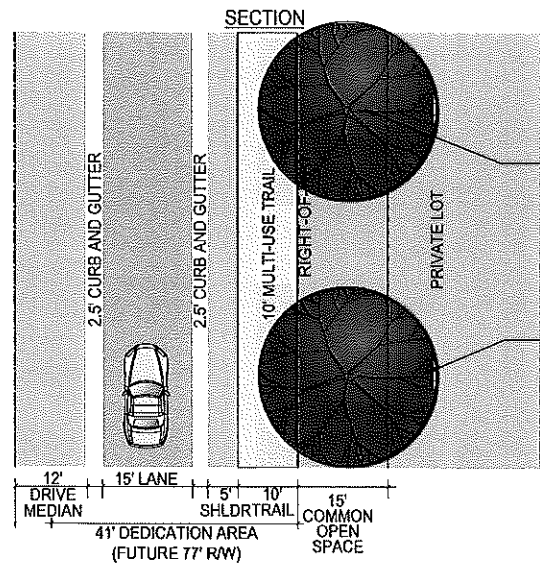

DECIDUOUS CANOPY TREE, 40' O.C. MAXIMUM
O/H WIRES: UNDERSTORY TREE, 30' O.C. MAXIMUM

6' PRIVACY FENCE

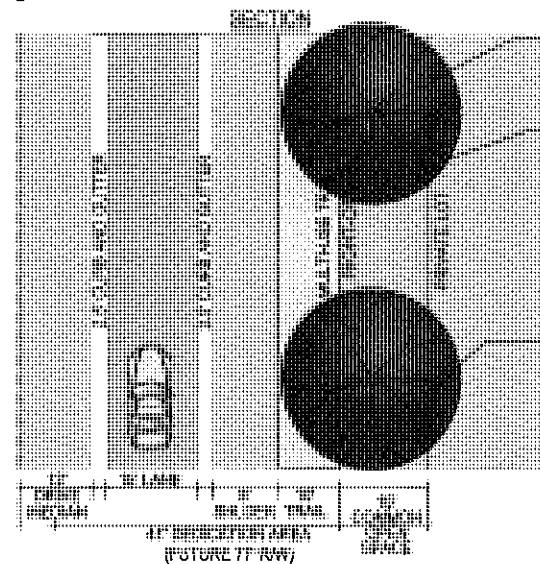

DECIDUOUS CANOPY TREE, 40' O.C. MAXIMUM
O/H WIRES: UNDERSTORY TREE, 30' O.C. MAXIMUM

2'X2' BRICK COLUMNS, 50' O.C. MAX., TO MATCH REMAINING ENTRY FEATURES

6' DECORATIVE METAL PICKET FENCE, TYPICAL

LANDSCAPE PLATE 1

N.T.S.

LANDSCAPE PLATE 2

N.T.S.

LANDSCAPE PLATES 1 AND 2

SERENITY POINTE PLANNED DEVELOPMENT

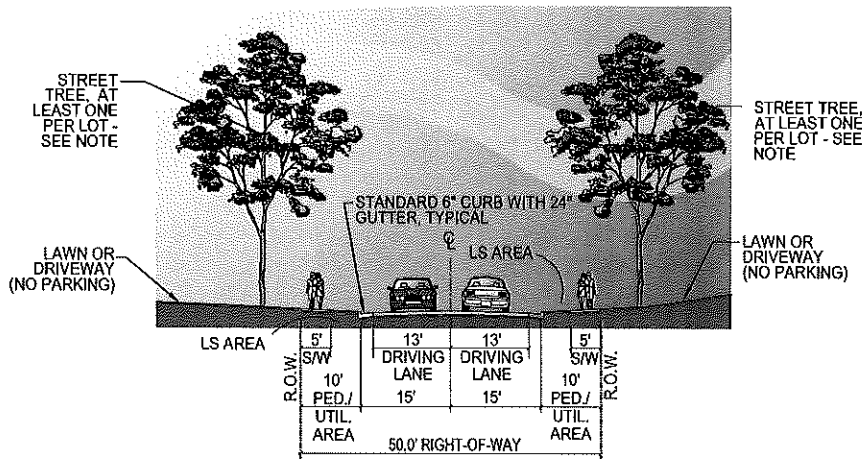

SECTION

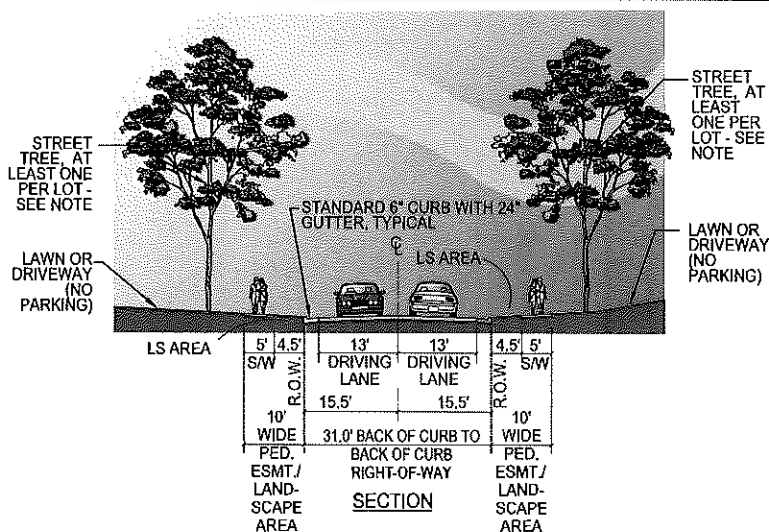

SECTION

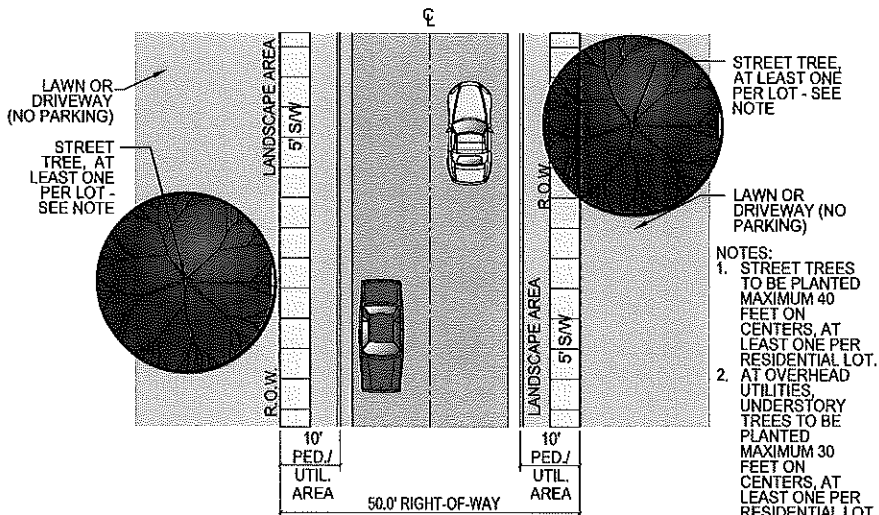

PLAN

LANDSCAPE PLATE 3

N.T.S.

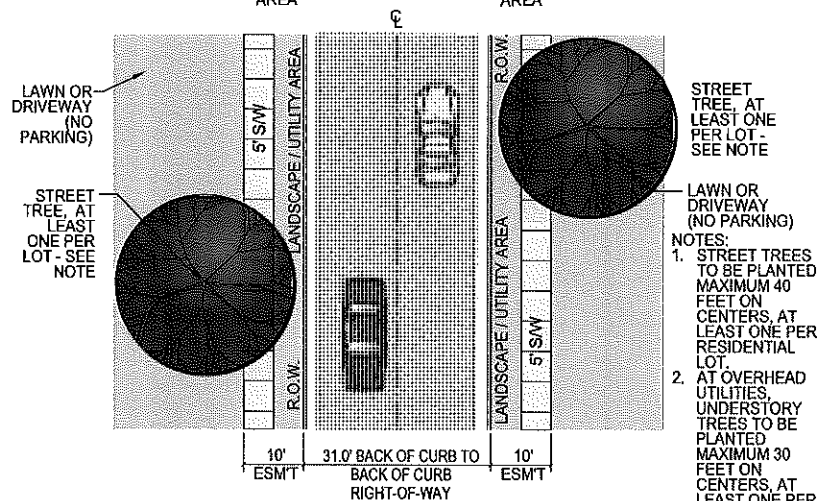

PLAN

LANDSCAPE PLATE 4

N.T.S.

LANDSCAPE PLATES 3 AND 4

SERENITY POINTE PLANNED DEVELOPMENT

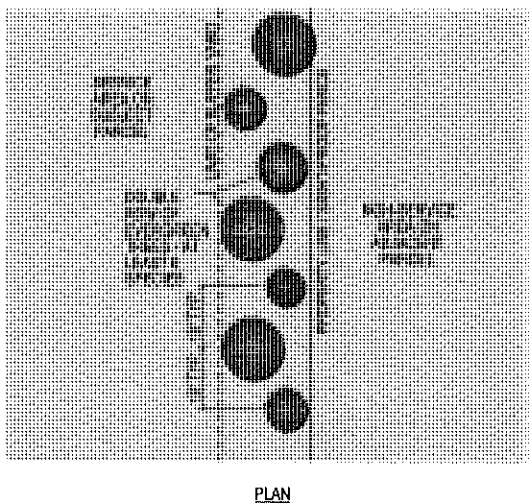
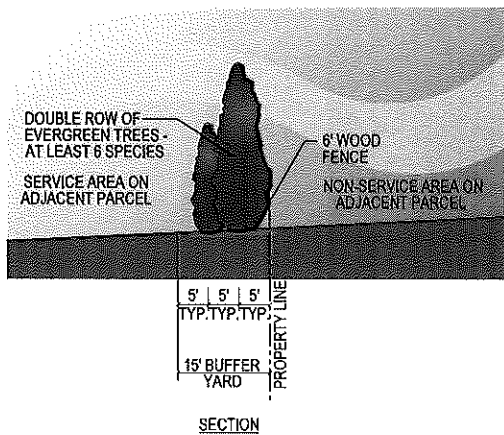

LANDSCAPE PLATE 7

N.T.S.



Example of proposed cluster mailbox treatment.

SERENITY POINTE PLANNED DEVELOPMENT

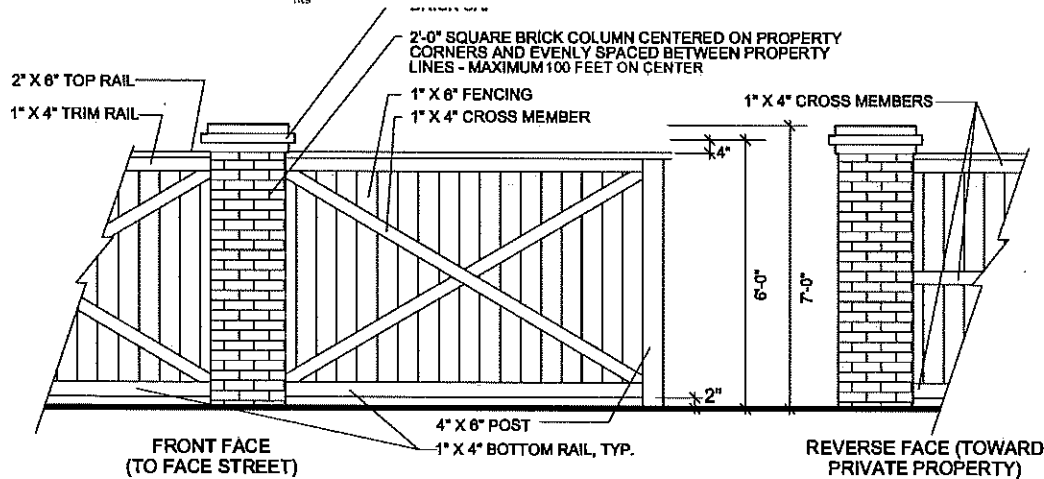
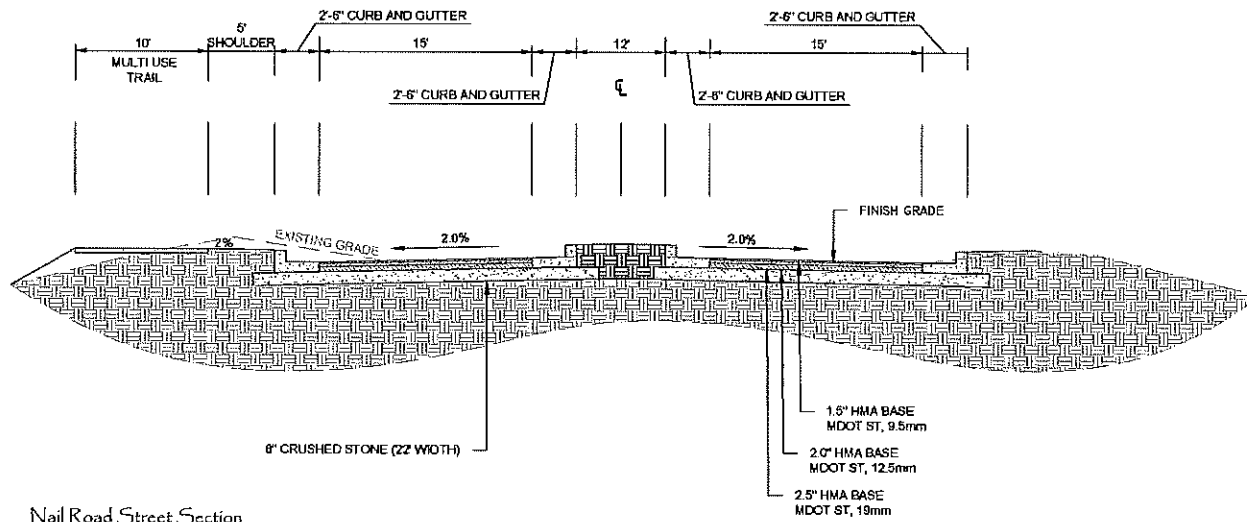

- NOTES:**
1. ALL WOOD SHALL BE STAINED WITH OLYMPIC BRAND EXTERIOR SEMI-SOLID "RUSTIC CEDAR" OR EQUIVALENT.
 2. BOTTOM OF WOOD FENCING SHALL BE 2" ABOVE FINISH GRADE
 3. WOOD POSTS TO BE EQUALLY SPACED BETWEEN COLUMNS, MAX. 8'-0" O.C.
 4. CROSS-MEMBERS, TOP RAILS, AND BOTTOM RAILS ON FENCE TO FACE OUTWARD, TOWARD STREET.

6-FOOT PRIVACY FENCE DETAIL

Privacy Fence Detail

SERENITY POINTE PLANNED DEVELOPMENT

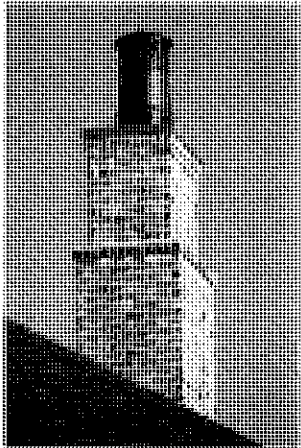

Design Integrity:

Maintaining architectural harmony will give *Serenity Pointe* its unique character and will ensure that the beauty and spirit of its streetscapes and natural environment provide a neighborhood of lasting value and timeless grace. *Serenity Pointe* is more than just another subdivision. It will be crafted and influenced by a desire to recreate those principled experiences and places of our past which lifted the spirit and spoke to the soul. It is a new community which is patterned after the rich, traditional vernacular of the local area and will seek to create special places and experiences that strengthen the individual, family, and community.

Architectural Standards:

All new construction shall be designed using a traditional approach to both massing and material detailing. The design tradition appropriate for *Serenity Pointe* has its precedence in the "Southern vernacular" and/or "European" styles.

Written design guidelines and a plans / design review process will be put in place to strengthen the aesthetic character of *Serenity Pointe*. This process will help ensure that the homes designed and built in *Serenity Pointe* are compatible with the historic architectural context and craftsmanship of this region. It will also encourage an elegant simplicity in the approved architectural styles in which quality of detail and materials is emphasized. In addition, it will promote a sense of coherence and order in the built environment.

The goal is to promote creative design solutions while ensuring compatible design character throughout the development. It is the responsibility of each homeowner, architect, designer, and builder to become familiar with, and understand, the Design Guidelines prior to submitting plans for approval. Only those design solutions which adhere to the Design Guidelines and development theme will be approved by the Design Review Committee (DRC).



SERENITY POINTE PLANNED DEVELOPMENT

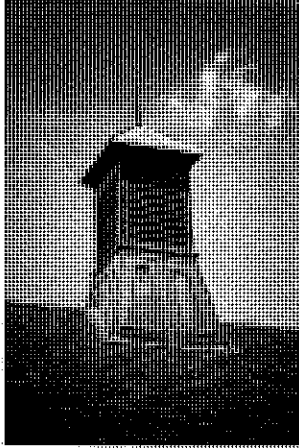

ARCHITECTURAL STANDARDS

SERENITY POINTE PLANNED DEVELOPMENT

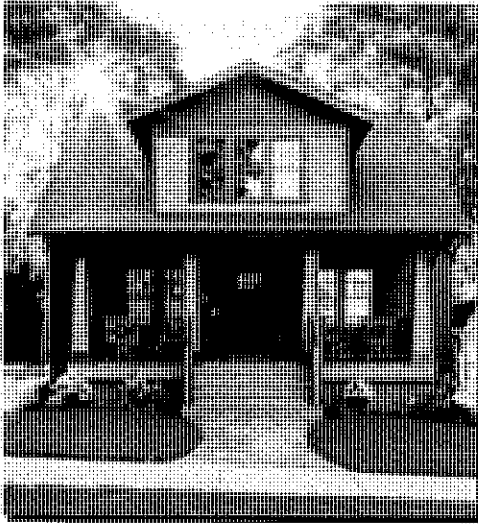

Cottage Lot Residential Style
nts



Single Family Residential Style
nts



ARCHITECTURAL STANDARDS

VIA E-MAIL

Gardens of Belle Pointe Homeowners Association, Inc.

Re: Amended Covenants

To Whom it May Concern:

On behalf of the City of Southaven ("City"), I have received notice that the Gardens of Belle Point Homeowners Association, Inc.'s ("Association") Declaration of Covenants, Conditions, and Restrictions ("CCR") dated November 24, 2018 filed at Book 874, Page 99, require the approval of the City for any amendments. As you know, the Association's CCR is a private contract between the subdivision residents and Association, and the City, as a governmental entity, has no legal authority to enforce or regulate the Association's CCR. Thus, the City does not typically have a role in the approval of amended homeowner association covenants. However, based on the Association's CCR Article XVI, to the extent the City's approval is required, the City does not object to the proposed amendment by the Association to the CCR.

The City shall not enforce any of the Association's CCR and all such enforcement shall be by the Association. This correspondence shall not be construed as the City opining to the enforceability or legality of the Association's CCR or proposed amendment. Finally, as the Association's CCR is a private contract between the subdivision residents and Association, the City respectfully requests that the requirement that the City approve any amendments be deleted.

If you should have any questions, please feel free to call me.

Sincerely,

Whitney Cook
Southaven Planning Director



The City of Southaven Docket Recap December 20, 2022

General Fund		2,238,852.90
Balance Sheet	624.11	
Mayor Admin	142.50	
Board of Aldermen	-	
Arts And Cultural Affairs	1,366.00	
Court	175,155.55	
Finance & Administration	249.73	
Information Technology	57,314.42	
City Clerk	3,813.45	
Operations Department	9,135.93	
Planning & Engineering	35,331.95	
Emergency Services	2,324.05	
Police	140,619.26	
Fire	29,493.09	
Fire Prevention	1,571.47	
EMS	26,811.84	
Public Works	229,103.02	
Streets	4,724.02	
Parks	130,065.73	
Park Tournaments	5,841.47	
Code Enforcement	2,169.84	
City Fuel	-	
Expense Accounts	1,015,164.37	
Administrative Expenses	-	
Litigation	27,679.10	
Liability Insurance	320,152.00	
Professional Dues	20,000.00	
Bond Funded CAP Proj		353,606.23
Tourist & Convention		141,343.90
Debt Service		-
Utility Fund		553,977.61
Sanitation Fund		285,806.60
Payroll Fund		628,651.20
DOCKET TOTAL		4,202,238.44

12/15/2022 12:59
1540spri

CITY OF SOUTHAVEN
FY 2023 CLAIMS DOCKET C-122022

P 1
apinvgl

YEAR/PERIOD: 2023/1	TO 2023/3									
ACCOUNT/VENDOR	INVOICE	PO	YEAR/PR	TYP	S	WARRANT	CHECK	DESCRIPTION		
111			MAYOR ADMIN DEPARTMENT							
111	610400		OFFICE SUPPLIES							
004975	BAREFIELD WORKPLACE	1164049	0	2023	3 INV A	4.50	C-122022	23 CALENDARS & OFFI		
					ACCOUNT TOTAL	4.50				
111	626900		TRAVEL & TRAINING							
020340	MUSSELWHITE DARREN	12-14-2022	0	2023	3 INV A	138.00	C-122022	2023 MML WINTER CON		
					ACCOUNT TOTAL	138.00				
					ORG 111 TOTAL	142.50				
120			ARTS AND CULTURAL AFFAIRS							
120	622100		PROFESSIONAL FEES							
004489	JOHNSON CINDY	245-22	0	2023	3 INV A	630.00	C-122022	AEROBIC CLASS (NOV.		
013302	MCMULLIN GLORIA	11-2022	0	2023	3 INV A	120.00	C-122022	LINE DANCE - NOV. 2		
021019	CAIN LINDA A	1128-22	0	2023	3 INV A	60.00	C-122022	LINE DANCE INSTR. (
021019	CAIN LINDA A	125-22	0	2023	3 INV A	60.00	C-122022	LINE DANCE CLASS (3		
						120.00				
028876	BURCH DEBORA	1129-22	0	2023	3 INV A	270.00	C-122022	YOGA CLASS (NOV. 1,		
034218	SMITH DEBORAH E	1206-22	0	2023	3 INV A	30.00	C-122022	CHAIR YOGA (DEC. 6,		
					ACCOUNT TOTAL	1,170.00				
					ORG 120 TOTAL	1,170.00				
125			COURT DEPARTMENT							
125	621500		COURT BOND REFUND							
033916	HEROD QUINTON	12-13-2022	0	2023	3 INV A	300.00	C-122022	CASH BOND REFUND		
035152	OLGUIN MIGUEL BARRON	11-30-2022	0	2023	3 INV A	150.00	C-122022	CASH BOND REFUND		
036746	RIDGWAY TIMOTHY E	11-30-2022	0	2023	3 INV A	160.00	C-122022	CASH BOND REFUND		
036747	JOHNSON JASMINE C	11-30-2022	0	2023	3 INV A	150.00	C-122022	CASH BOND REFUND		
036748	STRIBLING TIMOTHY	11-30-2022	0	2023	3 INV A	297.00	C-122022	CASH BOND REFUND		
036749	HAMLETT JERRY A	11-30-2022	0	2023	3 INV A	30.00	C-122022	CASH BOND REFUND		
036750	ARREGOITIA JOSE	11-30-2022	0	2023	3 INV A	100.00	C-122022	CASH BOND REFUND		
036751	BOYD WILLIAM R	11-30-2022	0	2023	3 INV A	150.00	C-122022	CASH BOND REFUND		
036752	VERNON JAMES N	12-6-2022	0	2023	3 INV A	200.00	C-122022	CASH BOND REFUND		

12/15/2022 12:59
1540spri

CITY OF SOUTHAVEN
FY 2023 CLAIMS DOCKET C-122022

P 2
apinvgl

YEAR/PERIOD: 2023/1 ACCOUNT/VENDOR	TO 2023/3 INVOICE	PO	YEAR/PR	TYP	S	WARRANT	CHECK	DESCRIPTION
036753 CLARK DERRICK D	12-7-2022	0	2023 3	INV	A	150.00 C-122022		CASH BOND REFUND
036754 WILLIS IZELL D	12-7-2022	0	2023 3	INV	A	93.00 C-122022		CASH BOND REFUND
036755 STRONG CHRISTOPHER	12-7-2022	0	2023 3	INV	A	150.00 C-122022		CASH BOND REFUND
036756 GREEN BRENDA H	12-7-2022	0	2023 3	INV	A	250.00 C-122022		CASH BOND REFUND
036826 ABIMAEV V HERNANDEZ	12-13-2022	0	2023 3	INV	A	100.00 C-122022		CASH BOND REFUND
ACCOUNT TOTAL						2,280.00		
125 621501			COURT FINES					
000955 STATE TREASURER	12-1-2022	0	2023 3	INV	A	154,523.45 C-122022		DEC. 2022 STATE ASS
000962 CRIME STOPPERS	12-1-2022	0	2023 3	INV	A	2,290.15 C-122022		DEC. 2022 CRIME STO
000963 DEPT OF PUBLIC SAFET	12-1-2022	0	2023 3	INV	A	8,990.72 C-122022		DEC. 2022 I.W.R.C.P
000963 DEPT OF PUBLIC SAFET	12-1-22	0	2023 3	INV	A	4,313.36 C-122022		DEC. 2022 IGNITION
						13,304.08		
024253 AMERICAN MUNICIPAL S	55340	0	2023 3	INV	A	140.95 C-122022		COLLECTION FEES - O
029524 MISSISSIPPI FORENSIC	12-1-2022	0	2023 3	INV	A	50.00 C-122022		DEC. 2022 CRIME LAB
ACCOUNT TOTAL						170,308.63		
125 621505			COURT SUPPLIES					
004975 BAREFIELD WORKPLACE	1164049	0	2023 3	INV	A	18.00 C-122022		23 CALENDARS & OFFI
007600 ODP BUSINESS	276068683001	0	2023 3	INV	A	51.67 C-122022		OFFICE SUPPLIES
007823 AMERICAN PAPER & TWI	4506842	0	2023 3	INV	A	568.00 C-122022		COPY PAPER
014117 MADISON SIGNS LLC	16248	0	2023 3	INV	A	475.00 C-122022		CONTINUANCE ORDERS
ACCOUNT TOTAL						1,112.67		
125 622100			PROFESSIONAL SERVICES					
029556 PATEL HITEN H	12-2-2022	0	2023 3	INV	A	200.00 C-122022		SPECIAL PROSECUTOR
029556 PATEL HITEN H	12-7-2022	0	2023 3	INV	A	200.00 C-122022		SPECIAL PROSECUTOR
						400.00		
030970 VICKERS COLE	12-2-2022	0	2023 3	INV	A	200.00 C-122022		SPECIAL PROSECUTOR
033114 DALTON MATTHEW G	11-30-2022	0	2023 3	INV	A	200.00 C-122022		PUBLIC DEFENDER - N
034072 LAW OFFICE OF TOMMY	11-30-2022	0	2023 3	INV	A	200.00 C-122022		SPECIAL JUDGE - NOV
036633 JORDAN RUSSELL	12-09-22	0	2023 3	INV	A	200.00 C-122022		SPECAIL PROSECUTOR-

12/15/2022 12:59
1540spri

CITY OF SOUTHAVEN
FY 2023 CLAIMS DOCKET C-122022

P 3
apinvgl

YEAR/PERIOD:	2023/1	TO	2023/3	ACCOUNT/VENDOR	INVOICE	PO	YEAR/PR	TYP	S	WARRANT	CHECK	DESCRIPTION	
ACCOUNT TOTAL										1,200.00			
ORG 125 TOTAL										174,901.30			
145													
145	610400												
	004975	BAREFIELD WORKPLACE	1164049		0		2023	3	INV A		33.54	C-122022	23 CALENDARS & OFFI
	007600	ODP BUSINESS	278479344001		0		2023	3	INV A		102.76	C-122022	INK
	030629	AMAZON CAPITAL	1LHJDCWFD1VX		0		2023	3	INV A		5.43	C-122022	#ANKP067K88KPB-DYMO
ACCOUNT TOTAL										141.73			
ORG 145 TOTAL										141.73			
150													
150	610500												
	000342	DELL MARKETING LP	10634572148		23000072		2023	3	INV A		24,849.75	C-122022	25 DELL DESKTOP COM
	000739	CDW LLC	FL03953		0		2023	3	INV A		2,659.80	C-122022	MONITORS
	019694	MID-SOUTH TELECOM	75234		0		2023	3	INV A		133.98	C-122022	PROX CARDS
	024507	MONOPRICE INC	23112791		0		2023	3	INV A		56.99	C-122022	WALL PLATE COVERS
	026785	BEST BUY	6665539		0		2023	3	INV A		19.99	C-122022	DVD WRITER
	030629	AMAZON CAPITAL	1CJFDH3RQ4RM		0		2023	3	INV A		5.95	C-122022	#ANKP067K88KPB-TELE
	030629	AMAZON CAPITAL	1FXW6NX9RN1T		0		2023	3	INV A		820.15	C-122022	#ANKP067K88KPB-VIDE
	030629	AMAZON CAPITAL	1R4RCWP9P9V4		0		2023	3	INV A		52.36	C-122022	#ANKP067K88KPB-STER
										878.46			
	036581	METROLINE INC	1052441		0		2023	3	INV A		169.75	C-122022	REPLACEMENT AVAYA P
	036581	METROLINE INC	1052758		0		2023	3	INV A		49.70	C-122022	HANDSET REPLACEMENT
										219.45			
ACCOUNT TOTAL										28,818.42			
150	610550												
	000952	TYLER TECHNOLOGIES	45-399726		0		2023	3	INV A		12,301.01	C-122022	QUARTERLY PAYMENT (
ACCOUNT TOTAL										12,301.01			
150	614000												
	006919	FUELMAN	NP62714311		0		2023	3	INV A		138.97	C-122022	#BG2241616 - IT FUE
	006919	FUELMAN	NP63330541		0		2023	3	INV A		53.54	C-122022	#BG2241616 - IT FUE
	006919	FUELMAN	NP63410013		0		2023	3	INV A		117.03	C-122022	#BG2241616 - IT FUE
	006919	FUELMAN	NP63454553		0		2023	3	INV A		85.78	C-122022	#BGF2241616 - IT FU

12/15/2022 12:59
1540spri

CITY OF SOUTHAVEN
FY 2023 CLAIMS DOCKET C-122022

P 4
apinvgl

YEAR/PERIOD: 2023/1 TO 2023/3								
ACCOUNT/VENDOR	INVOICE	PO	YEAR/PR	TYP S	WARRANT	CHECK	DESCRIPTION	
								395.32
							ACCOUNT TOTAL	395.32
150	626900						TRAVEL & TRAINING	
025176	CBT NUGGETS LLC	2882392	0	2023 3	INV A			3,594.00 C-122022
								LEAMER IT TRAINING
							ACCOUNT TOTAL	3,594.00
			ORG 150	TOTAL				45,108.75
155							CITY CLERK	
155	610400						OFFICE SUPPLIES	
007600	ODP BUSINESS	263808667001	0	2023 3	CRM A			-5.99 C-122022
007600	ODP BUSINESS	278030168001	0	2023 3	INV A			208.30 C-122022
								202.31
							ACCOUNT TOTAL	202.31
155	610401						OFFICE SUPPLY-INVENTORY	
004975	BAREFIELD WORKPLACE	1164049	0	2023 3	INV A			57.76 C-122022
								23 CALENDARS & OFFI
007600	ODP BUSINESS	277119265001	0	2023 3	INV A			107.41 C-122022
								INVENTORY SUPPLIES
007823	AMERICAN PAPER & TWI	4500962	0	2023 3	INV A			340.80 C-122022
								COPY PAPER & JANITO
030629	AMAZON CAPITAL	1LHJDCWFD1VX	0	2023 3	INV A			40.81 C-122022
								#ANKP067K88KPB-DYMO
							ACCOUNT TOTAL	546.78
155	622100						PROFESSIONAL SERVICES	
016013	CIVICPLUS	235853	0	2023 3	INV A			1,399.12 C-122022
016013	CIVICPLUS	246685	0	2023 3	INV A			44.16 C-122022
								1,443.28
029120	YOUNG LEASING CO	INV6037507	0	2023 3	INV A			244.71 C-122022
029120	YOUNG LEASING CO	INV6061779	0	2023 3	INV A			242.35 C-122022
								487.06
							ACCOUNT TOTAL	1,930.34
155	626900						TRAVEL & TRAINING	
016889	CENTER FOR GOVERN	11-18-2022	0	2023 3	INV A			200.00 C-122022
								CMC PROGRAM SESSION
							ACCOUNT TOTAL	200.00
			ORG 155	TOTAL				2,879.43

12/15/2022 12:59
1540spr

CITY OF SOUTHAVEN
FY 2023 CLAIMS DOCKET C-122022

P 5
apinvgl

YEAR/PERIOD: 2023/1 TO 2023/3										
ACCOUNT/VENDOR	INVOICE	PO	YEAR/PR	TYP	S	WARRANT	CHECK	DESCRIPTION		
BUILDING DEPARTMENT										
160	610400		OFFICE SUPPLIES							
007823	AMERICAN PAPER & TWI	4500962	0	2023	3	INV	A	50.70	C-122022	COPY PAPER & JANITO
016050	HENRY SCHEIN INC	24895319	0	2023	3	INV	A	178.21	C-122022	MEDICAL OFFICE SUPP
030629	AMAZON CAPITAL	19HRLCWV13XD	0	2023	3	INV	A	78.42	C-122022	#ANKP067K88KPB-OFFI
ACCOUNT TOTAL								307.33		
160	611000		MATERIALS							
000457	GRAINGER	9513045568	0	2023	3	INV	A	1,425.54	C-122022	NEW WATER BOTTLE FI
000457	GRAINGER	9515373067	0	2023	3	INV	A	18.03	C-122022	FS #2 - FOUCET REPA
								1,443.57		
000734	MAGNOLIA ELECTRIC	358065	0	2023	3	INV	A	237.41	C-122022	MATERIALS FOR CITY
000734	MAGNOLIA ELECTRIC	359450	0	2023	3	INV	A	898.86	C-122022	ARCHIVE AREA TRACK
000734	MAGNOLIA ELECTRIC	360986	0	2023	3	INV	A	33.85	C-122022	TOOLS
000734	MAGNOLIA ELECTRIC	361605	0	2023	3	INV	A	1,043.52	C-122022	ELECTRIC STOCK AND
000734	MAGNOLIA ELECTRIC	361754	0	2023	3	INV	A	403.45	C-122022	LED BULBS FOR TRAFF
								2,617.09		
001104	SHERWIN WILLIAMS SOU	591-9	0	2023	3	INV	A	276.90	C-122022	PAINT MAT.
001104	SHERWIN WILLIAMS SOU	9477-2	0	2023	3	INV	A	65.13	C-122022	MATERIALS (PI DTM E
								342.03		
028212	UNITED REFRIGERATION	87676789	0	2023	3	INV	A	437.50	C-122022	MATERIALS
028212	UNITED REFRIGERATION	87793904	0	2023	3	INV	A	159.33	C-122022	MATERIALS
028212	UNITED REFRIGERATION	87795088	0	2023	3	INV	A	20.13	C-122022	MATERIALS
028212	UNITED REFRIGERATION	87821323	0	2023	3	INV	A	217.85	C-122022	MATERIALS
								834.81		
ACCOUNT TOTAL								5,237.50		
160	612500		UNIFORMS							
010919	TRACTOR SUPPLY CREDI	300254485	0	2023	3	INV	A	121.98	C-122022	UNIFORMS (COAT & HA
031112	BRINK DYLAN	12-2-2022	0	2023	3	INV	A	100.00	C-122022	REIMB. FOR \$100 TOW
ACCOUNT TOTAL								221.98		
160	622100		PROFESSIONAL SERVICES							
001099	NORTH MS PEST CONTRO	132-01248924	0	2023	3	INV	A	545.00	C-122022	8710 NORTHWEST DRIV
001099	NORTH MS PEST CONTRO	132-01249527	0	2023	3	INV	A	40.00	C-122022	1855 VETERANS DR -
								585.00		

12/15/2022 12:59
1540spr1

CITY OF SOUTHAVEN
FY 2023 CLAIMS DOCKET C-122022

P 6
apinvgl

YEAR/PERIOD: 2023/1 TO 2023/3	ACCOUNT/VENDOR	INVOICE	PO	YEAR/PR	TYP	S	WARRANT	CHECK	DESCRIPTION
	008127	WASTE CONNECTIONS OF 6739537W010	0	2023	3	INV A	432.38	C-122022	6010-1142267/@ 7320
	008127	WASTE CONNECTIONS OF 6741973W010	0	2023	3	INV A	475.16	C-122022	6010-1154340 @ 1551
	008127	WASTE CONNECTIONS OF 6741974W010	0	2023	3	INV A	472.58	C-122022	6010-1154341 @ 7411
							1,380.12		
	016517	UPCHURCH SERVICES, L 217002	0	2023	3	INV A	165.00	C-122022	BACK FLOW INSPECTIO
	016517	UPCHURCH SERVICES, L 217012	0	2023	3	INV A	123.00	C-122022	BACK FLOW INSPECTIO
	016517	UPCHURCH SERVICES, L 217013	0	2023	3	INV A	123.00	C-122022	BACK FLOW INSPECTIO
	016517	UPCHURCH SERVICES, L 217016	0	2023	3	INV A	123.00	C-122022	BACK FLOW INSPECTIO
	016517	UPCHURCH SERVICES, L 217017	0	2023	3	INV A	207.00	C-122022	BACK FLOW INSPECTIO
							741.00		
	033109	MID-SOUTH EMERGENCY 4845	0	2023	3	INV A	207.00	C-122022	COURT DEPT. - 30 SE
	033109	MID-SOUTH EMERGENCY 4847	0	2023	3	INV A	171.00	C-122022	ARENA - 30 SECOND E
							378.00		
	035717	NICHOLS FIRE 81266	0	2023	3	INV A	285.00	C-122022	SECURITY SERVICES F
							ACCOUNT TOTAL		
							3,369.12		
							ORG 160		
							TOTAL		
							9,135.93		
180									
180	610400								PLANNING / ENGINEERING DEPT
	004390	NOVATECH INC 2548610	0	2023	3	INV A	296.75	C-122022	OFFICE SUPPLIES
	004975	BAREFIELD WORKPLACE 1164049	0	2023	3	INV A	22.50	C-122022	CANON INK FOR PLOTT
	006685	DEX IMAGING AR8295638	0	2023	3	INV A	51.35	C-122022	23 CALENDARS & OFFI
	006685	DEX IMAGING AR8594601	0	2023	3	INV A	101.84	C-122022	#MP6615 - OFFICE SU
	006685	DEX IMAGING AR8595015	0	2023	3	INV A	53.99	C-122022	MP212272
							207.18		MP6615 CANON
	011136	DIAZIT COMPANY, INC 2229	0	2023	3	INV A	83.52	C-122022	
							ACCOUNT TOTAL		
							609.95		
180	611300								
	000021	A-1 FIRE PROTECTION 62448	0	2023	3	INV A	506.00	C-122022	MOTOR VEH REPAIRS/MAINT
							ACCOUNT TOTAL		
							506.00		FIRE EXTINGUISHERS
180	612500								
	020832	EMERGENCY EQUIPMENT 476851	0	2023	3	INV A	528.00	C-122022	UNIFORMS
							ACCOUNT TOTAL		
							528.00		UNIFORMS
180	622100								
							ACCOUNT TOTAL		
							PROFESSIONAL FEES		

12/15/2022 12:59
1540spri

CITY OF SOUTHAVEN
FY 2023 CLAIMS DOCKET C-122022

P 7
apinvgl

YEAR/PERIOD: 2023/1 TO 2023/3	ACCOUNT/VENDOR	INVOICE	PO	YEAR/PR	TYP	S	WARRANT	CHECK	DESCRIPTION
	000952 TYLER TECHNOLOGIES	25-380634	0	2023	3	INV A	8,982.00	C-122022	ENERGOV SOFTWARE IM
	000952 TYLER TECHNOLOGIES	45-397238	0	2023	3	INV A	1,480.00	C-122022	ENERGOV SOFTWARE IM
	000952 TYLER TECHNOLOGIES	45-401726	0	2023	3	INV A	5,180.00	C-122022	ENERGOV SOFTWARE IM
	000952 TYLER TECHNOLOGIES	45-402554	0	2023	3	INV A	2,960.00	C-122022	TYLER-ENERGOV TECHN
							18,602.00		
	018221 CIVIL-LINK, LLC	76523	0	2023	3	INV A	15,000.00	C-122022	MUNICIPAL STAFFING
						ACCOUNT TOTAL	33,602.00		
180	626900					TRAVEL & TRAINING			
	001449 GENTRY JAMES S	12-02-22	0	2023	3	INV A	59.00	C-122022	REIMBURSEMENT FOR F
						ACCOUNT TOTAL	59.00		
						ORG 180 TOTAL	35,304.95		
211						POLICE DEPARTMENT			
211	610100					CLEANING SUPPLIES			
	007823 AMERICAN PAPER & TWI	4502511	0	2023	3	INV A	130.50	C-122022	60 GAL TRASH
	007823 AMERICAN PAPER & TWI	4503882	0	2023	3	INV A	43.55	C-122022	HAND SOAP REFILL -
							174.05		
						ACCOUNT TOTAL	174.05		
211	610400					OFFICE SUPPLIES			
	004975 BAREFIELD WORKPLACE	1164049	0	2023	3	INV A	97.50	C-122022	23 CALENDARS & OFFI
	007600 ODP BUSINESS	277359498001	0	2023	3	INV A	261.27	C-122022	FLASH DRIVES
	007600 ODP BUSINESS	277367305001	0	2023	3	INV A	79.90	C-122022	FLASH DRIVE
	007600 ODP BUSINESS	277910173001	0	2023	3	INV A	152.47	C-122022	OFFICE SUPPLIES
	007600 ODP BUSINESS	277910173002	0	2023	3	INV A	7.19	C-122022	OFFICE SUPPLIES
							500.83		
	030629 AMAZON CAPITAL	11FHHNDPT1P9	0	2023	3	INV A	38.99	C-122022	#ANKP067K88KPB-SRO
	030629 AMAZON CAPITAL	1LYXVK9V4TPT	0	2023	3	INV A	99.91	C-122022	#ANKP067K88KPB-24IB
							138.90		
						ACCOUNT TOTAL	737.23		
211	611000					MATERIALS			
	000544 PRECISION DELTA CORP	25576	23000079	2023	3	INV A	1,974.80	C-122022	2023FY PARTIAL SPD
	012445 ACCURATE LAW ENFOR	20-2513	0	2023	3	INV A	496.00	C-122022	2 HOLOSUN
						ACCOUNT TOTAL	2,470.80		
211	611300					MAINTENANCE VEHICLES			

12/15/2022 12:59
1540spri

CITY OF SOUTHAVEN
FY 2023 CLAIMS DOCKET C-122022

P 8
apinvgl

YEAR/PERIOD: 2023/1 TO 2023/3	ACCOUNT/VENDOR	INVOICE	PO	YEAR/PR	TYP	S	WARRANT	CHECK	DESCRIPTION
	000543 COMSERV SERVICES	732005070	0	2023	3	INV A	1,129.00	C-122022	3230 INSTALL
	000883 AMERICAN TIRE REPAIR	162515	0	2023	3	INV A	2,108.32	C-122022	16 TIRES
	007304 O'REILLYS AUTO PARTS	6399-124700	0	2023	3	INV A	312.85	C-122022	SHOP PARTS
	007600 ODP BUSINESS	277917463001	0	2023	3	INV A	1,176.39	C-122022	STOCK KEY FOB BATTE
	018451 DESOTO COLLISION	19248	23000030	2023	3	INV A	7,098.92	C-122022	BODY REPAIR WORK FO
	019700 CHOICE TOWING	75098	0	2023	3	INV A	65.00	C-122022	3106 TOW
	019700 CHOICE TOWING	75146	0	2023	3	INV A	50.00	C-122022	3165 TOW
							115.00		
							ACCOUNT TOTAL		11,940.48
211	612200						MAINTENANCE EQUIPMENT & BUILD		
	001102 SOUTHAVEN SUPPLY	164689	0	2023	3	INV A	5.58	C-122022	KEY
	019694 MID-SOUTH TELECOM	75267	0	2023	3	INV A	1,298.00	C-122022	2 TV'S
							ACCOUNT TOTAL		1,303.58
211	612500						UNIFORMS		
	021916 MIDSOUTH SOLUTIONS	192604	0	2023	3	INV A	626.00	C-122022	BRENT VICKERS - ALL
	021916 MIDSOUTH SOLUTIONS	192877	23000044	2023	3	INV A	65.99	C-122022	BRANNING, MICHEAL U
	021916 MIDSOUTH SOLUTIONS	192924	23000044	2023	3	INV A	263.99	C-122022	BRANNING, MICHEAL U
	021916 MIDSOUTH SOLUTIONS	192927	23000048	2023	3	INV A	533.00	C-122022	LONG, THOMAS UNIFOR
	021916 MIDSOUTH SOLUTIONS	193169	23000117	2023	3	INV A	496.45	C-122022	MARTIN ROBY ALLOT.
							1,985.43		
	034787 RUSSELL KALEY	11-28-2022	0	2023	3	INV A	600.00	C-122022	ALLOTMENT
							ACCOUNT TOTAL		2,585.43
211	614000						FUEL & OIL		
	006919 FUELMAN	NP63307011	0	2023	3	INV A	10,143.94	C-122022	FUEL FOR FLEET
	006919 FUELMAN	NP63330218	0	2023	3	INV A	8,611.84	C-122022	FUEL FOR FLEET
							18,755.78		
							ACCOUNT TOTAL		18,755.78
211	614900						FEED FOR ANIMALS		
	010919 TRACTOR SUPPLY CREDI	300251371	0	2023	3	CRM A	-47.64	C-122022	CREDIT - RETURN 1 W
	019336 HOLLYWOOD FEED	111522	0	2023	3	INV A	42.25	C-122022	K-9 FOOD
	030629 AMAZON CAPITAL	1Q3X4FD31DPK	0	2023	3	INV A	399.99	C-122022	K9 BALL TRAINER

12/15/2022 12:59
1540spri

CITY OF SOUTHAVEN
FY 2023 CLAIMS DOCKET C-122022

P 9
apinvgl

YEAR/PERIOD: 2023/1	TO 2023/3	ACCOUNT/VENDOR	INVOICE	PO	YEAR/PR	TYP	S	WARRANT	CHECK	DESCRIPTION
ACCOUNT TOTAL								394.60		
211	622100				PROFESSIONAL SERVICES					
	000597	SIRCHIE ACQUISITION	570965	0	2023	3	INV A	191.38	C-122022	GUN BOXES
	001390	DPS CRIME LAB	90125843	0	2023	3	INV A	360.00	C-122022	ANALYTICAL FEES
	006685	DEX IMAGING	AR8547061	0	2023	3	INV A	140.58	C-122022	LT HALL
	022516	PERSONNEL EVALUATION	46282	0	2023	3	INV A	350.00	C-122022	EVALS
	029355	GRAYSHIFT LLC	INV01907	23000112	2023	3	INV A	16,490.00	C-122022	CELL PHONE EXTRACTI
	033109	MID-SOUTH EMERGENCY	4889	0	2023	3	INV A	180.00	C-122022	EMERGENCY LIGHTING
	034860	FORENSIC POLYGRAPH S	150	0	2023	3	INV A	400.00	C-122022	2 POLYS
	034860	FORENSIC POLYGRAPH S	151	0	2023	3	INV A	400.00	C-122022	2 POLYS
								800.00		
	036757	MOBILE DRUG TESTING	10262022	0	2023	3	INV A	827.09	C-122022	LAB TESTING
ACCOUNT TOTAL								19,339.05		
211	626102				PUBLIC RELATIONS					
	000424	A 2 Z ADVERTISING	64270	0	2023	3	INV A	739.00	C-122022	K9 SHIRTS
ACCOUNT TOTAL								739.00		
211	626900				TRAVEL & TRAINING					
	012445	ACCURATE LAW ENFOR	20-2399	0	2023	3	INV A	659.52	C-122022	TRAINING GUM
	026086	TACTICAL OFFICER SUR	12-8-2022	0	2023	3	INV A	900.00	C-122022	FIREARMS INSTRUCTOR
	027770	GLOBAL POLICE SOLUTI	12-09-22	0	2023	3	INV A	569.00	C-122022	DECTIVE LEVEL 1 TRA
ACCOUNT TOTAL								2,128.52		
211	630400				MACHINERY & EQUIPMENT					
	012445	ACCURATE LAW ENFOR	20-2531	0	2023	3	INV A	1,124.30	C-122022	10 WEAPON LIGHTS
	025553	AXON ENTERPRISE INC	INUSS115704	23000108	2023	3	INV A	8,749.99	C-122022	RENEWAL OF 15 BODY
	031452	REKOR RECOGNITION SY	INV-0002768	23000119	2023	3	INV A	13,860.00	C-122022	LPR YEARLY SERVICE
	032121	GUN SHOP LLC	11292022	0	2023	3	INV A	380.00	C-122022	MAGPUL RAILS
	032121	GUN SHOP LLC	12052022	0	2023	3	INV A	196.00	C-122022	SLING SWIVEL & MOUN
								576.00		
	036205	PROLOGIC ITS, LLC	INV04543	0	2023	3	INV A	219.79	C-122022	HEADREST TEST

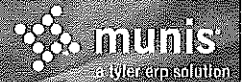

12/15/2022 12:59
1540spri

CITY OF SOUTHAVEN
FY 2023 CLAIMS DOCKET C-122022

P 10
apinvgl

YEAR/PERIOD: 2023/1 TO 2023/3								
ACCOUNT/VENDOR	INVOICE	PO	YEAR/PR	TYP	S	WARRANT	CHECK	DESCRIPTION
					ACCOUNT TOTAL	24,530.08		
211	661800		CONFISCATED FUNDS-LOCAL					
006706	LANDERS DODGE	234854	23000123	2023	3 INV A	31,500.00	C-122022	DODGE CHARGER FOR T
					ACCOUNT TOTAL	31,500.00		
					ORG 211 TOTAL	116,598.60		
EMERGENCY SERVICES								
215	610400		OFFICE SUPPLIES					
004975	BAREFIELD WORKPLACE	1164049	0	2023	3 INV A	6.00	C-122022	23 CALENDARS & OFFI
					ACCOUNT TOTAL	6.00		
UNIFORMS								
215	612500		UNIFORMS					
000424	A 2 Z ADVERTISING	64222	0	2023	3 INV A	28.00	C-122022	A FLEMING UNIFORM
000424	A 2 Z ADVERTISING	64223	0	2023	3 INV A	86.94	C-122022	A VANCE UNIFORMS
						114.94		
					ACCOUNT TOTAL	114.94		
PROFESSIONAL FEES								
215	622100		PROFESSIONAL FEES					
002564	LANGUAGE LINE SERVIC	10687323	0	2023	3 INV A	243.11	C-122022	LANGUAGE LINE
					ACCOUNT TOTAL	243.11		
TRAVEL & TRAINING								
215	626900		TRAVEL & TRAINING					
008309	INTERNATIONAL ACADEM	SIN324399	0	2023	3 INV A	1,460.00	C-122022	EMD CLASS
008309	INTERNATIONAL ACADEM	SIN324401	0	2023	3 INV A	500.00	C-122022	EMD CLASS FEE
						1,960.00		
					ACCOUNT TOTAL	1,960.00		
					ORG 215 TOTAL	2,324.05		
FIRE DEPARTMENT								
290	610400		OFFICE SUPPLIES					
004975	BAREFIELD WORKPLACE	1164049	0	2023	3 INV A	22.50	C-122022	23 CALENDARS & OFFI
007823	AMERICAN PAPER & TWI	4500962	0	2023	3 INV A	227.20	C-122022	COPY PAPER & JANITO
					ACCOUNT TOTAL	249.70		
COMPUTER LICENSE								
290	610600		COMPUTER LICENSE					
001416	NFPA	8332170X	0	2023	3 INV A	175.00	C-122022	MEMBERSHIP FEES
001416	NFPA	8332171X	0	2023	3 INV A	1,552.50	C-122022	NATIONAL FIRE CODES
						1,727.50		

12/15/2022 12:59
1540spri

CITY OF SOUTHAVEN
FY 2023 CLAIMS DOCKET C-122022

P 11
apinvgl

YEAR/PERIOD: 2023/1 TO 2023/3									
ACCOUNT/VENDOR	INVOICE	PO	YEAR/PR	TYP	S	WARRANT	CHECK	DESCRIPTION	
ACCOUNT TOTAL						1,727.50			
290	611000								
007304	O'REILLYS AUTO PARTS 1791-204389	0	2023	3	INV A	23.00	C-122022	TAPE/CAR CHARGER EN	
015230	MY-LOR. INC. 4508	0	2023	3	INV A	25.40	C-122022	2 NEW HIRE ID TAGS	
020832	EMERGENCY EQUIPMENT 477047	0	2023	3	INV A	72.80	C-122022	KOCHEK UNIVERSAL SP	
020832	EMERGENCY EQUIPMENT 477056	0	2023	3	INV A	10.00	C-122022	STREAMLIGHT FACE CA	
020832	EMERGENCY EQUIPMENT 477127	0	2023	3	INV A	110.00	C-122022	NST MOUNTING PLATE	
ACCOUNT TOTAL						192.80			
ACCOUNT TOTAL						241.20			
290	611300								
000189	HOMER SKELTON FORD 6156255	0	2023	3	INV A	232.50	C-122022	OIL/FILTER CHANGES	
000883	AMERICAN TIRE REPAIR 161844	0	2023	3	INV A	537.55	C-122022	1 NEW TIRE/MOUNT-DI	
000883	AMERICAN TIRE REPAIR 162065	0	2023	3	INV A	30.00	C-122022	FLAT TIRE REPAIR F1	
000883	AMERICAN TIRE REPAIR 162250	0	2023	3	INV A	537.55	C-122022	1 NEW TIRE/MOUNT DI	
000883	AMERICAN TIRE REPAIR 162537	0	2023	3	INV A	2,461.52	C-122022	4 NEW TIRES/MOUNT S	
ACCOUNT TOTAL						3,566.62			
006706	LANDERS DODGE 339258	0	2023	3	INV A	292.23	C-122022	REPLACED BATTERY DO	
007304	O'REILLYS AUTO PARTS 1791-204228	0	2023	3	INV A	41.99	C-122022	BATT TENDER	
007304	O'REILLYS AUTO PARTS 1791-204672	0	2023	3	INV A	47.98	C-122022	2 GAL TRANS FLD ENG	
ACCOUNT TOTAL						89.97			
ACCOUNT TOTAL						4,181.32			
290	612200								
020832	EMERGENCY EQUIPMENT 476879	0	2023	3	INV A	52.90	C-122022	LOWER STRAPS SCOTT	
030049	AVON PROTECTION SYS 168892	0	2023	3	INV A	704.00	C-122022	REPAIRS TO THERMAL	
ACCOUNT TOTAL						756.90			
290	612500								
021916	MIDSOUTH SOLUTIONS 4944	0	2023	3	INV A	196.90	C-122022	UNIFORMS (LT.) FOR	
ACCOUNT TOTAL						196.90			
290	614000								
006919	FUELMAN NP63273824	0	2023	3	INV A	57.52	C-122022	#BG127181 - FUEL FO	
006919	FUELMAN NP63307026	0	2023	3	INV A	33.74	C-122022	FUEL	
006919	FUELMAN NP63409703	0	2023	3	INV A	157.58	C-122022	#BG127181 - FUEL FO	
ACCOUNT TOTAL						248.84			

12/15/2022 12:59
 1540spri

 CITY OF SOUTHAVEN
 FY 2023 CLAIMS DOCKET C-122022

 P 12
 apinvgl

YEAR/PERIOD: 2023/1	TO 2023/3								
ACCOUNT/VENDOR	INVOICE	PO	YEAR/PR	TYP	S	WARRANT	CHECK	DESCRIPTION	
ACCOUNT TOTAL						248.84			
290	626500								
029120	YOUNG LEASING CO	INV4868942	0	2023	3 INV A	244.70	C-122022	#AAA47533-COPIER FE	
ACCOUNT TOTAL						244.70			
290	626900								
001102	SOUTHAVEN SUPPLY	164691	0	2023	3 INV A	6.58	C-122022	MATERIALS FOR TRAIN	
001147	NEXAIR LLC	10472344	0	2023	3 INV A	141.39	C-122022	RENTAL FEES FOR NIT	
013215	HODGES JEREMY	11-22-2022	0	2023	3 INV A	145.00	C-122022	PER DIEM: ENGINE CO	
013215	HODGES JEREMY	11-22-22	0	2023	3 INV A	87.00	C-122022	PER DIEM: MSFA TCCC	
						232.00			
020055	FORESMAN EVAN	12-13-2022	0	2023	3 INV A	145.00	C-122022	STATE FIRE ACADEMY (
030947	GRIFFITH HUNTER	12-9-2022	0	2023	3 INV A	290.00	C-122022	DRIVER/OPERATOR NFP	
034584	TOMLINSON LOUIS M	11-22-22	0	2023	3 INV A	145.00	C-122022	ENGINE COMPANY OPER	
ACCOUNT TOTAL						959.97			
290	630400								
029766	EDI LLC	1206	0	2023	3 INV A	1,527.00	C-122022	PLYMOVENT REPAIRS F	
ACCOUNT TOTAL						1,527.00			
290	630600								
000543	COMSERV SERVICES	732005009	0	2023	3 INV A	12,631.95	C-122022	INSTALLATION ACTIVA	
ACCOUNT TOTAL						12,631.95			
ORG 290 TOTAL						22,965.98			
295									
FIRE PREVENTION									
295	626102								
031457	BKBQ II LLC	W5986	0	2023	3 INV A	1,571.47	C-122022	AWARDS BANQUET	
ACCOUNT TOTAL						1,571.47			
ORG 295 TOTAL						1,571.47			
297									
EMS									
297	610701								
000567	DESOTO COUNTY BOARD	110122	0	2023	3 INV A	350.07	C-122022	MEDICAL SUPPLIES	
000567	DESOTO COUNTY BOARD	112822	0	2023	3 INV A	466.76	C-122022	MEDICAL SUPPLIES	
						816.83			

12/15/2022 12:59
1540apri

CITY OF SOUTHAVEN
FY 2023 CLAIMS DOCKET C-122022

P 13
apinvgla

YEAR/PERIOD: 2023/1 TO 2023/3									
ACCOUNT/VENDOR	INVOICE	PO	YEAR/PR	TYP	S	WARRANT	CHECK	DESCRIPTION	
000582 BOUND TREE MEDICAL	84771474	0	2023 3	INV	A	453.77	C-122022	MEDICAL SUPPLIES	
000582 BOUND TREE MEDICAL	84779275	0	2023 3	INV	A	1,058.60	C-122022	MEDICAL SUPPLIES	
000582 BOUND TREE MEDICAL	84788894	0	2023 3	INV	A	234.79	C-122022	MEDICAL SUPPLIES	
						1,747.16			
001147 NEXAIR LLC	10434838	0	2023 3	INV	A	129.44	C-122022	MEDICAL SUPPLIES OX	
001147 NEXAIR LLC	10440123	0	2023 3	INV	A	105.19	C-122022	MEDICAL SUPPLIES OX	
001147 NEXAIR LLC	10469200	0	2023 3	INV	A	412.28	C-122022	RENTAL FEES FOR NOV	
001147 NEXAIR LLC	10497443	0	2023 3	INV	A	120.83	C-122022	#L0490-MEDICAL SUPP	
						767.74			
015430 ZOLL MEDICAL CORPORA	3614125	0	2023 3	INV	A	808.50	C-122022	MEDICAL SUPPLIES	
015430 ZOLL MEDICAL CORPORA	3615311	0	2023 3	INV	A	266.50	C-122022	MEDICAL SUPPLIES	
015430 ZOLL MEDICAL CORPORA	3621911	0	2023 3	INV	A	1,130.20	C-122022	MEDICAL SUPPLIES	
						2,205.20			
016050 HENRY SCHEIN INC	29534210	0	2023 3	INV	A	1,664.08	C-122022	MEDICAL SUPPLIES	
016050 HENRY SCHEIN INC	29971884	0	2023 3	INV	A	1,831.43	C-122022	MEDICAL SUPPLIES	
016050 HENRY SCHEIN INC	30073245	0	2023 3	INV	A	34.96	C-122022	MEDICAL SUPPLIES	
						3,530.47			
027573 TELEFLEX MEDICAL INC	9506306472	0	2023 3	INV	A	562.50	C-122022	MEDICAL SUPPLIES	
ACCOUNT TOTAL						9,629.90			
297 611300			MOTOR VEH REPAIRS/MAINT						
000189 HOMER SKELTON FORD	6156140	0	2023 3	INV	A	115.43	C-122022	OIL/FILTER CHANGE U	
000189 HOMER SKELTON FORD	6156454	0	2023 3	CRM	A	-15.21	C-122022	CREDIT- TAXES THAT	
						100.22			
ACCOUNT TOTAL						100.22			
297 620901			BILLING SERVICES						
018772 MEDICAL ACCOUNTS REC	109039	0	2023 3	INV	A	11,991.02	C-122022	MEDICAL BILLING FOR	
ACCOUNT TOTAL						11,991.02			
297 622100			PROFESSIONAL FEES						
012561 EMERGENCY MEDICAL RE	202220	0	2023 3	INV	A	4,500.00	C-122022	4TH QUARTER MEDICAL	
ACCOUNT TOTAL						4,500.00			
297 626900			TRAVEL & TRAINING						
001412 BARNETT RICKEY	113022	0	2023 3	INV	A	73.90	C-122022	RENEWAL OF NRSMT &M	
007888 WOODARD CRAIG	113022	0	2023 3	INV	A	72.00	C-122022	RENEWAL OF NREMT/MS	

12/15/2022 12:59
1540spri

CITY OF SOUTHAVEN
FY 2023 CLAIMS DOCKET C-122022

P 14
apinvgl

YEAR/PERIOD: 2023/1 TO 2023/3	ACCOUNT/VENDOR	INVOICE	PO	YEAR/PR	TYP	S	WARRANT	CHECK	DESCRIPTION
	008335 WEBB RONALD	112322	0	2023	3	INV A	66.90	C-122022	RENEWAL NREMT & STA
	016964 HITT MATT	12722	0	2023	3	INV A	72.00	C-122022	RENEWAL OF NREMT-D
	017309 MCDANIEL PAUL	113022	0	2023	3	INV A	73.90	C-122022	RENEWAL NREMT MS ST
	026195 JOHNSON MICHAEL	12522	0	2023	3	INV A	65.00	C-122022	RENEWAL NREMT /MS S
	027868 CAMPBELL JORDAN	12722	0	2023	3	INV A	55.00	C-122022	RENEWAL OF EMS-D LI
	033400 CALI STEPHEN A	111722	0	2023	3	INV A	32.00	C-122022	RENEWAL OF NREMT ME
	033400 CALI STEPHEN A	112422	0	2023	3	INV A	40.00	C-122022	RENEWAL OF MS STATE
							72.00		
	036825 BECERRA ERIC	12522	0	2023	3	INV A	40.00	C-122022	EMS DRIVERS LICENSE
						ACCOUNT TOTAL	590.70		
						ORG 297 TOTAL	26,811.84		
311						PUBLIC WORKS DEPARTMENT			
311	610400					OFFICE SUPPLIES			
	004975 BAREFIELD WORKPLACE	1164049	0	2023	3	INV A	7.50	C-122022	23 CALENDARS & OFFI
	007600 ODP BUSINESS	278478674001	0	2023	3	INV A	29.96	C-122022	GEL INK PENS
						ACCOUNT TOTAL	37.46		
311	611000					MATERIALS			
	000354 METER SERVICE AND SU	28906	0	2023	3	INV A	825.00	C-122022	88' #6-72 CURB PLAT
	000759 LEHMAN ROBERTS CO	89048	0	2023	3	INV A	355.51	C-122022	MATERIAL: PLANT #5
	000759 LEHMAN ROBERTS CO	89078	0	2023	3	INV A	752.63	C-122022	MATERIAL: PLANT #5
							1,108.14		
	001102 SOUTHAVEN SUPPLY	163831	0	2023	3	INV A	361.51	C-122022	MAT. FOR SHOP/WIRE
	001130 G & C SUPPLY CO	6887216	0	2023	3	INV A	2,991.10	C-122022	STREET SIGNS
	001320 MARTIN MACHINE WORKS	1616	0	2023	3	INV A	986.00	C-122022	MAT. - PINS FOR VAR
	007304 O'REILLYS AUTO PARTS	6399-134328	0	2023	3	INV A	166.71	C-122022	MAT FOR SHOP
	017201 BEST-WADE PETROLEUM	1067968	0	2023	3	INV A	959.29	C-122022	55 GAL DRUMS
						ACCOUNT TOTAL	7,397.75		
311	611300					MAINTENANCE VEHICLES			
	000883 AMERICAN TIRE REPAIR	160830	0	2023	3	INV A	251.64	C-122022	MAT FOR SHOP

12/15/2022 12:59
1540apri

CITY OF SOUTHAVEN
FY 2023 CLAIMS DOCKET C-122022

YEAR/PERIOD: 2023/1 TO 2023/3
ACCOUNT/VENDOR INVOICE

ACCOUNT/VENDOR	INVOICE	PO	YEAR/PR	TYP	S	WARRANT	CHECK	DESCRIPTION
000883 AMERICAN TIRE REPAIR	161845	0	2023 3	INV	A	784.40	C-122022	MAT FOR SHOP
						1,036.04		
000949 INTEGRATED COMMUNICA	32489	0	2023 3	INV	A	1,860.00	C-122022	MAT. FOR SHOP - BIL
001150 NAPA GENUINE PARTS C	846849	0	2023 3	INV	A	37.92	C-122022	MAT FOR SHOP
004246 HARBOR FREIGHT TOOLS	998304	0	2023 3	INV	A	220.33	C-122022	MAT. FOR SHOP - 9PC
004246 HARBOR FREIGHT TOOLS	998305	0	2023 3	INV	A	42.79	C-122022	MAT. FOR SHOP - 450
						263.12		
006479 AIRGAS USA INC	9132254563	0	2023 3	INV	A	128.50	C-122022	MAT. FOR SHOP
006479 AIRGAS USA INC	9993345852	0	2023 3	INV	A	59.05	C-122022	MAT. FOR SHOP - REN
						187.55		
007304 O'REILLYS AUTO PARTS	1257-199274	0	2023 3	INV	A	179.90	C-122022	BLUEDEF 2.5 - MAT.
007304 O'REILLYS AUTO PARTS	1257-205949	0	2023 3	INV	A	6.99	C-122022	STAR SOCKET - MAT.
007304 O'REILLYS AUTO PARTS	1257-208585	0	2023 3	INV	A	24.99	C-122022	MAT FOR SHOP
007304 O'REILLYS AUTO PARTS	1791-200987	0	2023 3	INV	A	11.99	C-122022	QT BRAKE FLUID - MA
007304 O'REILLYS AUTO PARTS	1791-204844	0	2023 3	INV	A	56.98	C-122022	NITRILE GLV - MAT.
007304 O'REILLYS AUTO PARTS	6399-123785	0	2023 3	INV	A	232.98	C-122022	MAT. FOR SHOP - BAT
007304 O'REILLYS AUTO PARTS	6399-126076	0	2023 3	INV	A	311.46	C-122022	2-BATTERY, 2-CORE C
007304 O'REILLYS AUTO PARTS	6399-126194	0	2023 3	INV	A	73.53	C-122022	MAT. FOR SHOP - TRA
007304 O'REILLYS AUTO PARTS	6399-128692	0	2023 3	INV	A	39.98	C-122022	MAT. FOR SHOP/320 O
007304 O'REILLYS AUTO PARTS	6399-129435	0	2023 3	INV	A	110.31	C-122022	MAT. FOR SHOP - IGN
007304 O'REILLYS AUTO PARTS	6399-130013	0	2023 3	INV	A	54.93	C-122022	MAT. FOR SHOP/SEMI-
007304 O'REILLYS AUTO PARTS	6399-130033	0	2023 3	INV	A	132.33	C-122022	MAT. FOR SHOP - BAT
007304 O'REILLYS AUTO PARTS	6399-130132	0	2023 3	INV	A	18.99	C-122022	MAT. FOR SHOP - FUS
007304 O'REILLYS AUTO PARTS	6399-130451	0	2023 3	INV	A	43.18	C-122022	MAT. FOR SHOP/REPAI
007304 O'REILLYS AUTO PARTS	6399-130686	0	2023 3	INV	A	75.73	C-122022	MAT. FOR SHOP - TER
007304 O'REILLYS AUTO PARTS	6399-131441	0	2023 3	INV	A	342.51	C-122022	1 QT MOTOR OIL - MA
007304 O'REILLYS AUTO PARTS	6399-134222	0	2023 3	INV	A	22.99	C-122022	MAT FOR SHOP
007304 O'REILLYS AUTO PARTS	6399-134242	0	2023 3	INV	A	194.89	C-122022	MAT FOR SHOP
007304 O'REILLYS AUTO PARTS	6399-134782	0	2023 3	INV	A	20.47	C-122022	MAT FOR SHOP
007304 O'REILLYS AUTO PARTS	6399-134792	0	2023 3	INV	A	180.95	C-122022	MAT FOR SHOP
007304 O'REILLYS AUTO PARTS	6399-135094	0	2023 3	INV	A	274.67	C-122022	MAT FOR SHOP
007304 O'REILLYS AUTO PARTS	6399-135129	0	2023 3	INV	A	125.00	C-122022	MAT FOR SHOP
007304 O'REILLYS AUTO PARTS	6399-135471	0	2023 3	INV	A	107.54	C-122022	MAT FOR SHOP
007304 O'REILLYS AUTO PARTS	6399-135502	0	2023 3	INV	A	236.66	C-122022	MAT FOR SHOP
007304 O'REILLYS AUTO PARTS	6399-135568	0	2023 3	INV	A	484.78	C-122022	MAT FOR SHOP [
007304 O'REILLYS AUTO PARTS	6399-135573	0	2023 3	INV	A	347.94	C-122022	MAT FOR SHOP
007304 O'REILLYS AUTO PARTS	6399-135605	0	2023 3	INV	A	37.98	C-122022	MAT FOR SHOP
						3,750.65		
013491 GATEWAY TIRE	1023-154500	0	2023 3	INV	A	91.75	C-122022	MAT FOR SHOP
013491 GATEWAY TIRE	1023-154557	0	2023 3	INV	A	153.39	C-122022	MAT FOR SHOP
						245.14		

12/15/2022 12:59
1540spr1

CITY OF SOUTHAVEN
FY 2023 CLAIMS DOCKET C-122022

P 16
apinvgl

YEAR/PERIOD: 2023/1 ACCOUNT/VENDOR	TO 2023/3 INVOICE	PO	YEAR/PR	TYP	S	WARRANT	CHECK	DESCRIPTION
021908 STRYKER	3967398M	0	2023 3	INV	A	4,167.98	C-122022	MAT. FOR SHOP/STRAP
024154 DISCOUNT TIRE	1326817	0	2023 3	INV	A	1,408.00	C-122022	MAT. FOR SHOP
024154 DISCOUNT TIRE	1329864	0	2023 3	INV	A	1,464.00	C-122022	MAT. FOR SHOP
						2,872.00		
034150 LAWSON PRODUCTS, INC	9310128453	0	2023 3	INV	A	39.18	C-122022	MAT FOR SHOP
035031 COLD MIX INC	17915	0	2023 3	INV	A	4,084.08	C-122022	COLD MIX - DELIVERY
						ACCOUNT TOTAL	18,543.66	
311 612200								MAINTENANCE EQUIPMENT & BUILD
014714 INTEGRATED WIRELES	23787	0	2023 3	INV	A	556.40	C-122022	MATERIALS /EQUIP
						ACCOUNT TOTAL	556.40	
311 612500								UNIFORMS
013377 CINTAS	4137661182	0	2023 3	INV	A	434.42	C-122022	UNIFORMS
						ACCOUNT TOTAL	434.42	
311 622100								PROFESSIONAL SERVICES
005095 WOODS TREE SERVICE	91822	0	2023 3	INV	A	4,525.00	C-122022	TREE REMOVAL SERVIC
						ACCOUNT TOTAL	4,525.00	
311 630400								MACHINERY & EQUIPMENT
015391 MID-SOUTH AG EQUIPME	E18794	23000101	2023 3	INV	A	108,375.23	C-122022	2022 NEW CASE IH125
029563 LANDERS FORD SOUTH	249435	0	2023 3	INV	A	43,227.00	C-122022	PUBLIC WORKS - 1696
029563 LANDERS FORD SOUTH	249517	0	2023 3	INV	A	43,227.00	C-122022	PUBLIC WORKS 16962
						86,454.00		
						ACCOUNT TOTAL	194,829.23	
						ORG 311 TOTAL	226,323.92	
315								CITY TRAFFIC AND STREETS LIGHT
315 612200								MAINTENANCE EQUIPMENT & BUILD
000497 DESOTO COUNTY ELECT'R	7816	0	2023 3	INV	A	4,120.31	C-122022	SIGNAL REPAIR
						ACCOUNT TOTAL	4,120.31	
						ORG 315 TOTAL	4,120.31	
411								PARKS DEPARTMENT
411 610400								OFFICE SUPPLIES
004975 BAREFIELD WORKPLACE	1164049	0	2023 3	INV	A	22.50	C-122022	23 CALENDARS & OFFI

12/15/2022 12:59
1540spri

CITY OF SOUTHAVEN
FY 2023 CLAIMS DOCKET C-122022

P 17
apinvgl

YEAR/PERIOD: 2023/1 TO 2023/3									
ACCOUNT/VENDOR	INVOICE	PO	YEAR/PR	TYP	S	WARRANT	CHECK	DESCRIPTION	
006685 DEX IMAGING	AR8617768	0	2023 3	INV	A	19.90	C-122022	#MP8956 - COPY CONT	
006685 DEX IMAGING	AR8617769	0	2023 3	INV	A	5.22	C-122022	#A2615 - COPY CONTR	
						25.12			
029120 YOUNG LEASING CO	INV6037508	0	2023 3	INV	A	190.18	C-122022	#AAA50825 - COPY CO	
ACCOUNT TOTAL						237.80			
411 612200			MAINTENANCE EQUIPMENT & BUILD						
000239 QUALITY LANDSCAPE &	22545	0	2023 3	INV	A	96.00	C-122022	12 HAY BALE WHEAT	
000308 MAINTENANCE SUPPLY	236303	0	2023 3	INV	A	273.00	C-122022	SCREW, DRILL BIT, C	
000308 MAINTENANCE SUPPLY	236395	0	2023 3	INV	A	234.40	C-122022	ZIP TIES	
						507.40			
001150 NAPA GENUINE PARTS C	38618	0	2023 3	INV	A	184.29	C-122022	BATTERY	
001150 NAPA GENUINE PARTS C	387166	0	2023 3	INV	A	12.98	C-122022	TIRE REPAIR KIT	
001150 NAPA GENUINE PARTS C	695-386196	0	2023 3	INV	A	167.76	C-122022	OIL FILTERS	
						365.03			
011134 WHITFIELD	85489	0	2023 3	INV	A	1,760.00	C-122022	BP SPORTS CENTER-RE	
013377 CINTAS	4138797931	0	2023 3	INV	A	120.55	C-122022	SCRAPER, BLACK MAT	
013377 CINTAS	4138798329	0	2023 3	INV	A	85.19	C-122022	AIR FRESHENER REFIL	
013377 CINTAS	4139025644	0	2023 3	INV	A	70.45	C-122022	ONYX, SCRAPER MAT &	
013377 CINTAS	4139543920	0	2023 3	INV	A	120.55	C-122022	ACTIVE SCRAPER, HB	
013377 CINTAS	4139544300	0	2023 3	INV	A	85.19	C-122022	AIR FRESHENER, MAT.	
013377 CINTAS	4139702951	0	2023 3	INV	A	70.45	C-122022	SCRAPER MAT. & BLAC	
013377 CINTAS	4140249243	0	2023 3	INV	A	134.36	C-122022	SCRAPER & MATS	
013377 CINTAS	4140249592	0	2023 3	INV	A	85.19	C-122022	AIR FRESHENER & MAT	
						771.93			
020449 FINAL TOUCH SECURITY	75185	0	2023 3	INV	A	140.00	C-122022	SERVICE CALL @ GREE	
032978 MR GEE'S CARPET CLEA	6667	0	2023 3	INV	A	2,571.80	C-122022	STRIP & WAX FLOORS	
033109 MID-SOUTH EMERGENCY	4886	0	2023 3	INV	A	54.00	C-122022	INSPECTION ON EM LI	
033109 MID-SOUTH EMERGENCY	4887	0	2023 3	INV	A	18.00	C-122022	INSPECTION ON EM LI	
033109 MID-SOUTH EMERGENCY	4888	0	2023 3	INV	A	909.00	C-122022	QUARTERLY INSPECTIO	
						981.00			
ACCOUNT TOTAL						7,193.16			
411 612201			PARK MAINTENANCE						
000239 QUALITY LANDSCAPE &	22522	0	2023 3	INV	A	160.00	C-122022	WHEAT STRAW	

12/15/2022 12:59
1540spri

CITY OF SOUTHAVEN
FY 2023 CLAIMS DOCKET C-122022

P 18
apinvgl

YEAR/PERIOD: 2023/1 ACCOUNT/VENDOR	TO 2023/3 INVOICE	PO	YEAR/PR TYP S	WARRANT	CHECK	DESCRIPTION
001056 BWI MEMPHIS	17406770	0	2023 3 INV A	878.00 C-122022		LIQUID HERBICIDE
007823 AMERICAN PAPER & TWI	4506837	0	2023 3 INV A	286.59 C-122022		JANITORIAL SUPPLIES
009591 TRI FIRMA	6462	0	2023 3 INV A	6,368.33 C-122022		TERM BID REPAIR TO
011134 WHITFIELD	85493	0	2023 3 INV A	399.92 C-122022		REPLACED LIGHT - FO
011969 PIONEER MANUFACTURIN	INV865718	0	2023 3 INV A	4,348.62 C-122022		FIELD PAINT
025799 PROPUMP AND CONTROLS	51858-IN	0	2023 3 INV A	795.00 C-122022		WINTERIZATION ON PU
026449 KELLY SEPTIC SER	21059	0	2023 3 INV A	190.00 C-122022		PORTA POTTY SERVICE
026449 KELLY SEPTIC SER	22646	0	2023 3 INV A	275.00 C-122022		PORTA POTTY SERVICE
026449 KELLY SEPTIC SER	23223	0	2023 3 INV A	300.00 C-122022		PORTA POTTY SERVICE
				765.00		
028607 WINSTEAD TURF FARMS	38051-TL	0	2023 3 INV A	400.00 C-122022		PALLETS
036758 SHAMBAUGH & SON	18264321	0	2023 3 INV A	8.25 C-122022		BACKFLOW TEST ANNUA
			ACCOUNT TOTAL	14,409.71		
411 612500			UNIFORMS			
003011 M & M PROMOTIONS	97438	0	2023 3 INV A	164.95 C-122022		UNIFORM PANTS
			ACCOUNT TOTAL	164.95		
411 613400			COMMUNITY EVENTS			
000378 WAYNES CANDY CO INC	101742	0	2023 3 INV A	1,378.57 C-122022		CANDY FOR PARADE FL
030074 REINDERS	2048534	0	2023 3 INV A	96.67 C-122022		SOUTHERN LIGHTS BUL
030074 REINDERS	2049556	0	2023 3 INV A	111.55 C-122022		TRANSFORMER
030074 REINDERS	2049681	0	2023 3 INV A	108.65 C-122022		MINI -LIGHTS
030074 REINDERS	2049716	0	2023 3 INV A	150.13 C-122022		DATA PARTS
				467.00		
030629 AMAZON CAPITAL	1T'KKMNVKXJJ	0	2023 3 INV A	209.97 C-122022		TRANSMITTER-SOUTHER
030629 AMAZON CAPITAL	1XJXD97XT'7N6	0	2023 3 CRM A	-46.99 C-122022		CREDIT MEMO-OUTDOOR
				162.98		
			ACCOUNT TOTAL	2,008.55		
411 622100			PROFESSIONAL SERVICES			
015807 R.C. SYSTEMS, INC	19395	0	2023 3 INV A	2,300.00 C-122022		CONTRACT RENEWAL FO
			ACCOUNT TOTAL	2,300.00		
411 626000			UTILITIES			

12/15/2022 12:59
1540spri

CITY OF SOUTHAVEN
FY 2023 CLAIMS DOCKET C-122022

P 19
apinv gla

YEAR/PERIOD: 2023/1 TO 2023/3	ACCOUNT/VENDOR	INVOICE	PO	YEAR/PR	TYP	S	WARRANT	CHECK	DESCRIPTION
	031719 GOTO COMMUNICATIONS	IN7101578423	0	2023 3	INV	A	25.96	C-122022	PHONES - GREENBROOK
				ACCOUNT TOTAL			25.96		
411	627901			UMPIRES					
	002574 CARSON MICHAEL A	12-13-2022	0	2023 3	INV	A	280.00	C-122022	INDOOR SOCCER PAYRO
	015544 KLINCK MATTHEW	12-13-2022	0	2023 3	INV	A	70.00	C-122022	INDOOR SOCCER PAYRO
	015545 KLINCK ZACHARY A	12-13-2022	0	2023 3	INV	A	915.00	C-122022	INDOOR SOCCER PAYRO
	015810 MEARS MICHAEL	12-13-2022	0	2023 3	INV	A	280.00	C-122022	INDOOR SOCCER PAYRO
	018253 CHAN DAVID	12-13-2022	0	2023 3	INV	A	175.00	C-122022	INDOOR SOCCER PAYRO
	018255 PHILLIPS ERIC	12-13-2022	0	2023 3	INV	A	280.00	C-122022	INDOOR SOCCER PAYRO
	025653 CORREA RAFAEL	12-13-2022	0	2023 3	INV	A	350.00	C-122022	INDOOR SOCCER PAYRO
	028218 COX III DAVID ROYAL	12-13-2022	0	2023 3	INV	A	140.00	C-122022	INDOOR SOCCER PAYRO
	031322 VASQUEZ GEORGE	12-13-2022	0	2023 3	INV	A	280.00	C-122022	INDOOR SOCCER PAYRO
	036078 BEAL BLAKE AUSTIN	12-11-2022	0	2023 3	INV	A	70.00	C-122022	SOFTBALL OFFICALS/O
	036319 TOWELL ETHAN	12-13-2022	0	2023 3	INV	A	490.00	C-122022	INDOOR SOCCER PAYRO
	036350 SIMPSON SPENSER	12-13-2022	0	2023 3	INV	A	420.00	C-122022	INDOOR SOCCER PAYRO
				ACCOUNT TOTAL			3,750.00		
				ORG 411	TOTAL		30,090.13		
412				PARK TOURNAMENTS					
412	612400			RESELL / CONCESSION EXPENSE					
	003011 M & M PROMOTIONS	97296	0	2023 3	INV	A	440.00	C-122022	SOFTBALL RETAIL - T
	003011 M & M PROMOTIONS	97551	0	2023 3	INV	A	1,117.50	C-122022	JUNE JAMBORE SHIRTS
							1,557.50		
	003538 SYSCO CORPORATION	314876886	0	2023 3	INV	A	524.62	C-122022	CONCESSIONS
	003538 SYSCO CORPORATION	314880559	0	2023 3	INV	A	170.85	C-122022	CONCESSIONS - FOOD/
							695.47		
	035925 KB ENTERPRISES	63748594	0	2023 3	INV	A	283.50	C-122022	MINI MELTS FOR CONC
				ACCOUNT TOTAL			2,536.47		
412	626102			PROMOTIONS					
	025894 SPORTSENGINE	INV01472022	0	2023 3	INV	A	749.00	C-122022	SOCCER WEBSITE ANNU
	025894 SPORTSENGINE	INV01485413	0	2023 3	INV	A	2,098.00	C-122022	SOCCER WEB SITE

12/15/2022 12:59
1540spri

CITY OF SOUTHAVEN
FY 2023 CLAIMS DOCKET C-122022

P 20
apinvgl

YEAR/PERIOD:	2023/1	TO	2023/3								
ACCOUNT/VENDOR		INVOICE	PO	YEAR/PR	TYP	S	WARRANT	CHECK	DESCRIPTION		
										2,847.00	
									ACCOUNT TOTAL	2,847.00	
				ORG 412		TOTAL				5,383.47	
511				MUNICIPAL CODE ENFORCEMENT							
511	610400			OFFICE SUPPLIES							
	004975	BAREFIELD WORKPLACE	1164049	0	2023	3	INV	A	23 CALENDARS & OFFI	6.00 C-122022	
									ACCOUNT TOTAL	6.00	
511	611000			MATERIALS							
	001102	SOUTHAVEN SUPPLY	163263	0	2023	3	INV	A	MATERIALS	28.31 C-122022	
	010919	TRACTOR SUPPLY CREDI	2088373396	0	2023	3	INV	A	MATERIALS - TIDY CA	86.61 C-122022	
									ACCOUNT TOTAL	114.92	
511	614900			FEED FOR ANIMALS							
	012713	HILL'S PET NUTRITION	243991620	0	2023	3	INV	A	FEED ANIMALS	152.31 C-122022	
	012713	HILL'S PET NUTRITION	243991621	0	2023	3	INV	A	FEED ANIMALS	152.31 C-122022	
	012713	HILL'S PET NUTRITION	244058339	0	2023	3	INV	A	FEED ANIMALS	167.02 C-122022	
	012713	HILL'S PET NUTRITION	639924450	0	2023	3	INV	A	FEED ANIMALS	14.71 C-122022	
	012713	HILL'S PET NUTRITION	639968814	0	2023	3	INV	A	FEED ANIMALS	14.71 C-122022	
										501.06	
									ACCOUNT TOTAL	501.06	
511	622100			PROFESSIONAL SERVICES							
	000801	STERICYCLE INC	4011367814	0	2023	3	INV	A	PROF. SERVICES	774.36 C-122022	
	028872	PRECIOUS PAWS ANIMAL	1791	0	2023	3	INV	A	PROF. SERVICES	773.50 C-122022	
									ACCOUNT TOTAL	1,547.86	
				ORG 511		TOTAL				2,169.84	
902				EXPENSE ACCOUNTS							
902	620902			FACILITIES MANAGEMENT							
	000021	A-1 FIRE PROTECTION	62436	0	2023	3	INV	A	FIRE EXTINGUISHERS	252.00 C-122022	
	000021	A-1 FIRE PROTECTION	62437	0	2023	3	INV	A	FIRE EXTINGUISHERS	2,715.00 C-122022	
	000021	A-1 FIRE PROTECTION	62441	0	2023	3	INV	A	FIRE EXTINGUISHERS	1,254.00 C-122022	
	000021	A-1 FIRE PROTECTION	62442	0	2023	3	INV	A	FIRE EXTINGUISHERS	336.00 C-122022	
	000021	A-1 FIRE PROTECTION	62443	0	2023	3	INV	A	FIRE EXTINGUISHERS	230.00 C-122022	
	000021	A-1 FIRE PROTECTION	62444	0	2023	3	INV	A	FIRE EXTINGUISHERS	170.00 C-122022	
	000021	A-1 FIRE PROTECTION	62447	0	2023	3	INV	A	FIRE EXTINGUISHERS	857.00 C-122022	
										5,814.00	

12/15/2022 12:59
1540spri

CITY OF SOUTHAVEN
FY 2023 CLAIMS DOCKET C-122022

P 21
apinvgl

YEAR/PERIOD: 2023/1 TO 2023/3	ACCOUNT/VENDOR	INVOICE	PO	YEAR/PR	TYP	S	WARRANT	CHECK	DESCRIPTION
	000402	CURRY JANITORIAL SER 877374	0	2023	3	INV A	425.00	C-122022	DECEMBER 2022 FBI O
	006685	DEX IMAGING AR8594804	0	2023	3	INV A	215.43	C-122022	MP8510 - 4TH FLOOR
	028454	CHANDLERS LAWN SER 100221	0	2023	3	INV A	28,500.00	C-122022	NOV. 2022 LAWN MAIN
	028454	CHANDLERS LAWN SER 100222	0	2023	3	INV A	645.00	C-122022	LAWN MAINT. @ I-55/
	028454	CHANDLERS LAWN SER 100223	0	2023	3	INV A	1,450.00	C-122022	NOV. 2022 LAWN MAIN
							30,595.00		
	031070	FRANCE PAINT CO 12-13-2022	23000118	2023	3	INV A	15,958.00	C-122022	FIRE STATION 1 INTE
	032120	FACILITIES PREFORMAN FPG-SOUTHAVEN-0922	0	2023	3	INV A	7,014.14	C-122022	SEPT. 2022 CLEANING
	032120	FACILITIES PREFORMAN FPG-SOUTHAVEN-1022	0	2023	3	INV A	7,309.43	C-122022	OCT. 2022 CLEANING
	032120	FACILITIES PREFORMAN FPG-SOUTHAVEN-1122	0	2023	3	INV A	7,309.43	C-122022	NOV. 2022 CLEANING
							21,633.00		
						ACCOUNT TOTAL	74,640.43		
902	622100					PROFESSIONAL SERVICES			
	018221	CIVIL-LINK, LLC 76511	0	2023	3	INV A	2,476.64	C-122022	GETWELL RD MULTIUSE
	018221	CIVIL-LINK, LLC 76513	0	2023	3	INV A	1,760.71	C-122022	RASCO & GREENBROOK
							4,237.35		
	024871	WAGWORKS 1122-TR44884	0	2023	3	INV A	251.43	C-122022	NOV. 2022-COBRA ADM
						ACCOUNT TOTAL	4,488.78		
902	625100					STREET IMPROVEMENT			
	000759	LEHMAN ROBERTS CO 21049-11	0	2023	3	INV A	736,830.31	C-122022	OCTOBER 2022 JOB #2
	009591	TRI FIRMA 6452QB	0	2023	3	INV A	11,459.04	C-122022	TCHULAHOMA ROAD REP
	018221	CIVIL-LINK, LLC 76517	0	2023	3	INV A	20,247.50	C-122022	CITY PAVEMENT PRESE
						ACCOUNT TOTAL	768,536.85		
902	625103					DRAINAGE MAINTENANCE			
	009591	TRI FIRMA 6460	0	2023	3	INV A	23,462.02	C-122022	8910 DEERCREEK LANE
	009591	TRI FIRMA 6463	0	2023	3	INV A	2,729.17	C-122022	7269 SUNFLOWER COVE
	009591	TRI FIRMA 6464	0	2023	3	INV A	1,635.35	C-122022	MARKSTON DRIVE @ CH
	009591	TRI FIRMA 6469	0	2023	3	INV A	8,827.17	C-122022	4380 JESSICA DRIVE
	009591	TRI FIRMA 6470	0	2023	3	INV A	11,816.35	C-122022	MEADOW LANE DRIVE -
							48,470.06		
						ACCOUNT TOTAL	48,470.06		
902	625150					DRAINAGE IMPROVEMENT			
	009591	TRI FIRMA 6461	0	2023	3	INV A	22,125.98	C-122022	8910 DEERCREEK LANE

12/15/2022 12:59
1540spri

CITY OF SOUTHAVEN
FY 2023 CLAIMS DOCKET C-122022

P 22
apinvgl

YEAR/PERIOD: 2023/1 TO 2023/3	ACCOUNT/VENDOR	INVOICE	PO	YEAR/PR	TYP	S	WARRANT	CHECK	DESCRIPTION
	018221 CIVIL-LINK, LLC	76512	0	2023 3	INV	A	7,449.29	C-122022	LCNOI EROSION CONTR
	018221 CIVIL-LINK, LLC	76518	0	2023 3	INV	A	5,941.67	C-122022	DRAINAGE IMPROVEMEN
	018221 CIVIL-LINK, LLC	76519	0	2023 3	INV	A	2,925.16	C-122022	HORN LAKE BRIDGE RE
	018221 CIVIL-LINK, LLC	76521	0	2023 3	INV	A	2,741.45	C-122022	CARRIAGE HILLS DRAI
	018221 CIVIL-LINK, LLC	76522	0	2023 3	INV	A	8,827.11	C-122022	AUTUMN WOODS DRAIN
							27,884.68		
							ACCOUNT TOTAL		50,010.66
902	625220								STREET MAINTENANCE
	009591 TRI FIRMA	6465	0	2023 3	INV	A	2,335.07	C-122022	3373 CHAMPION HILLS
	009591 TRI FIRMA	6466	0	2023 3	INV	A	2,952.65	C-122022	3438 WOODCUTTER DRI
	009591 TRI FIRMA	6467	0	2023 3	INV	A	7,660.55	C-122022	8151/8152 PARK PIKE
	009591 TRI FIRMA	6468	0	2023 3	INV	A	5,590.25	C-122022	8226 PARK PIKE/1569
	009591 TRI FIRMA	6471	0	2023 3	INV	A	38,830.60	C-122022	3220 SHADY OAKS DR.
							57,369.12		
							ACCOUNT TOTAL		57,369.12
							ORG 902 TOTAL		1,003,515.90
904									LITIGATION
904	622100								PROFESSIONAL SERVICES
	017086 BUTLER SNOW	10361214	0	2023 3	INV	A	25,001.60	C-122022	GENERAL SERVICE THR
	017086 BUTLER SNOW	10361217	0	2023 3	INV	A	315.00	C-122022	LITIGATION MATTERS
							25,316.60		
							ACCOUNT TOTAL		25,316.60
904	629100								CLAIMS PAYMENTS
	011139 TRAVELERS	619558	0	2023 3	INV	A	2,362.50	C-122022	CLAIM #A2F0137 FOR
							2,362.50		
							ACCOUNT TOTAL		2,362.50
							ORG 904 TOTAL		27,679.10
905									LIABILITY INSURANCE
905	602700								WORKMAN'S COMP INSUR
	030408 ARTHUR J GALLAGHER	4342774	0	2023 3	INV	A	160,002.00	C-122022	22/23 WC RENEWAL 2
	030408 ARTHUR J GALLAGHER	4342775	0	2023 3	INV	A	160,002.00	C-122022	22/23 WC - RENEWAL
							320,004.00		
							ACCOUNT TOTAL		320,004.00
905	629300								INSURANCE-LIABILITY
	030408 ARTHUR J GALLAGHER	4433491	0	2023 3	INV	A	148.00	C-122022	21 22 AUTO - AUDIT

12/15/2022 12:59
1540spri

CITY OF SOUTHAVEN
FY 2023 CLAIMS DOCKET C-122022

P 23
apinvgl

YEAR/PERIOD: 2023/1 TO 2023/3
ACCOUNT/VENDOR INVOICE

PO

YEAR/PR TYP S

WARRANT

CHECK

DESCRIPTION

ACCOUNT TOTAL 148.00

ORG 905 TOTAL 320,152.00

=====

FUND 0010 GENERAL FUND TOTAL: 2,058,491.20

=====

12/15/2022 12:59
1540spri

CITY OF SOUTHAVEN
FY 2023 CLAIMS DOCKET C-122022

P 24
apinvgl

YEAR/PERIOD: 2023/1 TO 2023/3								
ACCOUNT/VENDOR	INVOICE	PO	YEAR/PR	TYP	S	WARRANT	CHECK	DESCRIPTION
711								BOND PROJECT EXPENSES
711	625850							MEDLINE PEPPERCHASE
000212	FERRELL PAVING INC	PAYAPP-11	0	2023	3 INV A	134,320.92	C-122022	PEPPERCHASE DRIVE E
018221	CIVIL-LINK, LLC	76520	0	2023	3 INV A	6,735.02	C-122022	PEPPERCHASE DRIVE E
					ACCOUNT TOTAL	141,055.94		
711	640220							FIRE STATION 5
016177	A2H	53938	0	2023	3 INV A	3,338.60	C-122022	ARCHITECTURAL SERVI
					ACCOUNT TOTAL	3,338.60		
711	640900 07002							AMPHITHEATER
005831	URBANARCH ASSOC PC	21016-A13	0	2023	3 INV A	20,834.58	C-122022	BANKPLUS AMPHITHEAT
					ACCOUNT TOTAL	20,834.58		
711	640965							GETWELL ROAD SOUTH 18
018221	CIVIL-LINK, LLC	76514	0	2023	3 INV A	6,022.93	C-122022	GETWELL ROAD WIDENI
018221	CIVIL-LINK, LLC	76515	0	2023	3 INV A	4,692.20	C-122022	GETWELL ROAD WIDENI
						10,715.13		
					ACCOUNT TOTAL	10,715.13		
					ORG 711 TOTAL	175,944.25		
=====								
FUND 0100 BOND FUNDED CAP PROJ						TOTAL:		175,944.25
=====								

12/15/2022 12:59
 1540spri

 CITY OF SOUTHAVEN
 FY 2023 CLAIMS DOCKET C-122022

 P 25
 apinvgl

YEAR/PERIOD: 2023/1 TO 2023/3								
ACCOUNT/VENDOR	INVOICE	PO	YEAR/PR	TYP	S	WARRANT	CHECK	DESCRIPTION
611			SPECIAL ASSESSMENTS EXPEND					
611	623800 90017		PARK IMPROVEMENTS					
005831	URBANARCH ASSOC PC	22055-A2	0	2023	3 INV A	1,724.01	C-122022	SNOWDEN GROVE EXTER
023861	JAYCON DEVELOPMENT	PAYAPP1	0	2023	3 INV A	55,132.30	C-122022	SNOWDEN GROVE B' BAL
				ACCOUNT TOTAL		56,856.31		
611	623801		NEIGHBORHOOD PARKS					
018221	CIVIL-LINK, LLC	76532	0	2023	3 INV A	14,320.84	C-122022	NEIGHBORHOOD PARKS
018221	CIVIL-LINK, LLC	76533	0	2023	3 INV A	6,565.77	C-122022	NEIGHBORHOOD PARKS,
						20,886.61		
				ACCOUNT TOTAL		20,886.61		
611	623802		ARENA PARKING LOT					
018221	CIVIL-LINK, LLC	76530	0	2023	3 INV A	2,326.92	C-122022	ARENA PARKING LOT E
018221	CIVIL-LINK, LLC	76531	0	2023	3 INV A	2,726.04	C-122022	ARENA PARKING LOT E
						5,052.96		
				ACCOUNT TOTAL		5,052.96		
611	626300		AMPHITHEATER MANAGEMENT					
017044	DESOTO COUNTY	12-14-2022	0	2023	3 INV A	8,333.33	C-122022	DECEMBER 2022 CONCE
				ACCOUNT TOTAL		8,333.33		
			ORG 611	TOTAL		91,129.21		
=====								
FUND 0240 TOURIST & CONVENTION						TOTAL:	91,129.21	
=====								

12/15/2022 12:59
1540spri

CITY OF SOUTHAVEN
FY 2023 CLAIMS DOCKET C-122022

P 26
apinv gla

YEAR/PERIOD: 2023/1 TO 2023/3	ACCOUNT/VENDOR	INVOICE	PO	YEAR/PR TYP S	WARRANT	CHECK	DESCRIPTION
0400				UTILITY FUND			
0400	211400			FEEES OWED TO NESBIT WATER ASSC			
	010365 NESBIT WATER	12-1-22	0	2023 3 INV A	3,096.00	C-122022	NOV. 2022 FEES COLL
				ACCOUNT TOTAL	3,096.00		
				ORG 0400 TOTAL	3,096.00		
811				UTILITY EXPENSE ACCOUNTS			
811	650905			DCRUA SEWER TREATMENT FEE			
	004646 DESOTO COUNTY REGION 2860		0	2023 3 INV A	87,127.25	C-122022	DEC. 2022 SEWER FEE
				ACCOUNT TOTAL	87,127.25		
811	651400			DCRUA UPGRADE TAP FEES			
	004646 DESOTO COUNTY REGION 12-2-22		0	2023 3 INV A	2,250.00	C-122022	NOV. 2022 COLLECTED
				ACCOUNT TOTAL	2,250.00		
811	651500			DCRUA TAP FEES			
	004646 DESOTO COUNTY REGION 12-2-22		0	2023 3 INV A	4,600.00	C-122022	NOV. 2022 COLLECTED
				ACCOUNT TOTAL	4,600.00		
				ORG 811 TOTAL	93,977.25		
815				UTILITY CAPITAL IMPROVEMENTS			
815	625300			EXTENSION & OTHER IMPROVEMENTS			
	009591 TRI FIRMA	6472	0	2023 3 INV A	97,551.24	C-122022	CENTRAL PARK SERER
	016939 ADVANCE ELECTRIC	27333	0	2023 3 INV A	9,490.00	C-122022	EMERGENCY REPLACEME
	018221 CIVIL-LINK, LLC	76526	0	2023 3 INV A	27,634.11	C-122022	FIRE SERVICE EXTENS
	018221 CIVIL-LINK, LLC	76527	0	2023 3 INV A	10,977.70	C-122022	UTILITY MAPPING AND
	018221 CIVIL-LINK, LLC	76529	0	2023 3 INV A	1,895.33	C-122022	LEAD AND COPPER SYS
					40,507.14		
				ACCOUNT TOTAL	147,548.38		
815	625305			SANITARY SEWER EXTENSION			
	018221 CIVIL-LINK, LLC	76525	0	2023 3 INV A	3,882.79	C-122022	SANITARY SEWER SERV
				ACCOUNT TOTAL	3,882.79		
815	625310			CAPITAL IMPROVEMENTS			
	031980 COMMERCIAL PAINTING	1656-1	23000062	2023 3 INV A	28,900.00	C-122022	DRYWALL PAINTING
				ACCOUNT TOTAL	28,900.00		
815	625310 1003			STARLANDING WATER SYS IM PH II			

12/15/2022 12:59
1540spri

CITY OF SOUTHAVEN
FY 2023 CLAIMS DOCKET C-122022

P 28
apinvgl

YEAR/PERIOD: 2023/1	TO 2023/3									
ACCOUNT/VENDOR	INVOICE	PO	YEAR/PR	TYP	S	WARRANT	CHECK	DESCRIPTION		
000989 ICM OF MEMPHIS	20127	0	2023 3	INV	A	1,560.00	C-122022	HOSE & PLUG		
001102 SOUTHAVEN SUPPLY	164581	0	2023 3	INV	A	1,100.12	C-122022	MISC SUPPLIES		
002869 VULCAN MATERIALS	51274321	0	2023 3	INV	A	1,253.50	C-122022	LIMESTONE		
002869 VULCAN MATERIALS	51274322	0	2023 3	INV	A	1,873.11	C-122022	LIMESTONE		
						3,126.61				
004246 HARBOR FREIGHT TOOLS	779170	0	2023 3	INV	A	259.98	C-122022	BODY REPAIR WORK FO		
004494 J R STEWART	36338	0	2023 3	INV	A	243.81	C-122022	COVER FOR PUMP STAT		
007304 O'REILLYS AUTO PARTS	1257-199348	0	2023 3	INV	A	49.99	C-122022	ARTIC FREEZE TRUCK		
007304 O'REILLYS AUTO PARTS	1257-210756	0	2023 3	INV	A	4.07	C-122022	LIGHTS (MINI BULB)		
						54.06				
013650 BATTERIES PLUS	P57053882	0	2023 3	INV	A	51.74	C-122022	BATTERIES		
030629 AMAZON CAPITAL	1GRPLHDQ1GJD	0	2023 3	INV	A	611.94	C-122022	#ANKP067K88KPB-GLOV		
030629 AMAZON CAPITAL	1GW46749DY67	0	2023 3	INV	A	861.68	C-122022	#ANKP067K88KPB-SAFE		
						1,473.62				
032986 CENTRO INC	258554	0	2023 3	INV	A	3,915.85	C-122022	TRANSMITTERS		
						ACCOUNT TOTAL				24,730.37
825 611100						CHEMICALS				
001146 IDEAL CHEMICAL	277070	0	2023 3	INV	A	2,853.75	C-122022	CHEMICALS FOR WHITW		
001146 IDEAL CHEMICAL	277071	0	2023 3	INV	A	2,853.75	C-122022	CHEMICALS FOR GETWE		
001146 IDEAL CHEMICAL	277318	0	2023 3	INV	A	467.50	C-122022	CHEMICALS FOR WHITW		
001146 IDEAL CHEMICAL	277319	0	2023 3	INV	A	3,087.50	C-122022	CHEMICALS FOR GREEN		
001146 IDEAL CHEMICAL	277320	0	2023 3	INV	A	1,932.00	C-122022	CHEMICALS FOR COLLE		
						11,194.50				
005073 MOMAR	PSI476723	0	2023 3	INV	A	2,073.47	C-122022	DEGREASER & DISINFE		
						ACCOUNT TOTAL				13,267.97
825 611300						MAINTENANCE VEHICLES				
000887 JIMMY GRAY CHEVROLET	500420	0	2023 3	INV	A	1,929.66	C-122022	REPAIRS TO TRUCK #8		
000979 SOUTHAVEN CAR CARE	41755	0	2023 3	INV	A	283.12	C-122022	ROUTINE MAINTENANCE		
001150 NAPA GENUINE PARTS C	845937	0	2023 3	INV	A	54.85	C-122022	WIPER BLADES TRUCK		
006706 LANDERS DODGE	340725	0	2023 3	INV	A	99.00	C-122022	ROUTINE MAINTENANCE		
007304 O'REILLYS AUTO PARTS	1257-199280	0	2023 3	INV	A	242.68	C-122022	BATTERY & LIGHT/TRU		

12/15/2022 12:59
1540spri

CITY OF SOUTHAVEN
FY 2023 CLAIMS DOCKET C-122022

P 29
apinvgl

YEAR/PERIOD: 2023/1 ACCOUNT/VENDOR	TO 2023/3 INVOICE	PO	YEAR/PR	TYP	S	WARRANT	CHECK	DESCRIPTION
007304 O'REILLYS AUTO PARTS	1257-210054	0	2023 3	INV	A	157.94	C-122022	MOTOR OIL - TRUCK #
						400.62		
015790 TRI STATE AUTO	11-29-2022	0	2023 3	INV	A	249.99	C-122022	REPAIR STROBES TRUC
015790 TRI STATE AUTO	11292022	0	2023 3	INV	A	100.00	C-122022	GPS REPAIR TRUCK #8
015790 TRI STATE AUTO	12052022	0	2023 3	INV	A	100.00	C-122022	GPS REPAIR
						449.99		
024154 DISCOUNT TIRE	1329689	0	2023 3	INV	A	227.37	C-122022	TIRE FOR TRUCK #846
029563 LANDERS FORD SOUTH	146742C	0	2023 3	INV	A	84.93	C-122022	OIL CHANGE & MISC W
						ACCOUNT TOTAL		3,529.54
825 612200								MAINTENANCE EQUIPMENT & BUILD
000883 AMERICAN TIRE REPAIR	161730	0	2023 3	INV	A	875.32	C-122022	TIRE REPAIR FOR DUM
027972 MID SOUTH SEPTIC LLC	58045	0	2023 3	INV	A	1,260.00	C-122022	CAMERA REPAIR
						ACCOUNT TOTAL		2,135.32
825 612500								UNIFORMS
030629 AMAZON CAPITAL	1TPRYDJD9VKF	0	2023 3	INV	A	719.82	C-122022	#ANKP067K88KPB-UNIF
						ACCOUNT TOTAL		719.82
825 622100								PROFESSIONAL SERVICES
011134 WHITFIELD	85516	0	2023 3	INV	A	375.00	C-122022	REPAIRS @ BROOKHAVE
011134 WHITFIELD	85591	0	2023 3	INV	A	187.50	C-122022	SERVICE CALL WHITWO
						562.50		
018221 CIVIL-LINK, LLC	76524	0	2023 3	INV	A	4,725.00	C-122022	UTILITIES RPR
019700 CHOICE TOWING	73552	0	2023 3	INV	A	50.00	C-122022	TOW TRUCK #822
019700 CHOICE TOWING	73979	0	2023 3	INV	A	50.00	C-122022	TOW TRUCK #857
019700 CHOICE TOWING	74115	0	2023 3	INV	A	50.00	C-122022	TOW TRUCK #855
						150.00		
020449 FINAL TOUCH SECURITY	75220	0	2023 3	INV	A	100.00	C-122022	SERVICE CALL TO DOR
032345 ISI WATER COMPANY	6	0	2023 3	INV	A	23,751.01	C-122022	JUNE 2022 - NOV. 20
						ACCOUNT TOTAL		29,288.51
825 624500								LICENSES & MISCELLANEOUS FEES
001363 HEFFNER MISTY	122129	0	2023 3	INV	A	26.00	C-122022	SEWER EASEMENTS
						ACCOUNT TOTAL		26.00

12/15/2022 12:59
1540spri

CITY OF SOUTHAVEN
FY 2023 CLAIMS DOCKET C-122022

P 30
apinvgl

YEAR/PERIOD: 2023/1 TO 2023/3
ACCOUNT/VENDOR INVOICE

PO

YEAR/PR TYP S

WARRANT

CHECK

DESCRIPTION

ORG 825 TOTAL 73,697.53

=====

FUND 0400 UTILITY FUND TOTAL: 510,761.70

=====



12/15/2022 12:59
1540spri

CITY OF SOUTHAVEN
FY 2023 CLAIMS DOCKET C-122022

P 31
apinvgl

YEAR/PERIOD: 2023/1 TO 2023/3	ACCOUNT/VENDOR	INVOICE	PO	YEAR/PR TYP S	WARRANT	CHECK	DESCRIPTION
850				MAINTENANCE EXPENSES			
850	622100			PROFESSIONAL SERVICES			
	000297 GRIFFITH TOWING LLC	70648	0	2023 3 INV A	450.00	C-122022	TOWING FOR RB
	007500 SWEEPING CORPORATION	SCA093869	0	2023 3 INV A	22,068.46	C-122022	SWEEPING SERV PER C
				ACCOUNT TOTAL	22,518.46		
850	622107			RECYCLING SERVICES			
	008127 WASTE CONNECTIONS OF	6010-11-22-001	0	2023 3 INV A	261,460.36	C-122022	NOV. 2022 TRASH & R
	008127 WASTE CONNECTIONS OF	6735673W010	0	2023 3 INV A	1,827.78	C-122022	6010-1151186/ @ 736
					263,288.14		
				ACCOUNT TOTAL	263,288.14		
				ORG 850 TOTAL	285,806.60		
=====							
	FUND 0450 SANITATION FUND			TOTAL:	285,806.60		
=====							

** END OF REPORT - Generated by Sonya Pride **

12/15/2022 12:58
1540spr1

CITY OF SOUTHAVEN
FY 2023 CLAIMS DOCKET D-122022

P 1
apinvgl

YEAR/PERIOD: 2023/1 TO 2023/3								
ACCOUNT/VENDOR	INVOICE	PO	YEAR/PR	TYP	S	WARRANT	CHECK	DESCRIPTION
120								ARTS AND CULTURAL AFFAIRS
120	626900							TRAVEL & TRAINING
001339	CREDIT CARD CENTER	12-14-22	0	2023	3 INV P	196.00	D-122022	200756 CANDENCE BANK CREDI
						196.00		ACCOUNT TOTAL
						196.00		ORG 120 TOTAL
125								COURT DEPARTMENT
125	621500							COURT BOND REFUND
036359	MINTON TYLANESHIATA	9-14-2022	0	2023	3 INV P	150.00	D-122022	200432 RE-ISSUE/CASH BOND
						150.00		ACCOUNT TOTAL
125	621505							COURT SUPPLIES
007504	PAETEC	75328136	0	2023	3 INV A	104.25	D-122022	75100820 - DECEMBER
						104.25		ACCOUNT TOTAL
						254.25		ORG 125 TOTAL
145								DEPARTMENT OF FINANCE & ADMIN
145	622100							PROFESSIONAL SERVICES
022719	UMB CARD SERVICES	122622-09	0	2023	3 INV P	108.00	D-122022	200764 UMB CHARGES- CONTRO
						108.00		ACCOUNT TOTAL
						108.00		ORG 145 TOTAL
150								INFORMATION TECHNOLOGY
150	610500							COMPUTERS
022719	UMB CARD SERVICES	122622-58	0	2023	3 INV P	278.49	D-122022	200764 UMB CHARGES 0058
						278.49		ACCOUNT TOTAL
150	610550							NETWORK CONNECTIVITY
007504	PAETEC	75328136	0	2023	3 INV A	11,888.81	D-122022	75100820 - DECEMBER
						11,888.81		ACCOUNT TOTAL
150	625700							TELEPHONE/POSTAGE
001137	FEDEX	7-969-67788	0	2023	3 INV A	38.37	D-122022	SHIPPING RETURN - 3
						38.37		ACCOUNT TOTAL
						12,205.67		ORG 150 TOTAL
155								CITY CLERK
155	622100							PROFESSIONAL SERVICES
022719	UMB CARD SERVICES	122622-09	0	2023	3 INV P	327.73	D-122022	200764 UMB CHARGES- CONTRO
						327.73		ACCOUNT TOTAL

12/15/2022 12:58
 1540apri

 CITY OF SOUTHAVEN
 FY 2023 CLAIMS DOCKET D-122022

 P 2
 apinv gla

YEAR/PERIOD:	2023/1	TO	2023/3							
ACCOUNT/VENDOR		INVOICE	PO	YEAR/PR	TYP	S	WARRANT	CHECK	DESCRIPTION	
155	625700			TELEPHONE & POSTAGE						
007504	PAETEC	75328136	0	2023	3	INV A	596.34	D-122022	75100820 - DECEMBER	
022719	UMB CARD SERVICES	122622-09	0	2023	3	INV P	9.95	D-122022	200764 UMB CHARGES- CONTRO	
				ACCOUNT TOTAL			606.29			
				ORG 155		TOTAL	934.02			
180				PLANNING / ENGINEERING DEPT						
180	622100			PROFESSIONAL FEES						
030534	DATAFACTS	177318	0	2023	3	INV P	27.00	D-122022	200437 EMPLOYEE BACKGROUND	
				ACCOUNT TOTAL			27.00			
				ORG 180		TOTAL	27.00			
211				POLICE DEPARTMENT						
211	600100			SALARIES-ADMINISTRATION						
036743	PERCY CLIFTON M	12-2-2022	0	2023	3	INV P	1,021.40	D-122022	200439 PAYROLL SHORTAGE/MA	
				ACCOUNT TOTAL			1,021.40			
211	611300			MAINTENANCE VEHICLES						
000883	AMERICAN TIRE REPAIR	162021-S	0	2023	3	INV P	2,092.32	D-122022	200424 SHORT PAY - SHOP PA	
007304	O'REILLYS AUTO PARTS	1257-207020	0	2023	3	INV P	62.99	D-122022	200435 RE-ISSUE/3180 MRAP	
007304	O'REILLYS AUTO PARTS	1791-201400	0	2023	3	INV P	4.23	D-122022	200435 RE-ISSUE/3189 TUBIN	
							67.22			
032616	TC AUTO SALES	11302022	0	2023	3	INV P	300.00	D-122022	200770 3177 REPAIRS	
032616	TC AUTO SALES	113022	0	2023	3	INV P	3,440.00	D-122022	200770 3220 REPAIRS	
							3,740.00			
				ACCOUNT TOTAL			5,899.54			
211	622100			PROFESSIONAL SERVICES						
030534	DATAFACTS	177318	0	2023	3	INV P	81.00	D-122022	200437 EMPLOYEE BACKGROUND	
				ACCOUNT TOTAL			81.00			
211	625700			TELEPHONE & POSTAGE						
001137	FEDEX	7-968-88452	0	2023	3	INV A	29.08	D-122022	DEPT. OF NAVY (SPD)	
001167	AT&T MOBILITY	7424-112722	0	2023	3	INV P	5,357.53	D-122022	200760 287288007424-UT SCA	
007504	PAETEC	75328136	0	2023	3	INV A	189.19	D-122022	75100820 - DECEMBER	
018521	SOUTHERN TELECOMMUNI	11-29-2022	0	2023	3	INV P	592.12	D-122022	200775 #2480 - 6623934898/	

12/15/2022 12:58
1540spri

CITY OF SOUTHAVEN
FY 2023 CLAIMS DOCKET D-122022

P 3
apinvgl

YEAR/PERIOD: 2023/1 TO 2023/3									
ACCOUNT/VENDOR	INVOICE	PO	YEAR/PR	TYP	S	WARRANT	CHECK	DESCRIPTION	
					ACCOUNT TOTAL				6,167.92
211	626000				UTILITIES				
001145	ATMOS ENERGY	6621-112122	0	2023	3 INV P	95.16	D-122022	200772 3020696621 - 6450 G	
001145	ATMOS ENERGY	6889-120122	0	2023	3 INV P	545.02	D-122022	200772 3017116889 - 8691 N	
						640.18			
					ACCOUNT TOTAL				640.18
211	626102				PUBLIC RELATIONS				
022719	UMB CARD SERVICES	122622-09	0	2023	3 INV P	200.62	D-122022	200764 UMB CHARGES- CONTRO	
					ACCOUNT TOTAL				200.62
211	626900				TRAVEL & TRAINING				
001339	CREDIT CARD CENTER	12-14-22	0	2023	3 INV P	1,974.00	D-122022	200756 CANDENCE BANK CREDI	
					ACCOUNT TOTAL				1,974.00
211	630400				MACHINERY & EQUIPMENT				
013136	AT&T	1878-112322	0	2023	3 INV P	8,036.00	D-122022	200771 662 M10-7046 001 18	
					ACCOUNT TOTAL				8,036.00
					ORG 211 TOTAL				24,020.66
					FIRE DEPARTMENT				
290	611300				MAINTENANCE VEHICLES				
007304	O'REILLYS AUTO PARTS	1791-202181	0	2023	3 INV P	42.46	D-122022	200435 RE-ISSUE/2 SPARK PL	
007304	O'REILLYS AUTO PARTS	1791-202859	0	2023	3 INV P	14.99	D-122022	200435 RE-ISSUE/1 GALLON A	
						57.45			
					ACCOUNT TOTAL				57.45
290	612200				MAINTENANCE EQUIPMENT & BUILD				
022719	UMB CARD SERVICES	122622-09	0	2023	3 INV P	123.95	D-122022	200764 UMB CHARGES- CONTRO	
030049	AVON PROTECTION SYS	RA-6604	0	2023	3 INV P	704.00	D-122022	200440 THERMAL CAMERA REPA	
					ACCOUNT TOTAL				827.95
290	625700				TELEPHONE & POSTAGE				
001137	FEDEX	7-948-24766	0	2023	3 INV P	30.19	D-122022	200438 SHIPPING E-3 THERMA	
001167	AT&T MOBILITY	3065-112722	0	2023	3 INV A	1,712.84	D-122022	287288053065 - SFD	
007504	PAETEC	75328136	0	2023	3 INV A	81.87	D-122022	75100820 - DECEMBER	
					ACCOUNT TOTAL				1,824.90

12/15/2022 12:58
1540spri

CITY OF SOUTHAVEN
FY 2023 CLAIMS DOCKET D-122022

P 4
apinvgl

YEAR/PERIOD: 2023/1 TO 2023/3										
ACCOUNT/VENDOR	INVOICE	PO	YEAR/PR	TYP	S	WARRANT	CHECK	DESCRIPTION		
290	626000							UTILITIES		
000966	ENTERGY	10017084365	0	2023	3 INV A	977.76	D-122022	15374952 - 6050 ELM		
000966	ENTERGY	90007358292	0	2023	3 INV A	1,390.21	D-122022	15021074 - 6450 GET		
						2,367.97				
001145	ATMOS ENERGY	4569-112122	0	2023	3 INV P	563.13	D-122022	200425	3020654569 - 6450 G	
001145	ATMOS ENERGY	9368-120222	0	2023	3 INV P	885.71	D-122022	200766	3016939368-1940 STA	
						1,448.84				
						ACCOUNT TOTAL		3,816.81		
						ORG 290		TOTAL 6,527.11		
311								PUBLIC WORKS DEPARTMENT		
311	611300							MAINTENANCE VEHICLES		
007304	O'REILLYS AUTO PARTS	6399-129547	0	2023	3 INV P	72.50	D-122022	200435	RE-ISSUE/MAT. FOR S	
007304	O'REILLYS AUTO PARTS	6399-130092	0	2023	3 INV P	44.46	D-122022	200435	RE-ISSUE/MAT. FOR S	
007304	O'REILLYS AUTO PARTS	6399-130095	0	2023	3 INV P	12.15	D-122022	200435	RE-ISSUE/MAT. FOR S	
007304	O'REILLYS AUTO PARTS	6399-130671	0	2023	3 INV P	3.49	D-122022	200435	RE-ISSUE/MAT. FOR S	
007304	O'REILLYS AUTO PARTS	6399-131608	0	2023	3 INV P	82.45	D-122022	200435	RE-ISSUE/MAT. FOR S	
						215.05				
						ACCOUNT TOTAL		215.05		
311	625700							TELEPHONE & POSTAGE		
007504	PAETEC	75328136	0	2023	3 INV A	76.00	D-122022	75100820 - DECEMBER		
						ACCOUNT TOTAL		76.00		
311	626000							UTILITIES		
001145	ATMOS ENERGY	4805-112222	0	2023	3 INV P	207.45	D-122022	200755	4029104805 - 7320 H	
001145	ATMOS ENERGY	6196-112222	0	2023	3 INV P	559.59	D-122022	200755	3016966196 - 5813 P	
001145	ATMOS ENERGY	6445-112222	0	2023	3 INV P	748.24	D-122022	200755	3016966445 - 5813 P	
001145	ATMOS ENERGY	6721-112222	0	2023	3 INV P	468.37	D-122022	200755	3016966721 - 5813 P	
						1,983.65				
001388	HORN LAKE WATER ASSO	122022	0	2023	3 INV A	504.40	D-122022	030257000 - 5813 PE		
						ACCOUNT TOTAL		2,488.05		
						ORG 311		TOTAL 2,779.10		
315								CITY TRAFFIC AND STREETS LIGHT		
315	626000							UTILITIES		
000966	ENTERGY	185006968730	0	2023	3 INV P	138.72	D-122022	200758	16330888 - GOODMAN	
000966	ENTERGY	190005995604	0	2023	3 INV P	41.52	D-122022	200758	129563102 - 426 STA	
000966	ENTERGY	385004738987	0	2023	3 INV P	138.72	D-122022	200758	19041425 - GOODMAN	

12/15/2022 12:58
1540spri

CITY OF SOUTHAVEN
FY 2023 CLAIMS DOCKET D-122022

P 5
apinvgl

YEAR/PERIOD: 2023/1 TO 2023/3	ACCOUNT/VENDOR	INVOICE	PO	YEAR/PR	TYP	S	WARRANT	CHECK	DESCRIPTION
	000966	ENTERGY	475004113712	0	2023	3 INV P	249.79	D-122022	200758 100253780 - GOODMAN
							568.75		
	001105	NORTHCENTRAL ELECTRI	7013-112322	0	2023	3 INV A	.72	D-122022	59247013 - 3750 FRE
	001105	NORTHCENTRAL ELECTRI	7017-120122	0	2023	3 INV A	31.43	D-122022	59247017 - STATELIN
	001105	NORTHCENTRAL ELECTRI	7018-112322	0	2023	3 INV A	2.81	D-122022	59247018 - GOODMAN
							34.96		
						ACCOUNT TOTAL	603.71		
						ORG 315 TOTAL	603.71		
411						PARKS DEPARTMENT			
411	613400					COMMUNITY EVENTS			
	001137	FEDEX	7-962-51312	0	2023	3 INV P	15.18	D-122022	200761 SHIPPED A BAD PART
						ACCOUNT TOTAL	15.18		
411	622100					PROFESSIONAL SERVICES			
	036745	STRONG LIGHTING	SO23172	0	2023	3 INV P	91,720.00	D-122022	200763 SPOTLIGHTS FOR BANK
						ACCOUNT TOTAL	91,720.00		
411	625700					TELEPHONE & POSTAGE			
	018521	SOUTHERN TELECOMMUNI	11-29-2022	0	2023	3 INV P	152.18	D-122022	200775 #2480 - 6623934898/
						ACCOUNT TOTAL	152.18		
411	626000					UTILITIES			
	001105	NORTHCENTRAL ELECTRI	7015-111522	0	2023	3 INV P	31.73	D-122022	200434 59247015 - 3656 PIN
	001105	NORTHCENTRAL ELECTRI	7015-112322	0	2023	3 INV P	.51	D-122022	200773 59247015 - 3656 PIN
	001105	NORTHCENTRAL ELECTRI	7016-111522	0	2023	3 INV P	540.62	D-122022	200434 59247016 - 3656 PIN
							572.86		
	001145	ATMOS ENERGY	3332-112322	0	2023	3 INV P	5,200.90	D-122022	200436 3015253332 - 7360 H
	001145	ATMOS ENERGY	7945-120122	0	2023	3 INV P	1,471.18	D-122022	200766 3015017945- 8710 NO
	001145	ATMOS ENERGY	80559-120522	0	2023	3 INV P	274.38	D-122022	200772 4027080559 - 3750 F
	001145	ATMOS ENERGY	8239-112122	0	2023	3 INV P	176.80	D-122022	200425 3015018239 - 6070 S
							7,123.26		
	013136	AT&T	1875-112822	0	2023	3 INV P	44.40	D-122022	200759 662 280-0258 535 18
	016529	DIRECTV	21298039X221129	0	2023	3 INV P	190.44	D-122022	200757 021298039 - TV SERV
	016529	DIRECTV	46471734X221205	0	2023	3 INV A	157.28	D-122022	46471734 - TV SERVI
							347.72		
						ACCOUNT TOTAL	8,088.24		

12/15/2022 12:58
1540spri

CITY OF SOUTHAVEN
FY 2023 CLAIMS DOCKET D-122022

P 6
apinvgl

YEAR/PERIOD: 2023/1 TO 2023/3											
ACCOUNT/VENDOR	INVOICE	PO	YEAR/PR	TYP	S	WARRANT	CHECK	DESCRIPTION			
		ORG 411	TOTAL			99,975.60					
412	PARK TOURNAMENTS										
412	626102	PROMOTIONS									
001339	CREDIT CARD CENTER	12-14-22	0	2023	3 INV P	458.00	D-122022	200756	CANDENCE BANK CREDI		
ACCOUNT TOTAL						458.00					
		ORG 412	TOTAL			458.00					
902	EXPENSE ACCOUNTS										
902	620902	FACILITIES MANAGEMENT									
000966	ENTERGY	130005819962	0	2023	3 INV P	86.09	D-122022	200429	15991573 - 8710 NOR		
000966	ENTERGY	130005820031	0	2023	3 INV P	56.13	D-122022	200429	80540586 - 8889 NOR		
000966	ENTERGY	165006839909	0	2023	3 INV P	5,368.60	D-122022	200429	16831992 - 8700 NOR		
000966	ENTERGY	25007653902	0	2023	3 INV P	974.86	D-122022	200429	16004111 - 8889 NOR		
000966	ENTERGY	25007659837	0	2023	3 INV P	39.97	D-122022	200429	16832636 - 4085 STA		
000966	ENTERGY	265006006341	0	2023	3 INV P	3,369.52	D-122022	200429	68111178 - 8554 NOR		
000966	ENTERGY	30008409144	0	2023	3 INV P	450.62	D-122022	200429	130057649 - 7312 HI		
000966	ENTERGY	350003751509	0	2023	3 INV P	30.13	D-122022	200429	110165339 - 5730 ST		
						10,375.92					
001145	ATMOS ENERGY	1048-112222	0	2023	3 INV P	500.13	D-122022	200755	4045331048 - 7312 H		
001145	ATMOS ENERGY	4408-120122	0	2023	3 INV P	467.57	D-122022	200772	3018864408 - 8889 N		
						967.70					
018521	SOUTHERN TELECOMMUNI	11-29-2022	0	2023	3 INV P	304.85	D-122022	200775	#2480 - 6623934898/		
ACCOUNT TOTAL						11,648.47					
		ORG 902	TOTAL			11,648.47					
906	PROFESSIONAL DUES										
906	622100	PROFESSIONAL SERVICES									
036742	HOPE CENTER	11-30-22	0	2023	3 INV P	20,000.00	D-122022	200431	FY23 DONATION-BOARD		
ACCOUNT TOTAL						20,000.00					
		ORG 906	TOTAL			20,000.00					
=====											
FUND 0010 GENERAL FUND						TOTAL:	179,737.59	=====			

12/15/2022 12:58
 1540spri

 CITY OF SOUTHAVEN
 FY 2023 CLAIMS DOCKET D-122022

 P 7
 apinv gla

 YEAR/PERIOD: 2023/1 TO 2023/3
 ACCOUNT/VENDOR INVOICE

PO

YEAR/PR TYP S

WARRANT

CHECK

DESCRIPTION

ACCOUNT/VENDOR	INVOICE	PO	YEAR/PR	TYP	S	WARRANT	CHECK	DESCRIPTION
711								BOND PROJECT EXPENSES
711	640230							SNOWDEN TURF
032480	FIELDTURF USA INC	PAYAPP11	0	2023	3 INV P	177,661.98	D-122022	200762 PAY APP 11 - TURF
					ACCOUNT TOTAL	177,661.98		
					ORG 711 TOTAL	177,661.98		
=====								
	FUND 0100	BOND FUNDED CAP PROJ			TOTAL:	177,661.98		
=====								

12/15/2022 12:58
1540spri

CITY OF SOUTHAVEN
FY 2023 CLAIMS DOCKET D-122022

P 8
apinvgl

YEAR/PERIOD: 2023/1 TO 2023/3
ACCOUNT/VENDOR INVOICE

PO YEAR/PR TYP S WARRANT CHECK DESCRIPTION

YEAR/PERIOD:	2023/1	TO	2023/3						
ACCOUNT/VENDOR	INVOICE		PO	YEAR/PR	TYP	S	WARRANT	CHECK	DESCRIPTION
611				SPECIAL ASSESSMENTS EXPEND					
611	623801			NEIGHBORHOOD PARKS					
018221	CIVIL-LINK, LLC	76468	0	2023	3	INV P	6,697.99	D-122022	200428 NEIGHORHOOD PARKS,
018221	CIVIL-LINK, LLC	76469	0	2023	3	INV P	24,027.01	D-122022	200428 NEIGHBORHOOD PARKS,
018221	CIVIL-LINK, LLC	76470	0	2023	3	INV P	4,613.23	D-122022	200428 NEIGHBORHOOD PARKS,
							35,338.23		
ACCOUNT TOTAL							35,338.23		
611	623802			ARENA PARKING LOT					
018221	CIVIL-LINK, LLC	76466	0	2023	3	INV P	8,437.63	D-122022	200428 ARENA PARKING LOT E
018221	CIVIL-LINK, LLC	76467	0	2023	3	INV P	6,438.83	D-122022	200428 ARENA PARKING LOT E
							14,876.46		
ACCOUNT TOTAL							14,876.46		
			ORG 611	TOTAL			50,214.69		
=====									
FUND 0240 TOURIST & CONVENTION							TOTAL:	50,214.69	
=====									

12/15/2022 12:58
1540spri

CITY OF SOUTHAVEN
FY 2023 CLAIMS DOCKET D-122022

P 9
apinvgl

YEAR/PERIOD: 2023/1 TO 2023/3	ACCOUNT/VENDOR	INVOICE	PO	YEAR/PR TYP S	WARRANT	CHECK	DESCRIPTION
0400				UTILITY FUND			
0400	506400			WATER SALES			
	036741 FAIRLEY CATHY	11-23-22	0	2023 3 INV P	98.36	D-122022	200430 ISSUE NEW CK BECAUS
				ACCOUNT TOTAL	98.36		
0400	562500			TAP FEES-WATER			
	030515 F & F CONSTRUCTION C	12-08-22	0	2023 3 INV P	214.00	D-122022	200768 CHANCING FROM 3'MET
				ACCOUNT TOTAL	214.00		
				ORG 0400 TOTAL	312.36		
825				UTILITY MAINTENANCE EXPENSES			
825	611000			MATERIALS			
	007304 O'REILLYS AUTO PARTS	6399-131517	0	2023 3 INV P	27.47	D-122022	200435 RE-ISSUE/REMOTE BAT
				ACCOUNT TOTAL	27.47		
825	622100			PROFESSIONAL SERVICES			
	009195 GAINES, ROBERT	1262	0	2023 3 INV P	6,267.50	D-122022	200769 SCADA SERVICES
	030534 DATAFACTS	177318	0	2023 3 INV P	13.50	D-122022	200437 EMPLOYEE BACKGROUND
				ACCOUNT TOTAL	6,281.00		
825	625700			TELEPHONE & POSTAGE			
	001167 AT&T MOBILITY	7424-112722	0	2023 3 INV P	86.46	D-122022	200760 287288007424-UT SCA
				ACCOUNT TOTAL	86.46		
825	626000			UTILITIES			
	000966 ENTERGY	230005372676	0	2023 3 INV P	6,803.23	D-122022	200767 16293136- 8779 WHIT
	000966 ENTERGY	440003033206	0	2023 3 INV P	35.10	D-122022	200767 112498183-1395 PLEA
					6,838.33		
	001105 NORTHCENTRAL ELECTRI	7001-112322	0	2023 3 INV A	87.11	D-122022	59247001 - 3541 GOO
	001105 NORTHCENTRAL ELECTRI	7007-120122	0	2023 3 INV A	137.79	D-122022	59247007 - 5714 RIV
	001105 NORTHCENTRAL ELECTRI	7011-112322	0	2023 3 INV A	33.49	D-122022	59247011 - 4105 GOO
					258.39		
	001145 ATMOS ENERGY	1609-112822	0	2023 3 INV A	43.29	D-122022	4012381609 - 4164 H
	001145 ATMOS ENERGY	1654-112322	0	2023 3 INV A	22.93	D-122022	4012381654 - 53 WOO
	001145 ATMOS ENERGY	4023-120122	0	2023 3 INV A	83.00	D-122022	4009764023 - 8779 W
					149.22		
	001167 AT&T MOBILITY	8869-110322	0	2023 3 INV P	790.54	D-122022	200765 820538869- SCADA 4S



12/15/2022 12:58
1540spri

CITY OF SOUTHAVEN
FY 2023 CLAIMS DOCKET D-122022

P 10
apinvgl

YEAR/PERIOD: 2023/1 TO 2023/3	ACCOUNT/VENDOR	INVOICE	PO	YEAR/PR TYP S	WARRANT	CHECK	DESCRIPTION
				ACCOUNT TOTAL		8,036.48	
825	626900			TRAVEL & TRAINING			
001339	CREDIT CARD CENTER	12-14-22	0	2023 3 INV P	316.08 D-122022	200756	CANDENCE BANK CREDI
				ACCOUNT TOTAL		316.08	
				ORG 825 TOTAL		14,747.49	
=====							
	FUND 0400 UTILITY FUND			TOTAL:		15,059.85	
=====							

12/15/2022 12:58
1540spri

CITY OF SOUTHAVEN
FY 2023 CLAIMS DOCKET D-122022

P 11
apinv gla

YEAR/PERIOD: 2023/1 TO 2023/3	ACCOUNT/VENDOR	INVOICE	PO	YEAR/PR TYP S	WARRANT	CHECK	DESCRIPTION
0600				PAYROLL FUND			
0600	214700			GARNISHMENTS			
	021029	CHAPLAINS BENEVOLENC NOV2022-SFD	0	2023 3 INV P	274.00	D-122022	200427 NOV. 2022-FIRE DEPT
	021029	CHAPLAINS BENEVOLENC NOV2022-SPD	0	2023 3 INV P	40.00	D-122022	200426 NOV. 2022 POLICE DE
					314.00		
				ACCOUNT TOTAL	314.00		
0600	215700			MS CREDIT UNION			
	001407	MS PUBLIC EE CR UN NOV-2022	0	2023 3 INV P	5,004.42	D-122022	200433 NOV. 2022 EMPLOYEE
				ACCOUNT TOTAL	5,004.42		
0600	216106			ID THEFT/PREPD LEGAL			
	014191	PRE-PAID LEGAL SERVI 12052022	0	2023 3 INV P	2,406.90	D-122022	200774 DEC. 2022-PREPAID L
				ACCOUNT TOTAL	2,406.90		
				ORG 0600 TOTAL	7,725.32		
=====							
	FUND 0600	PAYROLL FUND		TOTAL:	7,725.32		
=====							

** END OF REPORT - Generated by Sonya Pride **



12/15/2022 12:50
1540spri

CITY OF SOUTHAVEN
FY 2023 CLAIMS DOCKET W-122022

P 1
apinv gla

YEAR/PERIOD: 2023/1 TO 2023/3	ACCOUNT/VENDOR	INVOICE	PO	YEAR/PR TYP S	WARRANT	CHECK	DESCRIPTION
0010				GENERAL FUND			
0010	211300			SALES TAX PAYABLE			
	001176 MS DEPT OF REVENUE	12-7-22	0	2023 3 DIR P	624.11 W-122022	57129	SALES TAX NOVEMBER
				ACCOUNT TOTAL	624.11		
				ORG 0010 TOTAL	624.11		
=====							
	FUND 0010	GENERAL FUND		TOTAL:	624.11		
=====							

12/15/2022 12:50
1540spri

CITY OF SOUTHAVEN
FY 2023 CLAIMS DOCKET W-122022

P 2
apinvgl

YEAR/PERIOD: 2023/1 TO 2023/3
ACCOUNT/VENDOR INVOICE

PO

YEAR/PR TYP S

WARRANT

CHECK

DESCRIPTION

ACCOUNT/VENDOR	INVOICE	PO	YEAR/PR TYP S	WARRANT	CHECK	DESCRIPTION
0400			UTILITY FUND			
0400 211300			SALES TAX PAYABLE			
001176 MS DEPT OF REVENUE	12-7-22	0	2023 3 DIR P	19,040.98 W-122022	57129	SALES TAX NOVEMBER
			ACCOUNT TOTAL	19,040.98		
			ORG 0400 TOTAL	19,040.98		
=====						
FUND 0400 UTILITY FUND				TOTAL:		19,040.98
=====						

12/15/2022 12:50
1540spri

CITY OF SOUTHAVEN
FY 2023 CLAIMS DOCKET W-122022

P 3
apinvglA

YEAR/PERIOD: 2023/1 TO 2023/3	ACCOUNT/VENDOR	INVOICE	PO	YEAR/PR TYP S	WARRANT	CHECK	DESCRIPTION
0600				PAYROLL FUND			
0600	214100			MS STATE RETIREMENT			
	002313	MS STATE RETIREMENT 12-7-2022	0	2023 3 DIR P	600,868.73	W-122022	57128 NOVEMBER 2022 PAYRO
				ACCOUNT TOTAL	600,868.73		
0600	214900			DEFERRED COMPENSATION			
	002311	EMPOWER RETIREMENT 1048048582	0	2023 3 DIR P	6,071.72	W-122022	57127 DEC. 2, 2022 PAYROL
	002311	EMPOWER RETIREMENT 1048757800	0	2023 3 DIR P	3,587.50	W-122022	57133 DEC 9 2022 PAYROLL
					9,659.22		
				ACCOUNT TOTAL	9,659.22		
0600	215101			CAF-PRETAX MEDICAL			
	022644	CORPORATE PLANNING 12-09-2022	0	2023 3 DIR P	4,665.23	W-122022	57130 DEC.09,2022 FSA/DC
	022644	CORPORATE PLANNING 12-2-2022	0	2023 3 DIR P	1,387.88	W-122022	57126 DEC. 2, 2022 FSA-FI
					6,053.11		
				ACCOUNT TOTAL	6,053.11		
0600	216100			SHORT TERM DISABILITY			
	035154	COLONIAL LIFE 57505751107101	0	2023 3 DIR P	4,344.82	W-122022	57131 NOV. 2022 EMPLOYEE
				ACCOUNT TOTAL	4,344.82		
				ORG 0600 TOTAL	620,925.88		
=====							
	FUND 0600 PAYROLL FUND			TOTAL:	620,925.88		
=====							

** END OF REPORT - Generated by Sonya Pride **

12/15/2022 12:45
1540spri

CITY OF SOUTHAVEN
FY 2023 CLAIMS DOCKET U-122022

P 1
apinvgl

YEAR/PERIOD:	2023/1	TO	2023/3							
ACCOUNT/VENDOR		INVOICE	PO	YEAR/PR	TYP	S	WARRANT	CHECK	DESCRIPTION	
0400									UTILITY FUND	
0400	130700								ACCOUNTS RECEIVABLE	
005625	KREUNEN CONST	41751	0	2023	3	INV A	29.28	U-122022		
005625	KREUNEN CONST	41752	0	2023	3	INV A	14.64	U-122022		
005625	KREUNEN CONST	41753	0	2023	3	INV A	29.28	U-122022		
005625	KREUNEN CONST	41754	0	2023	3	INV A	29.28	U-122022		
							<u>102.48</u>			
014605	WILLIAMS HEATHER	41696	0	2023	3	INV A	61.08	U-122022		
018024	COURTNEY WILLIAM B I	41787	0	2023	3	INV A	98.36	U-122022		
020777	KREUNEN KIM	41699	0	2023	3	INV A	54.44	U-122022		
021080	REGENCY HOME BUILDER	41783	0	2023	3	INV A	105.48	U-122022		
023124	JSS HOMES LLC	41722	0	2023	3	INV A	12.76	U-122022		
025122	RAY DANIEL	41771	0	2023	3	INV A	45.08	U-122022		
025277	MARATHON MANAGEMENT	41776	0	2023	3	INV A	98.36	U-122022		
025353	IMAGE HOMES RENTAL	41679	0	2023	3	INV A	125.00	U-122022		
025486	ALIZADEGAN REZA	41681	0	2023	3	INV A	45.08	U-122022		
026680	SKY LAKE CONSTRUCTIO	41737	0	2023	3	INV A	12.76	U-122022		
026680	SKY LAKE CONSTRUCTIO	41738	0	2023	3	INV A	110.36	U-122022		
026680	SKY LAKE CONSTRUCTIO	41739	0	2023	3	INV A	22.52	U-122022		
026680	SKY LAKE CONSTRUCTIO	41740	0	2023	3	INV A	81.08	U-122022		
026680	SKY LAKE CONSTRUCTIO	41763	0	2023	3	INV A	95.72	U-122022		
026680	SKY LAKE CONSTRUCTIO	41764	0	2023	3	INV A	81.08	U-122022		
026680	SKY LAKE CONSTRUCTIO	41765	0	2023	3	INV A	90.84	U-122022		
026680	SKY LAKE CONSTRUCTIO	41766	0	2023	3	INV A	95.72	U-122022		
026680	SKY LAKE CONSTRUCTIO	41767	0	2023	3	INV A	95.72	U-122022		
026680	SKY LAKE CONSTRUCTIO	41768	0	2023	3	INV A	95.72	U-122022		
026680	SKY LAKE CONSTRUCTIO	41769	0	2023	3	INV A	110.36	U-122022		
026680	SKY LAKE CONSTRUCTIO	41770	0	2023	3	INV A	95.72	U-122022		
026680	SKY LAKE CONSTRUCTIO	41784	0	2023	3	INV A	110.36	U-122022		
							<u>1,097.96</u>			
026683	PINNACLE DEVELOPMENT	41750	0	2023	3	INV A	90.84	U-122022		
029130	MAHAR TERESA	41788	0	2023	3	INV A	90.36	U-122022		
030008	ANGLIN MARK	41689	0	2023	3	INV A	98.36	U-122022		
030326	ARTIGLIBERE JOSEPH	41743	0	2023	3	INV A	18.04	U-122022		
031630	MASSEY HOMEBUILDERS	41734	0	2023	3	INV A	71.32	U-122022		

12/15/2022 12:45
1540apri

CITY OF SOUTHAVEN
FY 2023 CLAIMS DOCKET U-122022

P 2
apinvgl

YEAR/PERIOD: 2023/1 TO 2023/3										
ACCOUNT/VENDOR	INVOICE	PO	YEAR/PR	TYP	S	WARRANT	CHECK	DESCRIPTION		
034210 MYND MANAGEMENT INC	41762	0	2023 3	INV	A	98.36	U-122022			
035187 LIN JEANETTE UBOVPM	41781	0	2023 3	INV	A	45.08	U-122022			
035815 D. R. HORTON	41748	0	2023 3	INV	A	100.46	U-122022			
035815 D. R. HORTON	41749	0	2023 3	INV	A	100.46	U-122022			
035815 D. R. HORTON	41755	0	2023 3	INV	A	7.60	U-122022			
035815 D. R. HORTON	41756	0	2023 3	INV	A	127.92	U-122022			
035815 D. R. HORTON	41757	0	2023 3	INV	A	111.82	U-122022			
035815 D. R. HORTON	41758	0	2023 3	INV	A	105.34	U-122022			
035815 D. R. HORTON	41761	0	2023 3	INV	A	81.08	U-122022			
						634.68				
036560 RS RENTAL III-A, LLC	41773	0	2023 3	INV	A	66.84	U-122022			
036681 RIVER CITY LAND	41774	0	2023 3	INV	A	98.36	U-122022			
036681 RIVER CITY LAND	41779	0	2023 3	INV	A	98.36	U-122022			
						196.72				
036759 LINDA ASHBY	41678	0	2023 3	INV	A	124.60	U-122022			
036760 APG RENTALS, LLC - U	41680	0	2023 3	INV	A	71.72	U-122022			
036761 ANCHOR INVESTMENTS L	41682	0	2023 3	INV	A	125.00	U-122022			
036762 HOME INVESTMENTS LLC	41683	0	2023 3	INV	A	125.00	U-122022			
036763 HOTTY TODDY LLC - UB	41684	0	2023 3	INV	A	65.16	U-122022			
036764 ALISON SMITH PROPERT	41685	0	2023 3	INV	A	125.00	U-122022			
036765 GUELI ADAM	41686	0	2023 3	INV	A	125.00	U-122022			
036766 4 SUCCESS REALTY	41687	0	2023 3	INV	A	87.13	U-122022			
036767 ILLIG INVESTMENTS	41688	0	2023 3	INV	A	90.36	U-122022			
036768 IDEAL REALTIES	41690	0	2023 3	INV	A	125.00	U-122022			
036769 HULING RANDALL T JR	41691	0	2023 3	INV	A	20.24	U-122022			
036769 HULING RANDALL T JR	41709	0	2023 3	INV	A	7.59	U-122022			
						27.83				
036770 ALI SABA	41692	0	2023 3	INV	A	98.36	U-122022			
036770 ALI SABA	41694	0	2023 3	INV	A	50.61	U-122022			
						148.97				

12/15/2022 12:45
1540spri

CITY OF SOUTHAVEN
FY 2023 CLAIMS DOCKET U-122022

P 3
apinvgl

YEAR/PERIOD: 2023/1 TO 2023/3 ACCOUNT/VENDOR	INVOICE	PO	YEAR/PR	TYP	S	WARRANT	CHECK	DESCRIPTION
036771 LANDRY KATHERINE & F	41693	0	2023	3	INV A	10.48	U-122022	
036772 WILLIAMS MILDRED M	41695	0	2023	3	INV A	16.83	U-122022	
036773 LAMB GENE & DORLENE	41697	0	2023	3	INV A	23.36	U-122022	
036774 ANDERSON AUNDREY	41698	0	2023	3	INV A	27.36	U-122022	
036775 BOLANOS OMAR & FRANK	41700	0	2023	3	INV A	69.08	U-122022	
036776 THOMPSON JR. EDWARD	41701	0	2023	3	INV A	88.60	U-122022	
036777 WILLIAMS JARVIN	41702	0	2023	3	INV A	71.72	U-122022	
036778 CASTILLO JOSE R	41703	0	2023	3	INV A	23.36	U-122022	
036779 HODGES TIMOTHY	41704	0	2023	3	INV A	23.36	U-122022	
036780 HARPER KIM	41705	0	2023	3	INV A	98.36	U-122022	
036781 COLE ADAM	41706	0	2023	3	INV A	61.96	U-122022	
036782 HANSARD VICKEY	41707	0	2023	3	INV A	98.36	U-122022	
036783 BUCK BEBE M	41708	0	2023	3	INV A	18.48	U-122022	
036784 LEE SALLY	41710	0	2023	3	INV A	71.72	U-122022	
036785 LE FRANCIS	41711	0	2023	3	INV A	98.36	U-122022	
036786 OLIVER SHELBY	41712	0	2023	3	INV A	71.72	U-122022	
036787 WAHAB HASSAN	41713	0	2023	3	INV A	98.36	U-122022	
036788 ALHAJ KHALID	41714	0	2023	3	INV A	98.36	U-122022	
036789 CASSINO SOPHI	41715	0	2023	3	INV A	57.08	U-122022	
036790 JORDAN SIANE	41716	0	2023	3	INV A	98.36	U-122022	
036791 WRIGHT AMANDA	41717	0	2023	3	INV A	98.36	U-122022	
036792 NORMAN STATES JOSEP	41718	0	2023	3	INV A	69.08	U-122022	
036793 WATTS NATASHA	41719	0	2023	3	INV A	12.28	U-122022	
036794 PORTER JONATHAN	41720	0	2023	3	INV A	98.54	U-122022	
036795 HATCHETT TUQUINDA	41721	0	2023	3	INV A	11.67	U-122022	
036796 AYALA JUDITH	41723	0	2023	3	INV A	52.20	U-122022	

12/15/2022 12:45
1540spr1

CITY OF SOUTHAVEN
FY 2023 CLAIMS DOCKET U-122022

P 4
apinvgl

YEAR/PERIOD: 2023/1 ACCOUNT/VENDOR	TO 2023/3 INVOICE	PO	YEAR/PR	TYP	S	WARRANT	CHECK	DESCRIPTION
036797 TE INDUSTRIAL PORTFO	41724	0	2023 3	INV	A	62.61	U-122022	
036798 MOORE GERALD	41725	0	2023 3	INV	A	98.36	U-122022	
036799 THE PRO'S PAINTING C	41726	0	2023 3	INV	A	98.36	U-122022	
036800 WILSON STANLEY	41727	0	2023 3	INV	A	52.20	U-122022	
036801 HARRIS LEESA AND SEB	41728	0	2023 3	INV	A	98.36	U-122022	
036802 ALOMARI HADI	41729	0	2023 3	INV	A	71.72	U-122022	
036803 POSEY DANIEL	41730	0	2023 3	INV	A	109.00	U-122022	
036804 JAMES MICHELE	41731	0	2023 3	INV	A	52.20	U-122022	
036805 STEVENSON WILLIE	41732	0	2023 3	INV	A	45.08	U-122022	
036806 MAYS ANTONIA	41733	0	2023 3	INV	A	1.99	U-122022	
036807 PENALVER JOSE	41735	0	2023 3	INV	A	22.18	U-122022	
036808 ELLIS CAMERON	41736	0	2023 3	INV	A	45.08	U-122022	
036809 BUTLER DILLON & SARA	41741	0	2023 3	INV	A	66.84	U-122022	
036810 HUGHES JAMES	41742	0	2023 3	INV	A	48.90	U-122022	
036811 MAIN STREET RENEWAL	41744	0	2023 3	INV	A	98.36	U-122022	
036812 WINGO STEVEN	41745	0	2023 3	INV	A	98.36	U-122022	
036813 RIVER TOWN REALTY	41746	0	2023 3	INV	A	90.36	U-122022	
036814 NEWASE RAKESH SAMPAT	41747	0	2023 3	INV	A	98.36	U-122022	
036815 PIONEER HOME BULDERS	41759	0	2023 3	INV	A	98.36	U-122022	
036816 MEMPHIS INVESTMENTS	41760	0	2023 3	INV	A	71.72	U-122022	
036817 AMERICAN CASH	41772	0	2023 3	INV	A	128.66	U-122022	
036818 REEDY & COMPANY	41775	0	2023 3	INV	A	71.72	U-122022	
036819 RODMAN PROPERTIES LL	41777	0	2023 3	INV	A	98.36	U-122022	
036820 BURNS CHRIS	41778	0	2023 3	INV	A	98.36	U-122022	
036821 WILSON ANGELIA PARKS	41780	0	2023 3	INV	A	59.32	U-122022	
036822 BILL SEXTON	41782	0	2023 3	INV	A	71.72	U-122022	



12/15/2022 12:45
1540spri

CITY OF SOUTHAVEN
FY 2023 CLAIMS DOCKET U-122022

P 5
apinvgl

YEAR/PERIOD: 2023/1 TO 2023/3 ACCOUNT/VENDOR	INVOICE	PO	YEAR/PR TYP S	WARRANT	CHECK	DESCRIPTION
036823 BULLY INDUSTRIAL	41785	0	2023 3 INV A	368.69	U-122022	
036824 THE NET LLC.	41786	0	2023 3 INV A	725.00	U-122022	
ACCOUNT TOTAL				9,115.08		
ORG 0400 TOTAL				9,115.08		
=====						
FUND 0400 UTILITY FUND				TOTAL:	9,115.08	
=====						

** END OF REPORT - Generated by Sonya Pride **



The City of Southaven Docket Recap

December 20, 2022

Special Docket

General Fund		-
	Fire	-
	Ems	-
	Public Works	-
	Parks	-
	Facilities Management	-
Tourist & Convention		-
Payroll Fund		17,649.33
SPECIAL DOCKET TOTAL		17,649.33

*Note: Life Insurance Company of North America (Cigna)



12/15/2022 12:39
1540spri

CITY OF SOUTHAVEN
FY 2023 CLAIMS DOCKET S-122022

P 1
apinvgl

YEAR/PERIOD: 2023/1 TO 2023/3	ACCOUNT/VENDOR	INVOICE	PO	YEAR/PR TYP S	WARRANT	CHECK	DESCRIPTION
0600				PAYROLL FUND			
0600	216108			VOLUNTARY LIFE INSURANCE			
	022642	LIFE INSURANCE COMPA NOV22-LIFE	0	2023 3 DIR P	17,649.33	S-122022	57132 NOVEMBER 2022 EMPLO
				ACCOUNT TOTAL	17,649.33		
				ORG 0600 TOTAL	17,649.33		
=====							
	FUND 0600	PAYROLL FUND		TOTAL:	17,649.33		
=====							

** END OF REPORT - Generated by Sonya Pride **

5.
Approval of Travel
for
MML and DC Congressional
Briefing Trip

Purchase Agreement

Customer Purchase Order

Billing Location

Install Location

Full Customer Name – Include Inc., Corp., LLC etc.
City Of Southaven

Customer Name
City Of Southaven

Department _____ County _____

Street Address
8691 Northwest Dr

Street Address
8691 Northwest Dr

City Southaven State MS Zip+4 38671

City Southaven State MS Zip+4 38671

Contact Name Lisa Cunningham Phone # 662-280-6557 Fax # _____

Meter Contact Lisa Cunningham Phone # 662-280-6557 Fax # _____

Email _____

Email _____

Qty.	Manufacturer	Equip. ID	Model	Serial Number	Unit Price	Amount
1	Troy		M610 Micr printer			2274.35
1	Troy		Paper Tray			319.00

Trade-In/Buyout (Items to be picked up)					Total This Page	2593.35
					Total From Add'l Equipment List	0.00
					Sales Tax	
					Tax Exempt <input type="checkbox"/> Yes <input type="checkbox"/> No Attach Exemption Certificate	Total 2593.35

1) The equipment specified above will be provided at the following rates:

Commencement Date	SMP/Maintenance none	Total Minimum Payment	Minimum Billing Frequency Monthly	Overage Billing Frequency Monthly
Monthly Minimum Number of B&W Copies 0	Overage Rate per B&W Copy 0.043600	Monthly Minimum Number of Color Copies	Overage Rate per Color Copy	Agreement Includes <input type="checkbox"/> Yes <input type="checkbox"/> No Master Unit <input type="checkbox"/> Yes <input type="checkbox"/> No Color Supplies <input type="checkbox"/> Yes <input type="checkbox"/> No Drum/Photo Conductor <input type="checkbox"/> Yes <input type="checkbox"/> No Imaging Units <input type="checkbox"/> Yes <input type="checkbox"/> No Parts/Labor <input type="checkbox"/> Yes <input type="checkbox"/> No Toner/Dispersant <input type="checkbox"/> Yes <input type="checkbox"/> No Developer <input type="checkbox"/> Yes <input type="checkbox"/> No Other <input type="checkbox"/> New Account <input type="checkbox"/> New Equipment <input type="checkbox"/> Upgrade <input type="checkbox"/> Remanufactured Equipment <input type="checkbox"/> Additional Unit <input type="checkbox"/> Used <input type="checkbox"/> MAM <input type="checkbox"/> MAM <input type="checkbox"/> Yes <input type="checkbox"/> No MICR Toner
Monthly Minimum Number of Square Feet	Overage Rate per Square Foot	Monthly Minimum Number of Linear Feet	Overage Rate per Linear Foot	
Monthly Minimum Number of B&W Prints	Overage Rate per B&W Print	Monthly Minimum Number of Color Prints	Overage Rate per Color Print	
Monthly Minimum Number of Misc	Overage Rate per Misc	Monthly Minimum Number of Misc 2	Overage Rate per Misc 2	

Remarks:

Additional terms and conditions on page 2.		Sales Rep: _____ Date: _____	
Signature: _____ Print Name: _____ Title: _____ Date: _____		Sales Manager: _____ Date: _____	

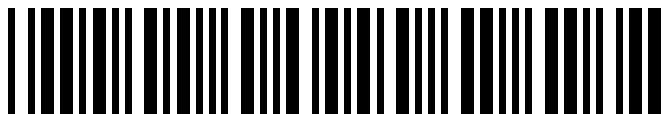

2. The title to any and all products listed on the Sales Order remain with RJ Young Company (RJY) until full payment is received from you. Invoices are payable upon receipt unless prior written approval is received from the RJY corporate offices.
3. Without prior written approval of RJY you may not assign any of your rights or obligations under this Agreement or allow a lien or encumbrance of any kind to be placed upon any products for which you have not received title free and clear.
4. If payment is not paid when due, you will pay us a late charge of up to 15% of the amount of the payment or \$15.00 whichever is greater (or such lesser rate as is maximum rate allowed under applicable law). You also agree to pay \$35.00 for each returned check. Restrictive endorsements or additional terms on checks you send to us will not reduce your obligations to us.
5. If payment is not paid when due, we will have the right to take ONE OR MORE of the following actions, in addition to any and all other remedies that may be available to us under the law: (a) cancel this agreement without prior notice or warning to you; (b) file a law suit against you to collect all past due amounts, plus all our reasonable legal costs, including but not limited to reasonable attorneys' fees, reasonable overhead for employee time spent on preparing for suit or attempting to collect payments and mitigate our damages; (c) repossess the Equipment or apply to a court for an order allowing repossession for any Equipment for which you have not received title free and clear.
6. This Agreement, and other terms and conditions that you have acknowledged receipt of by signing this Sales Order, constitute the entire Agreement.
7. As a convenience to you and to further expedite this transaction for you, you agree that a photocopy, electronic image or facsimile of this Agreement which includes a photocopy, electronic image or facsimile of the signatures of both parties shall be as valid, authentic and legally binding as the original version for all purposes and shall be admissible in court as final and conclusive evidence of this transaction and of the execution of this document.

SMP AND/OR MAINTENANCE AGREEMENT

The following terms and conditions are in addition to the General Terms and Conditions above.

8. Service includes both labor and material for adjustments, repairs and replacement of parts as necessitated by normal equipment usage. Also included are regularly scheduled preventive maintenance and emergency service subject to provisions. The charge is based on the original geographic installation location of the machine and RJY must be notified whenever the geographical location of the equipment is changed. If the equipment has been moved to a new RJY service zone, a new agreement must be reached. For efficient and electronic meter reading, RJY utilizes specialized software that reports current meter readings on all print devices connected to your Network. Customer agrees that meters may be accessed and reported in this manner. Should the number of scans exceed the total of all prints and copies, we reserve the right to invoice these excess scans at \$.0025 per scan. This agreement does not cover overhauls on the machine.
9. Service calls will be made during normal business hours at the specified installation address. (Business hours are 8:00 a.m. to 5:00 p.m., Monday to Friday). Travel and labor time on calls made other than during normal business hours will be charged to Customer at established overtime rates.
10. Meter cards or fax forms will be provided to the Customer for monthly or quarterly billings. If forms are not received by the required date, an estimated meter will be used for billing purposes.
11. Customer agrees to make available a Meter Contact for training purposes in the use of the equipment and agrees to notify RJY of any change in the Meter Contact assignment.
12. Service will not be provided on equipment upon which there has been used unauthorized parts or supplies or that has been modified or used by unauthorized personnel to repair or change said equipment. Master or drums will not be replaced under this agreement when damage is caused by operator abuse or error. An initial master or drum charge may be required on older equipment.
13. This agreement shall be effective on the date of delivery of equipment if new equipment, otherwise on the commencement date listed on the contract and shall continue for a period of 12 months from the date and will automatically renew for consecutive 12 month periods unless written cancellation notice is given by either party 30 days prior to the end of the then current term. In the event of cancellation of this agreement for any reason, unused supplies shall be the property of RJY, although Customer may purchase the supplies at the then prevailing retail rates. Customer agrees to pay the periodic charges and upon failure to do so RJY may (1) terminate the agreement, (2) refuse to service the equipment or furnish supplies, (3) recover damages as a result thereof. City will be notified before any increase.
14. At the end of each contract anniversary date, ~~the rate charge can increase without written notice to allow for cost increases.~~
15. This agreement is not refundable or transferrable to a third party. If the equipment is traded in on new equipment, any unused portion of the contract period charge shall be prorated and credited to the Customer.
16. This agreement may not be assigned by Customer without the written consent of RJY. This instrument contains the entire agreement between the parties and cannot be altered or amended except by an instrument in writing signed by the parties hereto. Any agreement containing variations from the printed terms set forth herein must be accepted and counter-signed by an officer of RJY at its offices in Nashville, Tennessee.
17. Sales or use tax shall be added where applicable.

RESOLUTION OF THE MAYOR AND BOARD OF ALDERMEN OF THE CITY OF SOUTHAVEN, MISSISSIPPI AMENDING THE CITY OF SOUTHAVEN UTILITIES RATE

WHEREAS, pursuant to Section 21-17-5(1) of the Mississippi Code (1972) the Mayor and Board of Aldermen have the power to adopt any orders, resolutions or ordinances with respect to municipal affairs, property and finances which are not inconsistent with the Mississippi Constitution of 1890, the Mississippi Code of 1972 or any other statute or law of the State of Mississippi; and

WHEREAS, the City of Southaven (“City”) is vested with the authority to operate a waterworks system and establish rates, including rate increases, at which the water will be supplied to municipal utility customers in accordance with Mississippi Code Annotated Section 21-27-7; and

WHEREAS, the Mayor and Board of Aldermen of the City has been granted the authority to create, maintain and operate public utility systems within the City, and in certain areas outside the City, pursuant to Section 21-27-23 of the Mississippi Code (1972); and

WHEREAS, in accordance with Mississippi law, the City has established water and sewer systems, and

WHEREAS, due to the increase costs for treatment imposed to the City by the Horn Lake Creek Basin Interceptor Sewer District, the City Governing Authorities need to increase the utility rate charged by the City; and

WHEREAS, the City is not increasing rates on customers residing in an area that is greater than one mile outside of the City boundaries; and

WHEREAS, the City rate increase is not being done to create surplus revenues and the increased rate is reasonably calculated to provide for the system's functioning and growth; and

WHEREAS, the City has considered the potential function and increased costs of the system so that the increase of the utility rate will result in a generation of revenues that are just and reasonable, and not excessive, which will support operation of the system; and

NOW, THEREFORE, BE IT RESOLVED by the Mayor and Board of Aldermen of the City of Southaven, Mississippi as follows:

1. The City of Southaven sewer rate shall increase as follows:

Residential

Water - \$2.89 per unit

Sewer - \$2.96 per unit

Commercial

Water - \$3.85 per unit

Sewer - \$4.44 per unit

2. There shall be minimum monthly charge of \$17.57 for each residential customer who has access to the City of Southaven sewer system.

3. The Mayor, City Utility Director or their designee(s) are authorized to take all actions to effectuate the intent of this Resolution.

Following a reading of the foregoing resolution, Aldermen _____ made the motion and Alderman _____ seconded the motion for its adoption. The Mayor put the question to a roll call vote and the result was as follows:

Alderman William Jerome voted:

Alderman Kristian Kelly voted:

Alderman George Payne voted:

Alderman Joel Gallagher voted:

Alderman John Wheeler voted:

Alderman Raymond Flores voted:

Alderman Charlie Hoots voted:

RESOLVED AND DONE, this 3rd day of January, 2023.

DARREN L. MUSSELWHITE, MAYOR

ATTEST:

CITY CLERK

8.

Planning Agenda

9.
Mayor's Report

Personnel Docket

January 3, 2023

New Hires	Department	Position Title	Start Date	Rate of Pay
Lee Starks	Police	Crossing Guard	1/5/2023	\$12.88
Keilah Weathersby	Fire	Paramedic	TBD	\$21.22

Promotions	Current Position Title	New Position Title	Effective Date	Rate of Pay
<i>Utilities</i> Donnie Young	Field Service Tech	Foreman	1/2/2023	\$21.51

Resignations/Terminations	Department	Current Position Title	Effective Date	Rate of Pay
Austin Gayhart	Fire	EMS Driver	12/22/2022	\$17.15
Markquiuna Henry	Police	Crossing Guard	12/13/2022	\$12.88
Haaken Thompson	Utilities	Foreman	12/30/2022	\$22.00

11.

City Attorney's
Legal Update

DEMOLITION PERMIT APPLICATION
CITY OF SOUTHAVEN
8710 NORTHWEST DRIVE
SOUTHAVEN MS 38671
PH. (662)-393-4639 FAX (662)-280-6534

SITE ADDRESS _____

OWNER OF BUILDING _____

OWNER ADDRESS _____ PHONE # _____

OWNER EMAIL _____

CONTRACTOR _____ PHONE # _____

CONTRACTOR ADDRESS _____

CONTRACTOR EMAIL _____

DATE _____ APPLICANT SIGNATURE _____

APPLICATION FEE

RESIDENTIAL	\$375.00	_____
COMMERICAL	\$750.00	_____
	TOTAL	_____

The demolition of any structure must be completed within thirty days from the date of issue of permit. Inspections as required by the Building Inspector and Fire Marshall shall be coordinated by the permit holder. Final inspection shall be made upon completion of all required demolition work. Debris and materials resulting from demolition shall be removed from the premises and said demolition shall be done in such a manner as not to create a nuisance or unsafe conditions to the surrounding area.

Demolition of any structure includes removing the foundation or slab and proper disconnection of any utilities on the site. The entire site must be returned to a non-developed status. It must include vegetation to reduce erosion and adverse effects to storm water systems.

Revised 12/21/22

DATE _____ APPLICANT SIGNATURE _____



The City of Southaven Docket Recap January 3, 2023

General Fund	361,227.86
Balance Sheet	-
Mayor Admin	2,736.44
Board of Aldermen	-
Arts And Cultural Affairs	1,793.14
Court	2,936.01
Finance & Administration	152.04
Information Technology	1,392.54
City Clerk	1,390.85
Operations Department	6,873.69
Planning & Engineering	3,374.79
Emergency Services	5,549.95
Police	151,689.55
Fire	29,872.82
Fire Prevention	9.99
EMS	11,166.18
Public Works	50,901.25
Streets	-
Parks	65,968.92
Park Tournaments	17,278.09
Code Enforcement	586.39
City Fuel	-
Expense Accounts	6,655.22
Administrative Expenses	900.00
Litigation	-
Liability Insurance	-
Professional Dues	-
Bond Funded CAP Proj	-
Tourist & Convention	-
Debt Service	-
Utility Fund	757,302.00
Sanitation Fund	52.40
Payroll Fund	615,411.27
DOCKET TOTAL	1,733,993.53



12/29/2022 12:52
1540spri

CITY OF SOUTHAVEN
FY 2023 CLAIMS DOCKET C-010323

P 1
apinvgl

YEAR/PERIOD: 2023/1 TO 2023/4
ACCOUNT/VENDOR INVOICE

PO

YEAR/PR TYP S

WARRANT

CHECK

DESCRIPTION

YEAR/PERIOD: 2023/1 TO 2023/4	ACCOUNT/VENDOR	INVOICE	PO	YEAR/PR TYP S	WARRANT	CHECK	DESCRIPTION
111				MAYOR ADMIN DEPARTMENT			
111	610400			OFFICE SUPPLIES			
	022719 UMB CARD SERVICES	1-2023-0044	0	2023 3 INV A	51.94	C-010323	PURCHASE CARD -0044
				ACCOUNT TOTAL	51.94		
111	622100			PROFESSIONAL SERVICES			
	007507 DESOTO COUNTY ECONOM	7642	0	2023 3 INV A	25.00	C-010323	QUARTERLY LUNCHEON
				ACCOUNT TOTAL	25.00		
111	626900			TRAVEL & TRAINING			
	015274 PAYNE GEORGE	10-20-2022	0	2023 3 INV A	420.25	C-010323	2023 MML WINTER CON
	020343 GALLAGHER JOEL	10-20-2022	0	2023 3 INV A	420.25	C-010323	2023 MML WINTER CON
	020345 FLORES RAYMOND	10-20-2022	0	2023 3 INV A	420.25	C-010323	2023 MML WINDTER CO
	026786 WHEELER JOHN DAVID	10-20-2022	0	2023 3 INV A	420.25	C-010323	2023 MML WINTER CON
	028582 HOOTS CHARLIE	10-20-2022	0	2023 3 INV A	420.25	C-010323	2023 MML WINTER CON
	034066 JEROME WILLIAM	10-20-2022	0	2023 3 INV A	420.25	C-010323	2023 MML WINTER CON
				ACCOUNT TOTAL	2,521.50		
				ORG 111 TOTAL	2,598.44		
120				ARTS AND CULTURAL AFFAIRS			
120	622100			PROFESSIONAL FEES			
	001361 SAM'S CLUB DIRECT	1-8-23	0	2023 3 INV A	68.14	C-010323	SAM'S CLUB DIRECT 1
	004489 JOHNSON CINDY	246-22	0	2023 3 INV A	540.00	C-010323	AEROBICS CLASS (DEC
	015915 WISEMAN CYNTHIA	1215-22	0	2023 3 INV A	225.00	C-010323	AEROBIC'S INST./NOV
	017272 PERKINS WENDY	1208-22	0	2023 3 INV A	210.00	C-010323	AEROBIC'S (NOV. 29
	018134 FORRESTER SHERRY	585-22	0	2023 3 INV A	630.00	C-010323	ART INST. (NOV. 6,
	021019 CAIN LINDA A	121-22	0	2023 3 INV A	60.00	C-010323	LINE DANCE CLASS (3
	021019 CAIN LINDA A	219-22	0	2023 3 INV A	60.00	C-010323	LINE DANCE (3HRS -
					120.00		
				ACCOUNT TOTAL	1,793.14		
				ORG 120 TOTAL	1,793.14		
125				COURT DEPARTMENT			
125	621500			COURT BOND REFUND			
	036827 ELIAS MANUEL	12-14-2022	0	2023 3 INV A	250.00	C-010323	CASH BOND REFUND



12/29/2022 12:52
1540spri

CITY OF SOUTHAVEN
FY 2023 CLAIMS DOCKET C-010323

P 2
apinvgl

YEAR/PERIOD: 2023/1 ACCOUNT/VENDOR	TO 2023/4 INVOICE	PO	YEAR/PR TYP S	WARRANT	CHECK	DESCRIPTION
036828 MOSES WILLIE	12-14-2022	0	2023 3 INV A	150.00 C-010323		CASH BOND REFUND
036829 WRIGHT KELVIN	12-14-2022	0	2023 3 INV A	250.00 C-010323		CASH BOND REFUND
036830 WICKMAN LAURA E	12-14-2022	0	2023 3 INV A	700.00 C-010323		CASH BOND REFUND
036831 BARNES MARKEIA A	12-14-2022	0	2023 3 INV A	350.00 C-010323		CASH BOND REFUND
036832 HARRIS KEYSHAWN	12-15-2022	0	2023 3 INV A	125.00 C-010323		CASH BOND REFUND
036835 NIXON NYKIAYA D	12-21-2022	0	2023 3 INV A	150.00 C-010323		CASH BOND REFUND
ACCOUNT TOTAL				1,975.00		
125 621501			COURT FINES			
024253 AMERICAN MUNICIPAL S 55603		0	2023 3 INV A	53.30 C-010323		NOVEMBER 2022 COLLE
ACCOUNT TOTAL				53.30		
125 621505			COURT SUPPLIES			
007600 ODP BUSINESS	280214338001	0	2023 3 INV A	87.76 C-010323		FILE FOLDERS /PENS
007600 ODP BUSINESS	280216103001	0	2023 3 INV A	12.64 C-010323		PENS
				100.40		
022719 UMB CARD SERVICES	1-2023-0044	0	2023 3 INV A	85.80 C-010323		PURCHASE CARD -0044
030629 AMAZON CAPITAL	16KQXTX41YVV	0	2023 3 INV A	18.49 C-010323		METAL ICE SCOOP
ACCOUNT TOTAL				204.69		
125 622100			PROFESSIONAL SERVICES			
020605 STOCKTON KENNETH	12-14-2022	0	2023 3 INV A	200.00 C-010323		SPECIAL PROSECUTOR
ACCOUNT TOTAL				200.00		
ORG 125 TOTAL				2,432.99		
150			INFORMATION TECHNOLOGY			
150 610500			COMPUTERS			
000739 CDW LLC	FQ22057	0	2023 3 INV A	27.28 C-010323		CRADLEPOINT ANTENNA
007600 ODP BUSINESS	276837133001	0	2023 3 INV A	308.13 C-010323		TONER CARTRIDGE 4TH
007600 ODP BUSINESS	281675298001	0	2023 3 INV A	63.16 C-010323		IT SUPPLIES
				371.29		
026785 BEST BUY	6716321	0	2023 3 INV A	9.49 C-010323		BATTERY -GREENBROOK
029120 YOUNG LEASING CO	INV6058772	0	2023 3 INV A	55.90 C-010323		#AAA104054 - COPY C
029120 YOUNG LEASING CO	INV6081836	0	2023 3 INV A	4.55 C-010323		AAA104054- IT COPY



12/29/2022 12:52
1540spri

CITY OF SOUTHAVEN
FY 2023 CLAIMS DOCKET C-010323

P 4
apinvgl

YEAR/PERIOD: 2023/1 TO 2023/4	ACCOUNT/VENDOR	INVOICE	PO	YEAR/PR	TYP	S	WARRANT	CHECK	DESCRIPTION
									1,098.27
	005044	LOWE'S HOME CENTERS, 1-15-23	0	2023	3	INV A	213.64	C-010323	896 0 -LOWE'S CREDI
	007304	O'REILLYS AUTO PARTS 1257-214668	0	2023	3	INV A	136.45	C-010323	ARENA GENERATOR BAT
	007600	ODP BUSINESS 280902882001	0	2023	3	INV A	80.70	C-010323	JANITORAL SUPPLY TR
	011401	LIGHT BULB DEPOT, LL 21688523	0	2023	3	INV A	157.50	C-010323	ARCHIVE AREA DISPLA
	011790	MAGNOLIA LIGHTING, I 362130	0	2023	3	INV A	111.84	C-010323	MATERIALS
	028212	UNITED REFRIGERATION 88086272	0	2023	3	INV A	26.83	C-010323	MATERIALS
	028212	UNITED REFRIGERATION 88092099	0	2023	3	INV A	564.86	C-010323	SNOWDEN HOUSE SWITC
	028212	UNITED REFRIGERATION 88164969	0	2023	3	INV A	40.29	C-010323	MATERIALS
									631.98
						ACCOUNT TOTAL			2,538.69
160	622100					PROFESSIONAL SERVICES			
	000232	MATHESON & ASSOC LLC 22488	0	2023	3	INV A	1,610.00	C-010323	COURT DEPT ANNUAL F
	000232	MATHESON & ASSOC LLC 22492	0	2023	3	INV A	1,510.00	C-010323	TENNIS CENTER ANNUA
									3,120.00
	033109	MID-SOUTH EMERGENCY 4890	0	2023	3	INV A	630.00	C-010323	CITY HALL E.M LIGHT
	035717	NICHOLS FIRE 80831	0	2023	3	INV A	575.00	C-010323	1/4 ANNUAL CODE BLU
						ACCOUNT TOTAL			4,325.00
						ORG 160 TOTAL			6,863.69
180	610400					PLANNING / ENGINEERING DEPT OFFICE SUPPLIES			
	022719	UMB CARD SERVICES 1-2023-0044	0	2023	3	INV A	269.99	C-010323	PURCHASE CARD -0044
						ACCOUNT TOTAL			269.99
180	611300					MOTOR VEH REPAIRS/MAINT			
	005609	A&B FAST AUTO GLASS 1062208	0	2023	3	INV A	375.00	C-010323	VEHICLE MAINTENANCE
						ACCOUNT TOTAL			375.00
180	622100					PROFESSIONAL FEES			
	025688	ROSE JUNE 12-22-22	0	2023	3	INV A	100.00	C-010323	PLANNING COMMISSION
	025693	BREWER WILLIAM JOSEP 12-22-22	0	2023	3	INV A	100.00	C-010323	PLANNING COMMISSION
	025694	CAMP JOHN 12-22-22	0	2023	3	INV A	100.00	C-010323	PLANNING COMMISSION



12/29/2022 12:52
1540spri

CITY OF SOUTHAVEN
FY 2023 CLAIMS DOCKET C-010323

P 5
apinv gla

YEAR/PERIOD: 2023/1 ACCOUNT/VENDOR	TO 2023/4 INVOICE	PO	YEAR/PR TYP S	WARRANT	CHECK	DESCRIPTION
027031 LEEKE KEVIN	12-22-22	0	2023 3 INV A	100.00 C-010323		PLANNING COMMISSION
029239 UPCHURCH DINK	12-19-2022	0	2023 3 INV A	100.00 C-010323		PLANNING COMMISSION
032389 MOORE BEN A	12-22-22	0	2023 3 INV A	100.00 C-010323		PLANNING COMMISSION
			ACCOUNT TOTAL	600.00		
180 626900			TRAVEL & TRAINING			
001339 CREDIT CARD CENTER	1-13-23	0	2023 3 INV A	439.89 C-010323		TRAVEL CARD-1/13/23
022633 NWMCEA	12-14-2022	0	2023 3 INV A	500.00 C-010323		2023 MEMBER. APP:SH
			ACCOUNT TOTAL	939.89		
			ORG 180 TOTAL	2,184.88		
211			POLICE DEPARTMENT			
211 610100			CLEANING SUPPLIES			
007823 AMERICAN PAPER & TWI	4513566	0	2023 3 INV A	227.52 C-010323		KITCHEN TOWELS W. P
			ACCOUNT TOTAL	227.52		
211 610400			OFFICE SUPPLIES			
007600 ODP BUSINESS	277367302001	0	2023 3 INV A	349.95 C-010323		FLASH DRIVES ISU
007600 ODP BUSINESS	281170490001	0	2023 3 INV A	168.13 C-010323		OFFICE SUPPLIES
				518.08		
030629 AMAZON CAPITAL	1YL7T1M43XKT	0	2023 3 INV A	42.68 C-010323		EVIDENCE
			ACCOUNT TOTAL	560.76		
211 611000			MATERIALS			
000544 PRECISION DELTA CORP	23902	0	2023 3 INV A	191.85 C-010323		2022 FY ANNON ORDER
020832 EMERGENCY EQUIPMENT	477328	0	2023 3 INV A	784.00 C-010323		16 SLINGS
			ACCOUNT TOTAL	975.85		
211 611300			MAINTENANCE VEHICLES			
000883 AMERICAN TIRE REPAIR	163126	0	2023 3 INV A	2,108.32 C-010323		16 TIRES
000887 JIMMY GRAY CHEVROLET	PCP-701078	0	2023 3 INV A	222.24 C-010323		SHOP PARTS - SENSOR
001102 SOUTHAVEN SUPPLY	164127	0	2023 3 INV A	46.14 C-010323		SHOP SUPPLIES - PAI
001114 UNION AUTO PARTS	2473583	0	2023 3 INV A	521.92 C-010323		3177 BRAKES
001114 UNION AUTO PARTS	2473600	0	2023 3 INV A	34.12 C-010323		SHOP PARTS - AIR FI
001114 UNION AUTO PARTS	2476064	0	2023 3 INV A	107.73 C-010323		3219 BRAKES
001114 UNION AUTO PARTS	2476069	0	2023 3 INV A	687.14 C-010323		3145 - SENSOR



12/29/2022 12:52
1540spri

CITY OF SOUTHAVEN
FY 2023 CLAIMS DOCKET C-010323

P 6
apinvgl

YEAR/PERIOD: 2023/1 TO 2023/4
ACCOUNT/VENDOR INVOICE

PO

YEAR/PR TYP S

WARRANT

CHECK

DESCRIPTION

001114	UNION AUTO PARTS	2476140	0	2023	3	INV A	687.14	C-010323	3136 SENSOR
001114	UNION AUTO PARTS	2479384	0	2023	3	INV A	136.11	C-010323	3234 PARTS
001114	UNION AUTO PARTS	2479808	0	2023	3	INV A	59.90	C-010323	3186 PARTS
001114	UNION AUTO PARTS	2483351	0	2023	3	INV A	694.54	C-010323	4196 PUMP
001114	UNION AUTO PARTS	2484088	0	2023	3	INV A	118.18	C-010323	3234 - PARTS
001114	UNION AUTO PARTS	2484125	0	2023	3	CRM A	-136.11	C-010323	CREDIT - SHOP PARTS
001114	UNION AUTO PARTS	2486432	0	2023	3	INV A	9.71	C-010323	SHOP PARTS
001114	UNION AUTO PARTS	2487958	0	2023	3	INV A	470.61	C-010323	3051 PARTS
001114	UNION AUTO PARTS	2488015	0	2023	3	INV A	9.60	C-010323	SHOP PARTS
001114	UNION AUTO PARTS	2490015	0	2023	3	INV A	47.76	C-010323	SHOP PARTS
001114	UNION AUTO PARTS	2490027	0	2023	3	CRM A	-100.00	C-010323	CREDIT BATTERY CORE
001114	UNION AUTO PARTS	2490698	0	2023	3	INV A	35.26	C-010323	SHOP PARTS

3,383.61

001150	NAPA GENUINE PARTS C	847327	0	2023	3	INV A	118.15	C-010323	SHOP PARTS - AIR HA
001150	NAPA GENUINE PARTS C	847618	0	2023	3	INV A	10.91	C-010323	4191 RELAY
001150	NAPA GENUINE PARTS C	847641	0	2023	3	INV A	30.46	C-010323	SHOP PARTS - ANTIFR
001150	NAPA GENUINE PARTS C	847671	0	2023	3	INV A	121.06	C-010323	VAN PARTS
001150	NAPA GENUINE PARTS C	847710	0	2023	3	INV A	8.06	C-010323	1333 CABLE
001150	NAPA GENUINE PARTS C	847718	0	2023	3	INV A	81.83	C-010323	1333 PARTS
001150	NAPA GENUINE PARTS C	847798	0	2023	3	INV A	309.04	C-010323	3113 PARTS

679.51

005044	LOWE'S HOME CENTERS, 1-15-23		0	2023	3	INV A	139.20	C-010323	896 0 -LOWE'S CREDI
005407	NORTH MS. TWO-WAY CO 48574		0	2023	3	INV A	99.25	C-010323	4194 REPAIRS
006706	LANDERS DODGE	397773	0	2023	3	INV A	1,352.25	C-010323	3177 PARTS
006706	LANDERS DODGE	397922	0	2023	3	INV A	322.50	C-010323	3177 WIRING
006706	LANDERS DODGE	398057	0	2023	3	INV A	391.50	C-010323	3213 STARTER
006706	LANDERS DODGE	398235	0	2023	3	INV A	179.76	C-010323	SHOP PARTS
006706	LANDERS DODGE	398555	0	2023	3	INV A	382.50	C-010323	SHOP PARTS - SOLENO
006706	LANDERS DODGE	398617	0	2023	3	INV A	198.00	C-010323	3203 PARTS - CYLIND

2,826.51

007304	O'REILLYS AUTO PARTS	1257-211756	0	2023	3	INV A	95.49	C-010323	3148 PARTS/CAPSULE
007304	O'REILLYS AUTO PARTS	1257-211931	0	2023	3	INV A	61.98	C-010323	SHOP PARTS - LOCKS
007304	O'REILLYS AUTO PARTS	1257-212060	0	2023	3	INV A	19.54	C-010323	SHOP PARTS - 40 PC
007304	O'REILLYS AUTO PARTS	1257-214853	0	2023	3	INV A	65.94	C-010323	3179,3178 MOTOR OIL
007304	O'REILLYS AUTO PARTS	1257-214971	0	2023	3	INV A	51.58	C-010323	3143 PARTS
007304	O'REILLYS AUTO PARTS	6399-134909	0	2023	3	INV A	87.98	C-010323	3094 PARTS
007304	O'REILLYS AUTO PARTS	6399-135116	0	2023	3	INV A	33.79	C-010323	SHOP PARTS - FUEL F
007304	O'REILLYS AUTO PARTS	6399-136235	0	2023	3	INV A	15.00	C-010323	3138 FILTER

431.30

011610	SOUTHERN THUNDER	199503	0	2023	3	INV A	494.81	C-010323	MOTORS PARTS
019700	CHOICE TOWING	75271	0	2023	3	INV A	50.00	C-010323	3161 TOW



12/29/2022 12:52
1540spri

CITY OF SOUTHAVEN
FY 2023 CLAIMS DOCKET C-010323

P 7
apinvgl

YEAR/PERIOD: 2023/1 TO 2023/4	ACCOUNT/VENDOR	INVOICE	PO	YEAR/PR	TYP	S	WARRANT	CHECK	DESCRIPTION
	019700 CHOICE TOWING	75277	0	2023	3	INV A	50.00	C-010323	3194 TOW
							100.00		
	029563 LANDERS FORD SOUTH	228901	0	2023	3	INV A	358.49	C-010323	3162 PARTS
	029563 LANDERS FORD SOUTH	228943	0	2023	3	INV A	35.52	C-010323	3136 GASKET
	029563 LANDERS FORD SOUTH	228966	0	2023	3	INV A	1,391.99	C-010323	3136 EXHAUST
							1,786.00		
	030773 KARZON CAR CARE LLC	7505	0	2023	3	INV A	180.00	C-010323	3146 PARTS
	030773 KARZON CAR CARE LLC	7533	0	2023	3	INV A	177.40	C-010323	3186 ALIGNMENT
	030773 KARZON CAR CARE LLC	7548	0	2023	3	INV A	1,498.25	C-010323	4196 PUMP
							1,855.65		
	032616 TC AUTO SALES	1201622	23000141	2023	3	INV A	3,650.00	C-010323	VEHICLE REPAIRS FOR
	032616 TC AUTO SALES	121622	23000142	2023	3	INV A	3,350.00	C-010323	VEHICLE REPAIRS FOR
							7,000.00		
							21,172.54		
							ACCOUNT TOTAL		
211	612500								
	000424 A 2 Z ADVERTISING	64421	0	2023	3	INV A	2,326.00	C-010323	UNIFORMS SWAT
	020832 EMERGENCY EQUIPMENT	47731	0	2023	3	INV A	89.00	C-010323	SCALLON PANTS
	020832 EMERGENCY EQUIPMENT	477327	0	2023	3	INV A	384.00	C-010323	YORK BELT GRIP
	020832 EMERGENCY EQUIPMENT	477329	0	2023	3	INV A	112.00	C-010323	ZACHARY GREENBAUM -
	020832 EMERGENCY EQUIPMENT	477727	0	2023	3	INV A	769.00	C-010323	ALLRED NEW HIRE
	020832 EMERGENCY EQUIPMENT	477728	0	2023	3	INV A	820.00	C-010323	GREGORY NEW-HIRE
	020832 EMERGENCY EQUIPMENT	477729	23000081	2023	3	INV A	955.00	C-010323	SWAT UNIFORMS FOR T
	020832 EMERGENCY EQUIPMENT	477730	0	2023	3	INV A	250.00	C-010323	LONG EQUIPMENT
	020832 EMERGENCY EQUIPMENT	477733	0	2023	3	INV A	667.00	C-010323	BRYANT NEW-HIRE
	020832 EMERGENCY EQUIPMENT	477734	0	2023	3	INV A	543.00	C-010323	PERRY NEW HIRE
	020832 EMERGENCY EQUIPMENT	477735	0	2023	3	INV A	233.00	C-010323	NASH NEW HIRE
							4,822.00		
	021916 MIDSOUTH SOLUTIONS	193493	23000086	2023	3	INV A	600.00	C-010323	IVERSON, JEREMY UNI
	021916 MIDSOUTH SOLUTIONS	193516	0	2023	3	INV A	732.00	C-010323	GREGORY, JOHN NEW-H
	021916 MIDSOUTH SOLUTIONS	193517	23000003	2023	3	INV A	496.97	C-010323	WHITEAKER, DUSTIN U
	021916 MIDSOUTH SOLUTIONS	193518	7	2023	3	INV A	471.50	C-010323	MCCLAIN, CHARLES UN
	021916 MIDSOUTH SOLUTIONS	193519	23000067	2023	3	INV A	600.00	C-010323	PRESSGROVE, MICHAEL
	021916 MIDSOUTH SOLUTIONS	193520	23000012	2023	3	INV A	500.00	C-010323	KERWIN, BRIAN UNIFO
	021916 MIDSOUTH SOLUTIONS	193548	0	2023	3	INV A	916.99	C-010323	GEESLIN NEW-HIRE
	021916 MIDSOUTH SOLUTIONS	193567	6	2023	3	INV A	491.34	C-010323	RAYBURN, LARRY UNIF
							4,808.80		
							ACCOUNT TOTAL		
							11,956.80		



12/29/2022 12:52
1540spri

CITY OF SOUTHAVEN
FY 2023 CLAIMS DOCKET C-010323

P 8
apinvgl

YEAR/PERIOD: 2023/1 TO 2023/4										
ACCOUNT/VENDOR	INVOICE	PO	YEAR/PR	TYP	S	WARRANT	CHECK	DESCRIPTION		
211	614000							FUEL & OIL		
006919	FUELMAN	NP63409688	0	2023	3	INV A		8,467.42	C-010323	FUEL FOR FLEET
006919	FUELMAN	NP63454228	0	2023	3	INV A		8,668.93	C-010323	FUEL FOR FLEET
006919	FUELMAN	NP63486336	0	2023	3	INV A		8,296.93	C-010323	FUEL FOR FLEET
								25,433.28		
								ACCOUNT TOTAL		25,433.28
211	622100							PROFESSIONAL SERVICES		
000305	MEMPHIS ICE MACHINE	119052	0	2023	3	INV A		307.00	C-010323	WEST ICE MACHINE
001136	NWCC-SENATOBIA	121422	0	2023	3	INV A		70.00	C-010323	7 CPR OFFICERS
010525	GORDON LUCIA	SMY10-22	0	2023	3	INV A		75.00	C-010323	STRESS MGMT YOGA (P
013650	BATTERIES PLUS	P58227699	0	2023	3	INV A		139.99	C-010323	CELL PHONE REPAIR-
013650	BATTERIES PLUS	P58227961	0	2023	3	INV A		132.95	C-010323	CELL PHONE REPAIR-
								272.94		
029120	YOUNG LEASING CO	INV6061783	0	2023	3	INV A		512.08	C-010323	#AAA65005 - SID @ W
029120	YOUNG LEASING CO	INV6061901	0	2023	3	INV A		266.38	C-010323	#AAA61322 - ADMIN H
029120	YOUNG LEASING CO	INV6062481	0	2023	3	INV A		178.54	C-010323	#AAA61328 - EVIDENC
029120	YOUNG LEASING CO	INV6087702	0	2023	3	INV A		557.49	C-010323	AAA81006/AAA81007 R
								1,514.49		
032734	ARROWHEAD FORENSICS	154185	0	2023	3	INV A		66.49	C-010323	FINGERPRINT BRUSH
								ACCOUNT TOTAL		2,305.92
211	625700							TELEPHONE & POSTAGE		
000971	PITNEY BOWES GLOBAL	1022173365	0	2023	3	INV A		93.49	C-010323	RED INK CTG POSTAGE
								ACCOUNT TOTAL		93.49
211	626102							PUBLIC RELATIONS		
001361	SAM'S CLUB DIRECT	1-8-23	0	2023	3	INV A		411.20	C-010323	SAM'S CLUB DIRECT 1
005044	LOWE'S HOME CENTERS,	1-15-23	0	2023	3	INV A		473.66	C-010323	896 0 -LOWE'S CREDI
022719	UMB CARD SERVICES	1-2023-0044	0	2023	3	INV A		773.50	C-010323	PURCHASE CARD -0044
								ACCOUNT TOTAL		1,658.36
211	626900							TRAVEL & TRAINING		
001339	CREDIT CARD CENTER	1-13-23	0	2023	3	INV A		4,828.00	C-010323	TRAVEL CARD-1/13/23
010163	MS LAW ENFORCEMENT	12-21-2022	0	2023	3	INV A		1,800.00	C-010323	COURSE/TRAINING: WI
027769	FBINAA	30933	0	2023	3	INV A		120.00	C-010323	ROBERTSON DUES

12/29/2022 12:52
1540spri

CITY OF SOUTHAVEN
FY 2023 CLAIMS DOCKET C-010323

P 9
apinvgl

YEAR/PERIOD: 2023/1 ACCOUNT/VENDOR	TO 2023/4 INVOICE	PO	YEAR/PR	TYP	S	WARRANT	CHECK	DESCRIPTION
027769 FBINAA	47390	0	2023 3	INV	A	120.00	C-010323	SMOROWSKI DUES
027769 FBINAA	50672	0	2023 3	INV	A	120.00	C-010323	MOORE DUES
027769 FBINAA	71488	0	2023 3	INV	A	120.00	C-010323	VICKERS DUES
						480.00		
ACCOUNT TOTAL						7,108.00		
211 630400			MACHINERY & EQUIPMENT					
018285 APPLIED CONCEPTS, IN	411698	23000029	2023 3	INV	A	5,537.00	C-010323	RADAR REPAIR FOR SP
019580 NAVIGATION ELECTRONI	89161	23000105	2023 3	INV	A	35,422.13	C-010323	GPS DEVICE FOR ACCI
ACCOUNT TOTAL						40,959.13		
211 661800			CONFISCATED FUNDS-LOCAL					
006706 LANDERS DODGE	LD185190	23000130	2023 3	INV	A	31,500.00	C-010323	DODGE CHARGER FOR T
ACCOUNT TOTAL						31,500.00		
ORG 211 TOTAL						143,951.65		
215			EMERGENCY SERVICES					
215 610400			OFFICE SUPPLIES					
003626 LIBERTEL ASSOCIATES	230871	0	2023 3	INV	A	483.62	C-010323	HEADSETS
007600 ODP BUSINESS	281142033001	0	2023 3	INV	A	87.00	C-010323	PAPER TOWEL
007600 ODP BUSINESS	281144468001	0	2023 3	INV	A	15.58	C-010323	DISINFECTANT
						102.58		
030629 AMAZON CAPITAL	1VFXYY94QJTN	0	2023 3	INV	A	29.99	C-010323	#ANKP067K88KPB-FILT
ACCOUNT TOTAL						616.19		
215 626900			TRAVEL & TRAINING					
019099 POOLE JOYCE	12-09-2022	0	2023 3	INV	A	276.00	C-010323	PER DIEM-TERMINAL A
020927 OFFICE INNOVATIONS	15389	0	2023 3	INV	A	3,787.76	C-010323	CHAIRS
036836 FIRST RESPONDER TRAI	2022-0012	0	2023 3	INV	A	790.00	C-010323	CLASS 40HR BASIC -
ACCOUNT TOTAL						4,853.76		
ORG 215 TOTAL						5,469.95		
290			FIRE DEPARTMENT					
290 610100			CLEANING SUPPLIES					
007823 AMERICAN PAPER & TWI	4516048	0	2023 3	INV	A	354.07	C-010323	SUPPLIES
ACCOUNT TOTAL						354.07		



12/29/2022 12:52
1540spri

CITY OF SOUTHAVEN
FY 2023 CLAIMS DOCKET C-010323

P 10
apinvgla

YEAR/PERIOD: 2023/1 TO 2023/4	ACCOUNT/VENDOR	INVOICE	PO	YEAR/PR	TYP	S	WARRANT	CHECK	DESCRIPTION
290	611000								MATERIALS
	001102	SOUTHAVEN SUPPLY 165338	0	2023	3	INV A	173.97	C-010323	PUMP HAND PISTON LE
	001102	SOUTHAVEN SUPPLY 165736	0	2023	3	INV A	9.17	C-010323	MATERIALS
	001102	SOUTHAVEN SUPPLY 166507	0	2023	3	INV A	6.99	C-010323	2228-BOX CONNE UNIT
							190.13		
	001121	NEWTONS TROPHY 109991	0	2023	3	INV A	127.00	C-010323	RETIREMENT PLAQUE F
	007304	O'REILLYS AUTO PARTS 1791-196480	0	2023	3	INV A	4.49	C-010323	TIRE GAUGE
	007304	O'REILLYS AUTO PARTS 1791-196482	0	2023	3	CRM A	-4.49	C-010323	CREDIT FOR TIRE GAU
							.00		
	015230	MY-LOR. INC. 4614	0	2023	3	INV A	25.40	C-010323	2 NEW ID TAGS
	030629	AMAZON CAPITAL 19GYQQLF9RCT	0	2023	3	INV A	51.90	C-010323	#ANKP067K88KPB-NYLO
							ACCOUNT TOTAL		394.43
290	611300								MAINTENANCE VEHICLES
	000189	HOMER SKELTON FORD 6156886	0	2023	3	INV A	52.53	C-010323	OIL/FILTER CHANGE F
	000223	CROW'S TRUCK SERVICE R101024933-01	0	2023	3	INV A	1,934.85	C-010323	REPAIRS TO ENG 5, F
	000223	CROW'S TRUCK SERVICE R101025028-01	0	2023	3	INV A	1,128.40	C-010323	REALINED REAR AXLE
							3,063.25		
							ACCOUNT TOTAL		3,115.78
290	612200								MAINTENANCE EQUIPMENT & BUILD
	000305	MEMPHIS ICE MACHINE 119055	0	2023	3	INV A	225.00	C-010323	ANNUAL MAINT. FOR I
	000305	MEMPHIS ICE MACHINE 119058	0	2023	3	INV A	225.00	C-010323	ANNUAL MAINT. FEE F
	000305	MEMPHIS ICE MACHINE 119060	0	2023	3	INV A	225.00	C-010323	ANNUAL MAINTENANCE
	000305	MEMPHIS ICE MACHINE 119061	0	2023	3	INV A	225.00	C-010323	ANNUAL MAINTENANCE
							900.00		
	000650	G & W DIESEL SERVICE 158029	23000065	2023	3	INV A	8,333.38	C-010323	ANNUAL HOLMATRO SER
	020832	EMERGENCY EQUIPMENT 477537	0	2023	3	INV A	184.00	C-010323	SCOTT BATTERY PCB B
	028881	CATES MAINTENANCE CO 73256HC	0	2023	3	INV A	2,299.00	C-010323	WASCOMAT ENCORE WAS
							ACCOUNT TOTAL		11,716.38
290	612500								UNIFORMS
	021916	MIDSOUTH SOLUTIONS 4946	0	2023	3	INV A	450.00	C-010323	UNIFORMS T. JONES
	021916	MIDSOUTH SOLUTIONS 4949	0	2023	3	INV A	450.00	C-010323	UNIFORMS BECERRA
							900.00		



12/29/2022 12:52
1540spri

CITY OF SOUTHAVEN
FY 2023 CLAIMS DOCKET C-010323

P 11
apinvgl

YEAR/PERIOD: 2023/1 ACCOUNT/VENDOR	TO 2023/4 INVOICE	PO	YEAR/PR TYP S	WARRANT	CHECK	DESCRIPTION
ACCOUNT TOTAL				900.00		
290	614000		FUEL & OIL			
006919 FUELMAN	NP63454242	0	2023 3 INV A	89.59	C-010323	#BG127181 - FUEL FO
006919 FUELMAN	NP63486351	0	2023 3 INV A	33.22	C-010323	FUEL
				122.81		
017201 BEST-WADE PETROLEUM	56983	0	2023 3 INV A	2,177.41	C-010323	FUEL FOR STATION 3
017201 BEST-WADE PETROLEUM	56984	0	2023 3 INV A	1,633.05	C-010323	FUEL FOR STATION 2
017201 BEST-WADE PETROLEUM	56985	0	2023 3 INV A	1,940.47	C-010323	FUEL FOR STATION 1
				5,750.93		
ACCOUNT TOTAL				5,873.74		
290	622100		PROFESSIONAL SERVICES			
010525 GORDON LUCIA	SMY10-22	0	2023 3 INV A	75.00	C-010323	STRESS MGMT YOGA (P
ACCOUNT TOTAL				75.00		
290	626900		TRAVEL & TRAINING			
001339 CREDIT CARD CENTER	1-13-23	0	2023 3 INV A	481.23	C-010323	TRAVEL CARD-1/13/23
017547 PARRISH LAMAR	12-20-2022	0	2023 3 INV A	423.00	C-010323	FUNCTIONAL FIREGROU
025680 GRAHAM JOSHUA DALTON	11-10-2022	0	2023 3 INV A	145.00	C-010323	FIRE ACADEMY/ENGINE
025680 GRAHAM JOSHUA DALTON	11-20-22	0	2023 3 INV A	145.00	C-010323	FIRE ACADEMY-FIREGR
				290.00		
029031 HOUSE MICHAEL	12-13-22	0	2023 3 INV A	174.00	C-010323	HAZ-MAT TECHNICIAN
ACCOUNT TOTAL				1,368.23		
290	630400		MACHINERY & EQUIPMENT			
000701 SUNBELT FIRE INC	337951	0	2023 3 INV A	895.00	C-010323	1 ALTAIR GAS MON.
020832 EMERGENCY EQUIPMENT	477556	0	2023 3 INV A	134.00	C-010323	MATERIALS FOR ENGIN
ACCOUNT TOTAL				1,029.00		
ORG 290 TOTAL				24,826.63		
297		EMS	MEDICAL SUPPLIES			
297	610701		MEDICAL SUPPLIES			
000582 BOUND TREE MEDICAL	84793891	0	2023 3 INV A	298.06	C-010323	MEDICAL SUPPLIES
000582 BOUND TREE MEDICAL	84795532	0	2023 3 INV A	950.00	C-010323	MEDICAL SUPPLIES
				1,248.06		
015430 ZOLL MEDICAL CORPORA	3627926	0	2023 3 INV A	735.00	C-010323	MEDICAL SUPPLIES



12/29/2022 12:52
1540spri

CITY OF SOUTHAVEN
FY 2023 CLAIMS DOCKET C-010323

P 12
apinvgl

YEAR/PERIOD: 2023/1 TO 2023/4	ACCOUNT/VENDOR	INVOICE	PO	YEAR/PR	TYP	S	WARRANT	CHECK	DESCRIPTION
	015430 ZOLL MEDICAL CORPORA	3629504	0	2023	3	INV A	1,352.00	C-010323	MEDICAL SUPPLIES
							2,087.00		
	016050 HENRY SCHEIN INC	26901595	0	2023	3	INV A	178.21	C-010323	MEDICAL SUPPLIES
	016050 HENRY SCHEIN INC	30481037	0	2023	3	INV A	102.94	C-010323	MEDICAL SUPPLIES
	016050 HENRY SCHEIN INC	30481101	0	2023	3	INV A	205.88	C-010323	MEDICAL SUPPLIES
	016050 HENRY SCHEIN INC	30511250	0	2023	3	INV A	2,684.83	C-010323	MEDICAL SUPPLIES
	016050 HENRY SCHEIN INC	30758022	0	2023	3	INV A	8.74	C-010323	MEDICAL SUPPLIES
	016050 HENRY SCHEIN INC	31505607	0	2023	3	INV A	1,447.19	C-010323	MEDICAL SUPPLIES
	016050 HENRY SCHEIN INC	31602941	0	2023	3	INV A	25.79	C-010323	MEDICAL SUPPLIES
	016050 HENRY SCHEIN INC	31670491	0	2023	3	INV A	87.50	C-010323	MEDICAL SUPPLIES
							4,741.08		
						ACCOUNT TOTAL	8,076.14		
297	611300					MOTOR VEH REPAIRS/MAINT			
	000189 HOMER SKELTON FORD	6156450	0	2023	3	INV A	1,180.28	C-010323	BRAKES/ROTORS/FRONT
	013654 GATEWAY TIRE &	1008-148308	0	2023	3	INV A	42.50	C-010323	BALANCE FRONT 2 TIR
						ACCOUNT TOTAL	1,222.78		
297	612200					MAINTENANCE EQUIPMENT & BUILD			
	030629 AMAZON CAPITAL	1T4QGMHXQ91M	0	2023	3	INV A	85.98	C-010323	POWER SUPPLY ADAPTE
						ACCOUNT TOTAL	85.98		
297	620901					BILLING SERVICES			
	019311 CREDIT BUREAU SYSTEM	307400000378	0	2023	3	INV A	1,266.17	C-010323	EMS COLLECTION FEES
						ACCOUNT TOTAL	1,266.17		
297	626900					TRAVEL & TRAINING			
	001412 BARNETT RICKEY	121522	0	2023	3	INV A	98.11	C-010323	RENEWAL EMS DRIVERS
	014007 CUNNINGHAM ALLAN	121222	0	2023	3	INV A	65.00	C-010323	RENEWAL OF NREMT&MS
	024000 CARRINGTON JONATHAN	121922	0	2023	3	INV A	65.00	C-010323	RENEWAL OF NRSMT& M
	026915 CLACK JAMES	922022	0	2023	3	INV A	120.00	C-010323	PARAMEDIC SKILLS TE
	034384 OTT HANNAH	121522	0	2023	3	INV A	167.00	C-010323	RENEWAL EMS DRIVER/
						ACCOUNT TOTAL	515.11		
						ORG 297 TOTAL	11,166.18		
311						PUBLIC WORKS DEPARTMENT			
311	610100					CLEANING SUPPLIES			
	001361 SAM'S CLUB DIRECT	1-8-23	0	2023	3	INV A	412.10	C-010323	SAM'S CLUB DIRECT 1



12/29/2022 12:52
1540spri

CITY OF SOUTHAVEN
FY 2023 CLAIMS DOCKET C-010323

P 13
apinvgl

YEAR/PERIOD: 2023/1 TO 2023/4	ACCOUNT/VENDOR	INVOICE	PO	YEAR/PR	TYP	S	WARRANT	CHECK	DESCRIPTION
							ACCOUNT TOTAL		412.10
311	611000						MATERIALS		
	005044	LOWE'S HOME CENTERS, 1-15-23	0	2023	3	INV A	683.49	C-010323	896 0 -LOWE'S CREDI
							ACCOUNT TOTAL		683.49
311	611300						MAINTENANCE VEHICLES		
	000265	MYERS TIRE SUPPLY DI RI25021757001	0	2023	3	INV A	174.20	C-010323	MAT FOR SHOP
	000883	AMERICAN TIRE REPAIR 160862	0	2023	3	INV A	552.75	C-010323	MAT FOR SHOP
	000883	AMERICAN TIRE REPAIR 160864	0	2023	3	INV A	552.75	C-010323	MAT FOR SHOP
	000883	AMERICAN TIRE REPAIR 162587	0	2023	3	INV A	201.31	C-010323	MAT FOR SHOP
							1,306.81		
	000887	JIMMY GRAY CHEVROLET PCP-673332	0	2023	3	INV A	413.43	C-010323	MAT FOR SHOP-PANEL
	000993	ADVANCE AUTO PARTS 1897-543705	0	2023	3	INV A	205.81	C-010323	MAT. FOR SHOP
	000993	ADVANCE AUTO PARTS 1897-543773	0	2023	3	INV A	348.96	C-010323	MAT FOR SHOHP
	000993	ADVANCE AUTO PARTS 6667234737288	0	2023	3	INV A	367.79	C-010323	MAT FOR SHOP
	000993	ADVANCE AUTO PARTS 6667234737306	0	2023	3	CRM A	-50.70	C-010323	CREDIT MAT FOR SHOP
	000993	ADVANCE AUTO PARTS 6667234737307	0	2023	3	INV A	19.68	C-010323	MAT FOR SHOP
	000993	ADVANCE AUTO PARTS 6667235048345	0	2023	3	INV A	37.08	C-010323	MAT FOR SHOP
	000993	ADVANCE AUTO PARTS 6667235437779	0	2023	3	INV A	22.34	C-010323	MAT FOR SHOP
							950.96		
	001114	UNION AUTO PARTS 2476004	0	2023	3	INV A	509.84	C-010323	MAT FOR SHOP
	001150	NAPA GENUINE PARTS C 847293	0	2023	3	INV A	17.98	C-010323	MAT FOR SHOP
	001150	NAPA GENUINE PARTS C 847370	0	2023	3	INV A	58.02	C-010323	MAT FOR SHOP
	001150	NAPA GENUINE PARTS C 847411	0	2023	3	INV A	112.58	C-010323	MAT FOR SHOP
							188.58		
	007304	O'REILLYS AUTO PARTS 1791-200482	0	2023	3	INV A	11.99	C-010323	MAT FOR SHOP
	007304	O'REILLYS AUTO PARTS 1791-200484	0	2023	3	CRM A	-11.99	C-010323	CREDIT
	007304	O'REILLYS AUTO PARTS 6399-134906	0	2023	3	INV A	44.56	C-010323	MAT FOR SHOP
							44.56		
	012748	STRIBLING EQUIPMENT CS017072737	0	2023	3	INV A	371.40	C-010323	MAT FOR SHOP
	013491	GATEWAY TIRE 1023-154457	0	2023	3	INV A	163.39	C-010323	MAT FOR SHOP
	013491	GATEWAY TIRE 1023-154920	0	2023	3	INV A	89.95	C-010323	MAT FOR SHOP
	013491	GATEWAY TIRE 1023-154976	0	2023	3	INV A	91.75	C-010323	MAT FOR SHOP
							345.09		
	035386	EZ DAZE RV PARK B2257	0	2023	3	INV A	109.35	C-010323	PROPANE (MAT FOR SHO



12/29/2022 12:52
1540spri

CITY OF SOUTHAVEN
FY 2023 CLAIMS DOCKET C-010323

P 14
apinvgl

YEAR/PERIOD: 2023/1 TO 2023/4
ACCOUNT/VENDOR INVOICE

ACCOUNT/VENDOR	INVOICE	PO	YEAR/PR	TYP	S	WARRANT	CHECK	DESCRIPTION
					ACCOUNT TOTAL			4,414.22
311 612200								
000669 CAMPER CITY USA INC	460371	0	2023	3	INV A	787.00	C-010323	MAT/EQUIP FOR PW
					ACCOUNT TOTAL			787.00
311 612500								
013377 CINTAS	4138276793	0	2023	3	INV A	434.42	C-010323	UNIFORMS
013377 CINTAS	4139027463	0	2023	3	INV A	434.42	C-010323	UNIFORMS
013377 CINTAS	4141139208	0	2023	3	INV A	432.59	C-010323	UNIFORMS
								1,301.43
					ACCOUNT TOTAL			1,301.43
311 630400								
029563 LANDERS FORD SOUTH	249558	0	2023	3	INV A	43,227.00	C-010323	PW-16961/FORS F250/
					ACCOUNT TOTAL			43,227.00
					ORG 311 TOTAL			50,825.24
					PARKS DEPARTMENT			
411 610400								
006685 DEX IMAGING	AR8484843	0	2023	3	INV A	35.39	C-010323	MP8956- COPY CONTRA
					ACCOUNT TOTAL			35.39
411 612200								
000334 ULINE INC	157752905	0	2023	3	INV A	447.31	C-010323	HAND TRUCK
000709 WILLIAMS EQUIPMENT	S-4019109	0	2023	3	INV A	408.75	C-010323	DRIVE BELT TENSIONE
001361 SAM'S CLUB DIRECT	1-8-23	0	2023	3	INV A	109.32	C-010323	SAM'S CLUB DIRECT 1
005044 LOWE'S HOME CENTERS,	1-15-23	0	2023	3	INV A	764.78	C-010323	896 0 -LOWE'S CREDI
009578 GATEWAY TIRE & SERVI	145301	0	2023	3	INV A	42.60	C-010323	VALUE STEM / MOUNT
009578 GATEWAY TIRE & SERVI	151173	0	2023	3	INV A	280.33	C-010323	TRUCK TIRE
009578 GATEWAY TIRE & SERVI	151347	0	2023	3	INV A	20.40	C-010323	FLAT REPAIR
009578 GATEWAY TIRE & SERVI	151607	0	2023	3	INV A	18.00	C-010323	FLAT REPAIR
009578 GATEWAY TIRE & SERVI	151649	0	2023	3	INV A	183.44	C-010323	TRAILER TIRE
								544.77
013377 CINTAS	4140398013	0	2023	3	INV A	70.45	C-010323	SCRAPER MAT & BLACK
034293 TONY B LOCK AND KEY	996	0	2023	3	INV A	150.00	C-010323	REPAIR BATHROOM LOC
					ACCOUNT TOTAL			2,495.38

12/29/2022 12:52
1540spri

CITY OF SOUTHAVEN
FY 2023 CLAIMS DOCKET C-010323

P 15
apinvgl1a

YEAR/PERIOD: 2023/1	TO 2023/4								
ACCOUNT/VENDOR	INVOICE	PO	YEAR/PR	TYP	S	WARRANT	CHECK	DESCRIPTION	
411 612201								PARK MAINTENANCE	
005044	LOWE'S HOME CENTERS, 1-15-23	0	2023 3	INV	A	39.57	C-010323	896 0 -LOWE'S CREDI	
007823	AMERICAN PAPER & TWI 4517148	0	2023 3	INV	A	52.30	C-010323	JANITORIAL	
033222	THE SOCCER CORNER 79047	23000035	2023 3	INV	A	6,290.00	C-010323	SOCCER GOALS	
	ACCOUNT TOTAL					6,381.87			
411 613400								COMMUNITY EVENTS	
001361	SAM'S CLUB DIRECT 1-8-23	0	2023 3	INV	A	769.36	C-010323	SAM'S CLUB DIRECT 1	
027454	ARGO ENTERTAINMENT 12-21-2022	0	2023 3	INV	A	32,500.00	C-010323	BOARD APPROVED CONT	
	ACCOUNT TOTAL					33,269.36			
411 621900								ASSOCIATIONAL DUES	
001339	CREDIT CARD CENTER 1-13-23	0	2023 3	INV	A	315.00	C-010323	TRAVEL CARD-1/13/23	
	ACCOUNT TOTAL					315.00			
411 626900								TRAVEL & TRAINING	
001339	CREDIT CARD CENTER 1-13-23	0	2023 3	INV	A	315.00	C-010323	TRAVEL CARD-1/13/23	
	ACCOUNT TOTAL					315.00			
411 627901								UMPIRES	
002574	CARSON MICHAEL A 12-27-22	0	2023 3	INV	A	140.00	C-010323	INDOOR SOCCER UMPIR	
015545	KLINCK ZACHARY A 12-27-22	0	2023 3	INV	A	160.00	C-010323	INDOOR SOCCER UMPIR	
015810	MEARS MICHAEL 12-27-22	0	2023 3	INV	A	140.00	C-010323	INDOOR SOCCER UMPIR	
018253	CHAN DAVID 12-27-22	0	2023 3	INV	A	140.00	C-010323	INDOOR SOCCER UMPIR	
018255	PHILLIPS ERIC 12-27-22	0	2023 3	INV	A	105.00	C-010323	INDOOR SOCCER UMPIR	
028218	COX III DAVID ROYAL 12-27-22	0	2023 3	INV	A	280.00	C-010323	INDOOR SOCCER UMPIR	
031322	VASQUEZ GEORGE 12-27-22	0	2023 3	INV	A	140.00	C-010323	INDOOR SOCCER UMPIR	
035271	GRAHAM STEPHEN 12-27-22	0	2023 3	INV	A	105.00	C-010323	INDOOR SOCCER UMPIR	
036078	BEAL BLAKE AUSTIN 12-18-22	0	2023 3	INV	A	70.00	C-010323	SOFTBALL UMPIRE DEC	
036319	TOWELL ETHAN 12-27-22	0	2023 3	INV	A	140.00	C-010323	INDOOR SOCCER UMPIR	
036350	SIMPSON SPENSER 12-27-22	0	2023 3	INV	A	210.00	C-010323	INDOOR SOCCER UMPIR	
	ACCOUNT TOTAL					1,630.00			



12/29/2022 12:52
1540spri

CITY OF SOUTHAVEN
FY 2023 CLAIMS DOCKET C-010323

P 16
apinvgl

YEAR/PERIOD:	2023/1	TO	2023/4							
ACCOUNT/VENDOR		INVOICE		PO	YEAR/PR	TYP	S	WARRANT	CHECK	DESCRIPTION
					ORG 411	TOTAL		44,442.00		
412					PARK TOURNAMENTS					
412	612400					RESELL / CONCESSION	EXPENSE			
001361	SAM'S CLUB DIRECT	1-8-23		0	2023	3	INV A	731.87	C-010323	SAM'S CLUB DIRECT 1
007885	PAULSEN PRINTING COM	112099		0	2023	3	INV A	410.00	C-010323	VOLLEYBALL TICKETS
022105	NCR CORPORATION	6503179083		0	2023	3	INV A	717.50	C-010323	ALOHA SUPPORT
026772	WILSON SPORTING GOOD	4540177964		0	2023	3	INV A	418.72	C-010323	TENNIS RACKET - RES
						ACCOUNT TOTAL		2,278.09		
412	622100					PROFESSIONAL FEES				
007622	MIDSOUTH SPORTS PROD	718		0	2023	3	INV A	11,250.00	C-010323	BASEBALL CONTRACT J
024247	KALISAK ROSEMARY	DEC2022		0	2023	3	INV A	3,750.00	C-010323	SOFTBALL CONTRACT D
						ACCOUNT TOTAL		15,000.00		
					ORG 412	TOTAL		17,278.09		
511						MUNICIPAL CODE ENFORCEMENT				
511	610100					CLEANING SUPPLIES				
001361	SAM'S CLUB DIRECT	1-8-23		0	2023	3	INV A	101.19	C-010323	SAM'S CLUB DIRECT 1
005044	LOWE'S HOME CENTERS,	1-15-23		0	2023	3	INV A	76.04	C-010323	896 0 -LOWE'S CREDI
						ACCOUNT TOTAL		177.23		
511	610400					OFFICE SUPPLIES				
029120	YOUNG LEASING CO	INV6084831		0	2023	3	INV A	169.35	C-010323	OFFICE SUPPLIES
						ACCOUNT TOTAL		169.35		
511	611000					MATERIALS				
000246	ANIMAL CARE EQUIPMEN	108138		0	2023	3	INV A	158.26	C-010323	MATERIALS
001102	SOUTHAVEN SUPPLY	165404		0	2023	3	INV A	5.56	C-010323	MATERIALS
						ACCOUNT TOTAL		163.82		
511	630400					MACHINERY & EQUIPMENT				
005044	LOWE'S HOME CENTERS,	1-15-23		0	2023	3	INV A	75.99	C-010323	896 0 -LOWE'S CREDI
						ACCOUNT TOTAL		75.99		
					ORG 511	TOTAL		586.39		



12/29/2022 12:52
1540spri

CITY OF SOUTHAVEN
FY 2023 CLAIMS DOCKET C-010323

P 17
apinvgl

YEAR/PERIOD: 2023/1 TO 2023/4
ACCOUNT/VENDOR INVOICE

PO YEAR/PR TYP S WARRANT CHECK DESCRIPTION

YEAR/PERIOD:	ACCOUNT/VENDOR	INVOICE	PO	YEAR/PR	TYP	S	WARRANT	CHECK	DESCRIPTION		
902											
902	620902								EXPENSE ACCOUNTS		
	000305	MEMPHIS ICE MACHINE 119057	0	2023	3	INV A	225.00	C-010323	FACILITIES MANAGEMENT ANNUAL ICE MACHINE		
	005044	LOWE'S HOME CENTERS, 1-15-23	0	2023	3	INV A	2,836.13	C-010323	896 0 -LOWE'S CREDI		
	019694	MID-SOUTH TELECOM 75109	0	2023	3	INV A	65.00	C-010323	PHONE SERVICE		
	019694	MID-SOUTH TELECOM 75400	0	2023	3	INV A	65.00	C-010323	PHONE SERVICE FOR C		
	019694	MID-SOUTH TELECOM 75407	0	2023	3	INV A	130.00	C-010323	PHONE SERVICE @ POL		
	019694	MID-SOUTH TELECOM 75450	0	2023	3	INV A	1,176.00	C-010323	PHONE SERVICE @ NEW		
							1,436.00				
							ACCOUNT TOTAL		4,497.13		
							ORG 902		TOTAL 4,497.13		
903									ADMINISTRATIVE EXPENSES		
903	624102								BANK FEES		
	013790	HANCOCK BANK 39644	0	2023	3	INV A	900.00	C-010323	SOUTHGORF415-S/A PA		
							ACCOUNT TOTAL		900.00		
							ORG 903		TOTAL 900.00		
=====							FUND 0010	GENERAL FUND	TOTAL:	322,334.73	
=====							=====				



12/29/2022 12:52
1540spri

CITY OF SOUTHAVEN
FY 2023 CLAIMS DOCKET C-010323

P 18
apinvgl

YEAR/PERIOD:	2023/1	TO	2023/4							
ACCOUNT/VENDOR		INVOICE	PO	YEAR/PR	TYP	S	WARRANT	CHECK	DESCRIPTION	
811									UTILITY EXPENSE ACCOUNTS	
811	650901								HORN LAKE CREEK BASIN LOAN PYM	
	002848	HORN LAKE CREEK BASI 12-20-22	0	2023	3	INV A	2,787.69	C-010323	DEC. 2022 HL CREEK	
							ACCOUNT TOTAL		2,787.69	
811	650905								DCRUA SEWER TREATMENT FEE	
	004646	DESOTO COUNTY REGION 2881	0	2023	3	INV A	87,127.25	C-010323	JAN 2023 SEWER FEES	
							ACCOUNT TOTAL		87,127.25	
				ORG 811		TOTAL	89,914.94			
815									UTILITY CAPITAL IMPROVEMENTS	
815	625300								EXTENSION & OTHER IMPROVEMENTS	
	005044	LOWE'S HOME CENTERS, 1-15-23	0	2023	3	INV A	1,291.05	C-010323	896 0 -LOWE'S CREDI	
	015242	TREY CONSTRUCTION, I PAY-APP2	0	2023	3	INV A	317,870.00	C-010323	FIRE SERVICE EXT. P	
							ACCOUNT TOTAL		319,161.05	
815	625305								SANITARY SEWER EXTENSION	
	004494	J R STEWART 36355	23000133	2023	3	INV A	14,944.16	C-010323	(SOLE SOURCE) CONTR	
							ACCOUNT TOTAL		14,944.16	
815	625310								CAPITAL IMPROVEMENTS	
	033110	MEMPHIS FLOORING CO 16389	23000064	2023	3	INV A	23,000.00	C-010323	7411 HWY 51 NORTH O	
							ACCOUNT TOTAL		23,000.00	
				ORG 815		TOTAL	357,105.21			
820									UTILITY ADMINISTRATIVE EXPENSE	
820	610400								OFFICE SUPPLIES	
	007600	ODP BUSINESS 274072469001	0	2023	3	INV A	135.34	C-010323	CALCULATOR/LAMINATI	
							ACCOUNT TOTAL		135.34	
				ORG 820		TOTAL	135.34			
825									UTILITY MAINTENANCE EXPENSES	
825	611000								MATERIALS	
	000354	METER SERVICE AND SU 28983	0	2023	3	INV A	4,284.00	C-010323	SEWER PIPE	
	000354	METER SERVICE AND SU 29000	0	2023	3	INV A	114.00	C-010323	COUPLINGS	
	000354	METER SERVICE AND SU 29017	0	2023	3	INV A	2,913.45	C-010323	CURBSTOPS & COUPLIN	
							7,311.45			
	000551	USA BLUEBOOK 199380	0	2023	3	INV A	118.70	C-010323	DEIONIZED WATER	

12/29/2022 12:52
1540spri

CITY OF SOUTHAVEN
FY 2023 CLAIMS DOCKET C-010323

P 19
apinvgla

YEAR/PERIOD: 2023/1	TO 2023/4	ACCOUNT/VENDOR	INVOICE	PO	YEAR/PR	TYP	S	WARRANT	CHECK	DESCRIPTION
000687		SOUTHERN PIPE & SUPP	7463402	0	2023	3	INV A	208.50	C-010323	TUBING CUTTER & WHE
000915		HOME DEPOT CREDIT SE	1173793	0	2023	3	CRM A	-329.00	C-010323	MOWER RETURN CREDIT
000915		HOME DEPOT CREDIT SE	3014796	0	2023	3	INV A	631.51	C-010323	MISC MATERIALS
000915		HOME DEPOT CREDIT SE	3222355	0	2023	3	CRM A	-41.31	C-010323	CREDIT FOR TAXES CH
								261.20		
001102		SOUTHAVEN SUPPLY	166309	0	2023	3	INV A	1,157.36	C-010323	MISC SUPPLIES
001150		NAPA GENUINE PARTS C	847672	0	2023	3	INV A	60.23	C-010323	OIL & FUNNEL TRUCK
001361		SAM'S CLUB DIRECT	1-8-23	0	2023	3	INV A	371.39	C-010323	SAM'S CLUB DIRECT 1
004246		HARBOR FREIGHT TOOLS	2788065	0	2023	3	INV A	149.99	C-010323	WINCH
005044		LOWE'S HOME CENTERS,	1-15-23	0	2023	3	INV A	1,842.26	C-010323	896 0 -LOWE'S CREDI
007304		O'REILLYS AUTO PARTS	1257-202205	0	2023	3	INV A	26.98	C-010323	BRUSH AND WASHWAX
010919		TRACTOR SUPPLY CREDI	300260065	0	2023	3	INV A	547.89	C-010323	WINTER STORM 2022 M
010919		TRACTOR SUPPLY CREDI	300260465	0	2023	3	INV A	1,085.91	C-010323	MATERIALF FOR WINTE
								1,633.80		
011578		CORE & MAIN LP	S047611	0	2023	3	INV A	892.11	C-010323	FITTINGS
011578		CORE & MAIN LP	S069888	0	2023	3	INV A	1,330.50	C-010323	COUPLINGS & VALVE B
011578		CORE & MAIN LP	S075863	0	2023	3	INV A	1,774.70	C-010323	GATE VALVE FOR FOXC
								3,997.31		
015408		J & J MAINTENANCE SU	15590	0	2023	3	INV A	799.50	C-010323	BLUE & GREEN MARKIN
029563		LANDERS FORD SOUTH	229041	0	2023	3	INV A	355.36	C-010323	LINER & KIT
029563		LANDERS FORD SOUTH	229042	0	2023	3	INV A	355.36	C-010323	KIT & LINER
								710.72		
ACCOUNT TOTAL								18,649.39		
825	611100				CHEMICALS					
001146		IDEAL CHEMICAL	277646	0	2023	3	INV A	3,261.60	C-010323	CHEMICALS FOR WHITW
001146		IDEAL CHEMICAL	277647	0	2023	3	INV A	467.50	C-010323	FLUORIDE FOR GREENB
001146		IDEAL CHEMICAL	277648	0	2023	3	INV A	3,729.10	C-010323	CHEMICALS FOR GETWE
001146		IDEAL CHEMICAL	277778	0	2023	3	INV A	800.00	C-010323	TANKS & EQUIP FOR W
001146		IDEAL CHEMICAL	277797	0	2023	3	INV A	3,261.60	C-010323	CHEMICALS FOR GREEN
001146		IDEAL CHEMICAL	277798	0	2023	3	INV A	1,293.10	C-010323	CHEMICALS FOR COLLE
								12,812.90		
005073		MOMAR	PSI479598	0	2023	3	INV A	207.99	C-010323	DISINFECTANT



12/29/2022 12:52
1540spri

CITY OF SOUTHAVEN
FY 2023 CLAIMS DOCKET C-010323

P 20
apinvgl

YEAR/PERIOD: 2023/1 TO 2023/4	ACCOUNT/VENDOR	INVOICE	PO	YEAR/PR	TYP	S	WARRANT	CHECK	DESCRIPTION
ACCOUNT TOTAL							13,020.89		
825	611300			MAINTENANCE VEHICLES					
	001150	NAPA GENUINE PARTS C 847361	0	2023	3	INV A	29.79	C-010323	WIPER BLADES TRUCK
	001150	NAPA GENUINE PARTS C 847511	0	2023	3	INV A	27.98	C-010323	ANTIFREEZE
							57.77		
	006706	LANDERS DODGE 341325	0	2023	3	INV A	78.71	C-010323	ROUTINE MAINTENANCE
	029563	LANDERS FORD SOUTH 147109	0	2023	3	INV A	176.88	C-010323	ROUTINE MAINTENANCE
	029563	LANDERS FORD SOUTH 147127	0	2023	3	INV A	564.43	C-010323	REPAIRS TO TRUCK #8
							741.31		
ACCOUNT TOTAL							877.79		
825	612200			MAINTENANCE EQUIPMENT & BUILD					
	000070	AERIAL TRUCK EQUIP C 8358	0	2023	3	INV A	960.00	C-010323	BACK UP CAMERA
	000883	AMERICAN TIRE REPAIR 162923	0	2023	3	INV A	750.00	C-010323	TIRE REPAIRS ON TRA
ACCOUNT TOTAL							1,710.00		
825	612500			UNIFORMS					
	030629	AMAZON CAPITAL 19PDWFMP99P6	0	2023	3	INV A	254.88	C-010323	UNIFORM WADERS
	030629	AMAZON CAPITAL 1FKXXNQ44MDF	0	2023	3	INV A	131.96	C-010323	UNIFORM WADERS
							386.84		
	034854	CAVENDERS BOOT CITY 178066-IN	0	2023	3	INV A	111.73	C-010323	UNIFORMS HAAKEN THO
	034854	CAVENDERS BOOT CITY 178067-IN	0	2023	3	INV A	125.00	C-010323	UNIFORM BOOTS - STE
	034854	CAVENDERS BOOT CITY 178068-IN	0	2023	3	INV A	125.00	C-010323	UNIFORM BOOTS - ROB
	034854	CAVENDERS BOOT CITY 178069-IN	0	2023	3	INV A	125.00	C-010323	UNIFORM BOOTS - TRA
	034854	CAVENDERS BOOT CITY 178070-IN	0	2023	3	INV A	125.00	C-010323	UNIFORM BOOTS - MIC
	034854	CAVENDERS BOOT CITY 178071-IN	0	2023	3	INV A	125.00	C-010323	UNIFORM BOOTS - JOH
	034854	CAVENDERS BOOT CITY 178072-IN	0	2023	3	INV A	125.00	C-010323	UNIFORM BOOTS - DYL
	034854	CAVENDERS BOOT CITY 178184-IN	0	2023	3	INV A	125.00	C-010323	UNIFORMS BOOTS PIER
	034854	CAVENDERS BOOT CITY 178185-IN	0	2023	3	INV A	125.00	C-010323	UNIFORM BOOTS PAXTO
							1,111.73		
ACCOUNT TOTAL							1,498.57		
825	614000			FUEL & OIL					
	025130	BULLFROG MART LLC 1011343	0	2023	3	INV A	170.54	C-010323	FUEL FOR SMALL EQUI
ACCOUNT TOTAL							170.54		
825	622100			PROFESSIONAL SERVICES					
	009195	GAINES, ROBERT 1263	0	2023	3	INV A	5,232.50	C-010323	SCADA SERVICES



12/29/2022 12:52
1540spri

CITY OF SOUTHAVEN
FY 2023 CLAIMS DOCKET C-010323

P 21
apinvgl

YEAR/PERIOD: 2023/1 TO 2023/4	ACCOUNT/VENDOR	INVOICE	PO	YEAR/PR	TYP	S	WARRANT	CHECK	DESCRIPTION	
	018472 M2MANAGEMENT SOLUTIO	2868	0	2023	3	INV A	1,602.35	C-010323	FLEET TRACKING SYST	
						ACCOUNT TOTAL	6,834.85			
825	624500					LICENSES & MISCELLANEOUS FEES				
	022719 UMB CARD SERVICES	1-2023-0044	0	2023	3	INV A	575.00	C-010323	PURCHASE CARD -0044	
						ACCOUNT TOTAL	575.00			
825	630600					VEHICLES				
	029563 LANDERS FORD SOUTH	249534	23000140	2023	3	INV A	43,328.00	C-010323	UTILITIES FORD F350	
	029563 LANDERS FORD SOUTH	249597	23000139	2023	3	INV A	37,923.00	C-010323	UTILITIES FORD F350	
							81,251.00			
						ACCOUNT TOTAL	81,251.00			
825	650903					INTERCEPTOR SEWER TREATMENT				
	002848 HORN LAKE CREEK BASI	12-20-2022	0	2023	3	INV A	153,124.48	C-010323	DEC 2022 SEWER FEES	
						ACCOUNT TOTAL	153,124.48			
						ORG 825 TOTAL	277,712.51			
=====										
FUND 0400 UTILITY FUND							TOTAL:	724,868.00	=====	

** END OF REPORT - Generated by Sonya Pride **



12/29/2022 12:43
1540spri

CITY OF SOUTHAVEN
FY 2023 CLAIMS DOCKET D-010323

P 2
apinvgla

YEAR/PERIOD: 2023/1 TO 2023/4								
ACCOUNT/VENDOR	INVOICE	PO	YEAR/PR	TYP	S	WARRANT	CHECK	DESCRIPTION
			ORG 160	TOTAL		10.00		
180			PLANNING / ENGINEERING DEPT					
180	614000		GASOLINE/OIL					
021382	PETTY CASH	12-16-2022	0	2023	3 INV P	95.69	D-010323	200799 PETTY CASH/CITY CLE
					ACCOUNT TOTAL	95.69		
180	622100		PROFESSIONAL FEES					
004781	FAMILY MEDICAL CLINI	12922	0	2023	3 INV P	240.00	D-010323	200786 PRE-EMPLOYMENT SCRE
021382	PETTY CASH	12-16-2022	0	2023	3 INV P	34.00	D-010323	200799 PETTY CASH/CITY CLE
					ACCOUNT TOTAL	274.00		
180	625700		TELEPHONE/POSTAGE					
001095	VERIZON WIRELESS	9921887476	0	2023	3 INV P	820.22	D-010323	200801 642151677-00001/DEC
					ACCOUNT TOTAL	820.22		
			ORG 180	TOTAL		1,189.91		
211			POLICE DEPARTMENT					
211	611300		MAINTENANCE VEHICLES					
002352	DEPARTMENT OF REVENU	12-22-22	0	2023	3 INV A	12.00	D-010323	TAG/MAIL FEE 2012 C
002352	DEPARTMENT OF REVENU	G047334-SPD	0	2023	3 INV P	12.00	D-010323	200795 TAG & MAIL/2022 BBT
002352	DEPARTMENT OF REVENU	H240971-SPD	0	2023	3 INV P	12.00	D-010323	200793 TAG & MAIL/2022 DOD
002352	DEPARTMENT OF REVENU	H240975-SPD	0	2023	3 INV P	12.00	D-010323	200794 TAG & MAIL/2022 DOD
						48.00		
021382	PETTY CASH	12-16-2022	0	2023	3 INV P	20.00	D-010323	200799 PETTY CASH/CITY CLE
					ACCOUNT TOTAL	68.00		
211	622100		PROFESSIONAL SERVICES					
004781	FAMILY MEDICAL CLINI	12922	0	2023	3 INV P	80.00	D-010323	200786 PRE-EMPLOYMENT SCRE
004781	FAMILY MEDICAL CLINI	12922-POLICE	0	2023	3 INV P	1,060.00	D-010323	200788 PRE-EMPLOYMENT SCRE
						1,140.00		
					ACCOUNT TOTAL	1,140.00		
211	625700		TELEPHONE & POSTAGE					
001095	VERIZON WIRELESS	9921887476	0	2023	3 INV P	5,297.22	D-010323	200801 642151677-00001/DEC
					ACCOUNT TOTAL	5,297.22		
211	626000		UTILITIES					
001145	ATMOS ENERGY	50342-120222	0	2023	3 INV A	237.68	D-010323	4008850342- 1855 VE



12/29/2022 12:43
1540spri

CITY OF SOUTHAVEN
FY 2023 CLAIMS DOCKET D-010323

P 3
apinvgl

YEAR/PERIOD: 2023/1	TO 2023/4							
ACCOUNT/VENDOR	INVOICE	PO	YEAR/PR	TYP S	WARRANT	CHECK	DESCRIPTION	
				ACCOUNT TOTAL				237.68
211 661800				CONFISCATED FUNDS-LOCAL				
034574 DATAPILOT INC	12-15-2022	0	2023 3	INV P	995.00 D-010323	200785	COURSE FEE FOR DETE	
				ACCOUNT TOTAL				995.00
			ORG 211	TOTAL				7,737.90
215				EMERGENCY SERVICES				
215 622100				PROFESSIONAL FEES				
004781 FAMILY MEDICAL CLINI	12922	0	2023 3	INV P	80.00 D-010323	200786	PRE-EMPLOYMENT SCRE	
				ACCOUNT TOTAL				80.00
			ORG 215	TOTAL				80.00
290				FIRE DEPARTMENT				
290 611300				MAINTENANCE VEHICLES				
021382 PETTY CASH	12-16-2022	0	2023 3	INV P	62.49 D-010323	200799	PETTY CASH/CITY CLE	
				ACCOUNT TOTAL				62.49
290 622100				PROFESSIONAL SERVICES				
004781 FAMILY MEDICAL CLINI	12922-FIRE	0	2023 3	INV P	751.00 D-010323	200787	PRE-EMPLOYMENT SCRE	
				ACCOUNT TOTAL				751.00
290 625700				TELEPHONE & POSTAGE				
001095 VERIZON WIRELESS	9921887476	0	2023 3	INV P	960.48 D-010323	200801	642151677-00001/DEC	
001137 FEDEX	7-976-97341	0	2023 3	INV A	74.08 D-010323		SHIPPING FEES	
				ACCOUNT TOTAL				1,034.56
290 626000				UTILITIES				
000966 ENTERGY	110007280171	0	2023 3	INV A	174.74 D-010323		50134691-8945 TULLA	
000966 ENTERGY	110007280229	0	2023 3	INV A	1,174.06 D-010323		51589596-1940 STATE	
000966 ENTERGY	245006215727	0	2023 3	INV A	938.89 D-010323		79401667-7980 SWINN	
								2,287.69
001145 ATMOS ENERGY	2695-121322	0	2023 3	INV A	840.91 D-010323		3019672695-7980 SWI	
				ACCOUNT TOTAL				3,128.60
290 626900				TRAVEL & TRAINING				
021382 PETTY CASH	12-16-2022	0	2023 3	INV P	69.54 D-010323	200799	PETTY CASH/CITY CLE	
				ACCOUNT TOTAL				69.54
			ORG 290	TOTAL				5,046.19



12/29/2022 12:43
1540spri

CITY OF SOUTHAVEN
FY 2023 CLAIMS DOCKET D-010323

P 4
apinvgl

YEAR/PERIOD: 2023/1 TO 2023/4
ACCOUNT/VENDOR INVOICE

PO YEAR/PR TYP S WARRANT CHECK DESCRIPTION

YEAR/PERIOD:	2023/1	TO	2023/4	ACCOUNT/VENDOR	INVOICE	PO	YEAR/PR	TYP	S	WARRANT	CHECK	DESCRIPTION
FIRE PREVENTION												
295	611000											
295	021382	PETTY CASH	12-16-2022			0	2023	3	INV P	9.99	D-010323	200799 PETTY CASH/CITY CLE
										9.99		ACCOUNT TOTAL
										9.99		ORG 295 TOTAL
PUBLIC WORKS DEPARTMENT												
311	611300											
311	002352	DEPARTMENT OF REVENUE	NEG16960-PW			0	2023	3	INV P	12.00	D-010323	200792 TAG & MAIL FEE/2022
	002352	DEPARTMENT OF REVENUE	NEG16961-PW			0	2023	3	INV P	12.00	D-010323	200790 TAG & MAIL/2022 FOR
	002352	DEPARTMENT OF REVENUE	NEG16962-PW			0	2023	3	INV P	12.00	D-010323	200791 TAG & MAIL FEE/2022
										36.00		
										36.00		ACCOUNT TOTAL
										76.01		ORG 311 TOTAL
TELEPHONE & POSTAGE												
311	625700											
311	001095	VERIZON WIRELESS	9921887476			0	2023	3	INV P	40.01	D-010323	200801 642151677-00001/DEC
										40.01		ACCOUNT TOTAL
										76.01		ORG 311 TOTAL
PARKS DEPARTMENT												
411	600100											
411	036833	GREGG GARY	12-19-2022			0	2023	3	INV P	1,200.35	D-010323	200796 GARY GREGG-UNPAID D
	036834	GREGG JOEY	12-19-2022			0	2023	3	INV P	1,200.35	D-010323	200797 GARY GREGG-UNPAID D
										2,400.70		ACCOUNT TOTAL
PROFESSIONAL SERVICES												
411	622100											
411	004781	FAMILY MEDICAL CLINI	12922			0	2023	3	INV P	80.00	D-010323	200786 PRE-EMPLOYMENT SCRE
										80.00		ACCOUNT TOTAL
TELEPHONE & POSTAGE												
411	625700											
411	001095	VERIZON WIRELESS	9921887476			0	2023	3	INV P	480.14	D-010323	200801 642151677-00001/DEC
	013136	AT&T	1874-112822			0	2023	3	INV A	102.75	D-010323	662 280-5136 646 18
										582.89		ACCOUNT TOTAL
UTILITIES												
411	626000											
411	000966	ENTERGY	145006923741			0	2023	3	INV A	3,717.89	D-010323	44368587-3335 PINE
	000966	ENTERGY	150005820462			0	2023	3	INV A	81.90	D-010323	119242972-7635 TCHU
	000966	ENTERGY	15007826986			0	2023	3	INV A	95.26	D-010323	47805247-6208 SNOWD
	000966	ENTERGY	155006865378			0	2023	3	INV A	168.91	D-010323	16833329-3278 MAY B
	000966	ENTERGY	155006865379			0	2023	3	INV A	27.04	D-010323	16834020-GETWELL &



12/29/2022 12:43
1540spri

CITY OF SOUTHAVEN
FY 2023 CLAIMS DOCKET D-010323

P 5
apinvgl

YEAR/PERIOD: 2023/1 TO 2023/4
ACCOUNT/VENDOR INVOICE

PO

YEAR/PR TYP S

WARRANT

CHECK

DESCRIPTION

000966	ENTERGY	155006865381	0	2023	3	INV A	152.10	D-010323	16837304-6205 SNOWD
000966	ENTERGY	155006865383	0	2023	3	INV A	444.45	D-010323	16852006-7505 STONE
000966	ENTERGY	160005799455	0	2023	3	INV A	62.03	D-010323	16836884-CHAPARRAL
000966	ENTERGY	160005799456	0	2023	3	INV A	309.09	D-010323	16838617-SNOWDEN PA
000966	ENTERGY	160005808721	0	2023	3	INV A	27.04	D-010323	16838419-7505 CHERR
000966	ENTERGY	160005808723	0	2023	3	INV A	436.44	D-010323	16839250-7505 CHERR
000966	ENTERGY	195006943539	0	2023	3	INV A	1,420.62	D-010323	12335762 - 800 STOW
000966	ENTERGY	20008701601	0	2023	3	INV A	84.19	D-010323	31109259-7705 TCHUL
000966	ENTERGY	20008701602	0	2023	3	INV A	63.43	D-010323	31109317-7655 TCHUL
000966	ENTERGY	20008701603	0	2023	3	INV A	95.26	D-010323	31109366-7625 TCHUL
000966	ENTERGY	20008701604	0	2023	3	INV A	87.59	D-010323	31109424-7635 TCHUL
000966	ENTERGY	20008701605	0	2023	3	INV A	74.09	D-010323	31109473-7255 TCHUL
000966	ENTERGY	20008701606	0	2023	3	INV A	59.60	D-010323	31109549-7535 TCHUL
000966	ENTERGY	20008701607	0	2023	3	INV A	68.41	D-010323	31109614-7645 TCHUL
000966	ENTERGY	20008701608	0	2023	3	INV A	27.04	D-010323	31109648-7665 TCHUL
000966	ENTERGY	280005473400	0	2023	3	INV A	1,602.42	D-010323	171475650-6650 SNOW
000966	ENTERGY	290005469987	0	2023	3	INV A	157.88	D-010323	15928989 - 8400 GRE
000966	ENTERGY	315005301474	0	2023	3	INV A	208.23	D-010323	182817924-6277D SNO
000966	ENTERGY	315005301475	0	2023	3	INV A	152.15	D-010323	182817932-6277C SNO
000966	ENTERGY	335005170144	0	2023	3	INV A	493.30	D-010323	18054049-SNOWDEN BA
000966	ENTERGY	345005065616	0	2023	3	INV A	95.82	D-010323	19046929-1978 STATE
000966	ENTERGY	365004931532	0	2023	3	INV A	129.41	D-010323	19046408-3025 CARNI
000966	ENTERGY	405004444942	0	2023	3	INV A	711.70	D-010323	20892766-6070 SNOWD
000966	ENTERGY	40500444943	0	2023	3	INV A	423.14	D-010323	20291415-3480 SUNSE
000966	ENTERGY	435004309557	0	2023	3	INV A	628.20	D-010323	38124624-CHERRY VAL
000966	ENTERGY	455004170085	0	2023	3	INV A	52.20	D-010323	66762873-6275 SNOWD
000966	ENTERGY	495003991455	0	2023	3	INV A	318.76	D-010323	66074311-6208A SNOW
000966	ENTERGY	540001552555	0	2023	3	INV A	27.74	D-010323	117424333-1729 BROO
000966	ENTERGY	55007425002	0	2023	3	INV A	2,957.16	D-010323	15744642-3376 NAIL
000966	ENTERGY	90007358409	0	2023	3	INV A	27.04	D-010323	72820194-6305 SNOWD
000966	ENTERGY	90007358410	0	2023	3	INV A	142.04	D-010323	74855255-6277B SNOW
000966	ENTERGY	90007358411	0	2023	3	INV A	117.47	D-010323	74869355-6277A SNOW

15,747.04

001105	NORTHCENTRAL ELECTRI	7010-112322	0	2023	3	INV A	644.79	D-010323	59247010-3750 FREEM
001145	ATMOS ENERGY	1167-121322	0	2023	3	INV A	525.55	D-010323	4034951167-740 STOW
001145	ATMOS ENERGY	2435-121422	0	2023	3	INV A	70.91	D-010323	3019672435- 8400 GR
001145	ATMOS ENERGY	3076-121322	0	2023	3	INV A	152.10	D-010323	3020713076 - 8925 S
001145	ATMOS ENERGY	3727-121422	0	2023	3	INV A	22.93	D-010323	4010573727- 800 STO
001145	ATMOS ENERGY	7730-120222	0	2023	3	INV A	101.58	D-010323	3015017730-1320 BRO

873.07

001234	BRIGHTSPEED	200022-121022	0	2023	3	INV A	931.60	D-010323	400200022- PARKS PH
001234	BRIGHTSPEED	3210-120222	0	2023	3	INV A	173.75	D-010323	465283210- TENNIS P

1,105.35

016529	DIRECTV	18993796X221209	0	2023	3	INV A	93.08	D-010323	018993796 - UMPIRE
--------	---------	-----------------	---	------	---	-------	-------	----------	--------------------



12/29/2022 12:43
1540spri

CITY OF SOUTHAVEN
FY 2023 CLAIMS DOCKET D-010323

P 6
apinvgl

YEAR/PERIOD: 2023/1 TO 2023/4	ACCOUNT/VENDOR	INVOICE	PO	YEAR/PR	TYP	S	WARRANT	CHECK	DESCRIPTION	
				ACCOUNT TOTAL			18,463.33			
			ORG 411	TOTAL			21,526.92			
	EXPENSE ACCOUNTS									
902	620902			FACILITIES MANAGEMENT						
000966	ENTERGY	140005817887	0	2023	3	INV A	74.59	D-010323	60209269-7111 TCHUL	
000966	ENTERGY	20008694709	0	2023	3	INV A	38.13	D-010323	109997221-2009 STAR	
000966	ENTERGY	20008694710	0	2023	3	INV A	44.09	D-010323	109997247-165 STAR	
							156.81			
001145	ATMOS ENERGY	1048-122222	0	2023	3	INV A	920.91	D-010323	4045331048 - 7312 H	
013136	AT&T	41875-112822	0	2023	3	INV P	35.37	D-010323	200789 662 342-7078 304 18	
				ACCOUNT TOTAL			1,113.09			
902	622100			PROFESSIONAL SERVICES						
022644	CORPORATE PLANNING	57562	0	2023	3	INV P	1,045.00	D-010323	200784 DECEMBER 2022 FSA M	
				ACCOUNT TOTAL			1,045.00			
			ORG 902	TOTAL			2,158.09			
=====										
FUND 0010 GENERAL FUND							TOTAL:	38,893.13		
=====										

12/29/2022 12:43
1540spri

CITY OF SOUTHAVEN
FY 2023 CLAIMS DOCKET D-010323

P 7
apinvgl

YEAR/PERIOD:	2023/1	TO	2023/4								
ACCOUNT/VENDOR		INVOICE	PO	YEAR/PR	TYP	S	WARRANT	CHECK	DESCRIPTION		
0400				UTILITY FUND							
0400	130700			ACCOUNTS RECEIVABLE							
036619	SUMNERS GENE & THERE	41524	0	2023	3	INV P	81.08	D-010323	200800	RE-ISSUE (UT REFUND	
				ACCOUNT TOTAL			81.08				
				ORG 0400	TOTAL		81.08				
820				UTILITY ADMINISTRATIVE EXPENSE							
820	622100			PROFESSIONAL SERVICES							
004781	FAMILY MEDICAL CLINI	12922	0	2023	3	INV P	240.00	D-010323	200786	PRE-EMPLOYMENT SCRE	
				ACCOUNT TOTAL			240.00				
				ORG 820	TOTAL		240.00				
825				UTILITY MAINTENANCE EXPENSES							
825	611300			MAINTENANCE VEHICLES							
002352	DEPARTMENT OF REVENU	NEG16953-UT	0	2023	3	INV P	12.00	D-010323	201127	TAG & MAIL FEE/2022	
002352	DEPARTMENT OF REVENU	NEG16989-UT	0	2023	3	INV P	12.00	D-010323	201128	TAG & MAIL FEE/2022	
							24.00				
021382	PETTY CASH	12-16-2022	0	2023	3	INV P	20.00	D-010323	200799	PETTY CASH/CITY CLE	
				ACCOUNT TOTAL			44.00				
825	625700			TELEPHONE & POSTAGE							
001095	VERIZON WIRELESS	9921887476	0	2023	3	INV P	2,637.91	D-010323	200801	642151677-00001/DEC	
				ACCOUNT TOTAL			2,637.91				
825	626000			UTILITIES							
000966	ENTERGY	135006937264	0	2023	3	INV A	29.74	D-010323		71532782 - 1433 STA	
000966	ENTERGY	155006865384	0	2023	3	INV A	30.02	D-010323		16852907-1334 GOODM	
000966	ENTERGY	155006865385	0	2023	3	INV A	5,944.33	D-010323		16853459-5850 GETWE	
000966	ENTERGY	160005799454	0	2023	3	INV A	263.01	D-010323		16836702-6854 TCHUL	
000966	ENTERGY	205006564841	0	2023	3	INV A	80.54	D-010323		16835787 - HUDGINS	
000966	ENTERGY	205006564842	0	2023	3	INV A	8,524.85	D-010323		16850588 - 7525 GRE	
000966	ENTERGY	250005426348	0	2023	3	INV A	1,403.04	D-010323		17625948-4446 AIRWA	
000966	ENTERGY	250005426349	0	2023	3	INV A	3,453.57	D-010323		17627084- 170 COLLE	
000966	ENTERGY	300003883706	0	2023	3	INV A	29.30	D-010323		126811512-AIRWAYS B	
000966	ENTERGY	30008449983	0	2023	3	INV A	36.41	D-010323		122548779-5253 SWIN	
000966	ENTERGY	315005298711	0	2023	3	INV A	67.69	D-010323		107599953-2543 JIM	
000966	ENTERGY	315005298819	0	2023	3	INV A	82.33	D-010323		122346919-LEGENDS L	
000966	ENTERGY	315005298851	0	2023	3	INV A	284.12	D-010323		122867856- 4164 HIG	
000966	ENTERGY	315005298852	0	2023	3	INV A	276.51	D-010323		122868045-53 WOODLA	
000966	ENTERGY	330003832192	0	2023	3	INV A	39.85	D-010323		163913981 - SWINNEA	
000966	ENTERGY	335005167454	0	2023	3	INV A	92.06	D-010323		43981182-1903 STARL	
000966	ENTERGY	340003798701	0	2023	3	INV A	45.95	D-010323		18141937 - 8440 GRE	
000966	ENTERGY	350003765393	0	2023	3	INV A	95.94	D-010323		57153132-2768 BLACK	



12/29/2022 12:43
1540spri

|CITY OF SOUTHAVEN
|FY 2023 CLAIMS DOCKET D-010323

|P 8
|apinvgl

YEAR/PERIOD: 2023/1 ACCOUNT/VENDOR	TO 2023/4 INVOICE	PO	YEAR/PR TYP S	WARRANT	CHECK	DESCRIPTION
000966 ENTERGY	350003768791	0	2023 3 INV A	190.51 D-010323		102092335-8182 GETW
000966 ENTERGY	350003769041	0	2023 3 INV A	98.66 D-010323		167538396-8827 GETW
000966 ENTERGY	410002911750	0	2023 3 INV A	155.20 D-010323		173771627-5937 KUYK
000966 ENTERGY	420003019416	0	2023 3 INV A	118.00 D-010323		19338714-TURMAN DR
000966 ENTERGY	420003019644	0	2023 3 INV A	119.62 D-010323		76194174-303 LONG S
000966 ENTERGY	425004354595	0	2023 3 INV A	59.76 D-010323		87490884-2017 STARL
000966 ENTERGY	430003040443	0	2023 3 INV A	63.40 D-010323		60572526-GROVE MEAD
000966 ENTERGY	435004308617	0	2023 3 INV A	107.93 D-010323		85491660-CHANCEY CO
000966 ENTERGY	450003099963	0	2023 3 INV A	141.58 D-010323		18757831-3401 WOODL
000966 ENTERGY	470003092890	0	2023 3 INV A	8.44 D-010323		79240206-4154 DAVIS
000966 ENTERGY	470003095247	0	2023 3 INV A	27.53 D-010323		16851735 - 5795 PEP
000966 ENTERGY	65007358939	0	2023 3 INV A	27.04 D-010323		39758438-5850 GETWE
000966 ENTERGY	85007228459	0	2023 3 INV A	3,540.45 D-010323		76259076-3088 NAIL
				25,437.38		
001145 ATMOS ENERGY	1654-122222	0	2023 3 INV A	22.93 D-010323		4012381654 - 53 WOO
001145 ATMOS ENERGY	5862-121322	0	2023 3 INV A	22.93 D-010323		4024565862 - 8182 G
				45.86		
001167 AT&T MOBILITY	8869-120322	0	2023 3 INV P	790.14 D-010323	201126	820538869 - SCADA L
ACCOUNT TOTAL				26,273.38		
ORG 825 TOTAL				28,955.29		
FUND 0400 UTILITY FUND				TOTAL:		29,276.37



12/29/2022 12:43
1540spri

CITY OF SOUTHAVEN
FY 2023 CLAIMS DOCKET D-010323

P 9
apinvgl

YEAR/PERIOD: 2023/1 TO 2023/4
ACCOUNT/VENDOR INVOICE

PO

YEAR/PR TYP S

WARRANT

CHECK

DESCRIPTION

YEAR/PERIOD: 2023/1 TO 2023/4	ACCOUNT/VENDOR	INVOICE	PO	YEAR/PR TYP S	WARRANT	CHECK	DESCRIPTION
850				MAINTENANCE EXPENSES			
850	622100			PROFESSIONAL SERVICES			
	021382	PETTY CASH	12-16-2022	0 2023 3 INV P	14.00	D-010323	200799 PETTY CASH/CITY CLE
				ACCOUNT TOTAL	14.00		
				ORG 850 TOTAL	14.00		
=====							
	FUND 0450	SANITATION FUND		TOTAL:	14.00		
=====							

** END OF REPORT - Generated by Sonya Pride **



12/29/2022 12:39
1540spri

CITY OF SOUTHAVEN
FY 2023 CLAIMS DOCKET W-010323

P 1
apinvgl

YEAR/PERIOD: 2023/1 TO 2023/4	ACCOUNT/VENDOR	INVOICE	PO	YEAR/PR TYP S	WARRANT	CHECK	DESCRIPTION
0600				PAYROLL FUND			
0600	213101			OVERPAYMENT LIABILITY			
	036444	DEUTSCHE BANK TRUST	12-20-2022	0	2023 3 DIR P	603,366.44	W-010323 57136 1WD PAYROLL (12-22-
					ACCOUNT TOTAL	603,366.44	
0600	214900			DEFERRED COMPENSATION			
	002311	EMPOWER RETIREMENT	1050715777	0	2023 3 DIR P	5,991.72	W-010323 57135 DEC. 16, 2022 PAYRO
					ACCOUNT TOTAL	5,991.72	
0600	215101			CAF-PRETAX MEDICAL			
	022644	CORPORATE PLANNING	12-16-2022	0	2023 3 DIR P	1,387.88	W-010323 57134 DEC. 16, 2022 FSA/F
	022644	CORPORATE PLANNING	12-22-2022	0	2023 3 DIR P	4,665.23	W-010323 57137 DECEMBER 22, 2022 F
						6,053.11	
					ACCOUNT TOTAL	6,053.11	
				ORG 0600	TOTAL	615,411.27	
=====							
	FUND 0600 PAYROLL FUND			TOTAL:		615,411.27	
=====							

** END OF REPORT - Generated by Sonya Pride **



12/29/2022 12:36
1540spri

CITY OF SOUTHAVEN
FY 2023 CLAIMS DOCKET U-010323

P 1
apinvgl

YEAR/PERIOD: 2023/1 TO 2023/4
ACCOUNT/VENDOR INVOICE

ACCOUNT/VENDOR	PO	YEAR/PR	TYP	S	WARRANT	CHECK	DESCRIPTION
UTILITY FUND							
0400							
0400 130700							
012774 ADAMS HOMES 41809	0	2023	3	INV A	110.36	U-010323	
014253 DESOTO MANAGEMENT & 41826	0	2023	3	INV A	98.36	U-010323	
026680 SKY LAKE CONSTRUCTIO 41811	0	2023	3	INV A	76.20	U-010323	
026680 SKY LAKE CONSTRUCTIO 41812	0	2023	3	INV A	81.08	U-010323	
026680 SKY LAKE CONSTRUCTIO 41816	0	2023	3	INV A	71.32	U-010323	
026680 SKY LAKE CONSTRUCTIO 41817	0	2023	3	INV A	81.08	U-010323	
026680 SKY LAKE CONSTRUCTIO 41818	0	2023	3	INV A	110.36	U-010323	
026680 SKY LAKE CONSTRUCTIO 41819	0	2023	3	INV A	110.36	U-010323	
026680 SKY LAKE CONSTRUCTIO 41820	0	2023	3	INV A	71.32	U-010323	
026680 SKY LAKE CONSTRUCTIO 41821	0	2023	3	INV A	76.20	U-010323	
026680 SKY LAKE CONSTRUCTIO 41822	0	2023	3	INV A	81.08	U-010323	
					759.00		
029303 WHEELER EMMETT & JAN 41804	0	2023	3	INV A	22.63	U-010323	
030418 NEMANIS MINDAUGAS 41795	0	2023	3	INV A	98.36	U-010323	
035815 D. R. HORTON 41813	0	2023	3	INV A	121.44	U-010323	
035815 D. R. HORTON 41814	0	2023	3	INV A	110.50	U-010323	
					231.94		
036425 MERIDIAN DEVELOPMENT 41810	0	2023	3	INV A	61.56	U-010323	
036837 MOSLEY STEVE 41796	0	2023	3	INV A	18.44	U-010323	
036838 DICKERSON MARTHA 41797	0	2023	3	INV A	98.36	U-010323	
036839 NAGLE GARY & DEBBIE 41798	0	2023	3	INV A	18.89	U-010323	
036841 CATCHINGS JANET 41800	0	2023	3	INV A	66.84	U-010323	
036842 LATONYA OLIVER 41801	0	2023	3	INV A	98.36	U-010323	
036845 ANDERSON TRISTAN 41805	0	2023	3	INV A	110.36	U-010323	
036846 FRAZIER DANIEL O 41806	0	2023	3	INV A	3.36	U-010323	
036847 KIMMONS LACHANDA 41807	0	2023	3	INV A	110.36	U-010323	
036848 C DEVELOPMENT W 41808	0	2023	3	INV A	85.84	U-010323	
036849 S & D PROPERTY INVES 41815	0	2023	3	INV A	201.02	U-010323	
036850 SO MATTHEW 41823	0	2023	3	INV A	71.72	U-010323	
036851 AO PROPCO 1 41824	0	2023	3	INV A	71.72	U-010323	



12/29/2022 12:36
1540spri

CITY OF SOUTHAVEN
FY 2023 CLAIMS DOCKET U-010323

P 2
apinvgl

YEAR/PERIOD: 2023/1 TO 2023/4 ACCOUNT/VENDOR	INVOICE	PO	YEAR/PR TYP S	WARRANT	CHECK	DESCRIPTION
036852 SHADE ALAN	41825	0	2023 3 INV A	98.36 U-010323		
036853 ELITE UNDERGROUND &	41827	0	2023 3 INV A	721.79 U-010323		
			ACCOUNT TOTAL	3,157.63		
		ORG 0400	TOTAL	3,157.63		
=====			FUND 0400 UTILITY FUND	TOTAL:	3,157.63	
=====						



12/29/2022 12:36
1540spri

CITY OF SOUTHAVEN
FY 2023 CLAIMS DOCKET U-010323

P 3
apinvgl

YEAR/PERIOD: 2023/1 TO 2023/4							
ACCOUNT/VENDOR	INVOICE	PO	YEAR/PR TYP S		WARRANT	CHECK	DESCRIPTION
0450			SANITATION FUND				
0450	130700		ACCOUNTS RECEIVABLE				
036840	SHADBURN JANICE- GAR 41799	0	2023 3 INV A		12.00		U-010323
036843	LAWRASON LAURA - GAR 41802	0	2023 3 INV A		14.40		U-010323
036844	MOORE DAVID-GARBAGE 41803	0	2023 3 INV A		12.00		U-010323
			ACCOUNT TOTAL		38.40		
			ORG 0450 TOTAL		38.40		
=====							
FUND 0450 SANITATION FUND					TOTAL:	38.40	
=====							

** END OF REPORT - Generated by Sonya Pride **

14.

Executive Session

Claims/Litigation involving the City;
Economic Development;
Interdepartmental Personnel with No
Action